



CW MILL EQUIPMENT CO., INC.  
P.O. Box 246 • Sabetha, Kansas 66534  
(785) 284-3454 • FAX (785) 284-3601

## DMK 35 -2 Belts

1992-2001 Dodge 318

1993-99 Dodge 360 WO A.I.R. Pump

W-WO/AC

### INSTALLATION NOTES

1. Disconnect battery terminal. Remove fan, fan shroud and serpentine belt. Remove coil and 3 bolts at location "A,B, & C". Remove the six bolts on the crankshaft pulley. Remove center bolt and washer on balancer.
2. Install pulley pilot (2a) into balancer using bolt and lockwasher provided. Torque bolt (2b) to 135lb/ft. Install drive pulley (1) and spacer (2) with new bolts and lockwashers provided.  
**CAUTION:** Be sure new bolts are same thread as O.E.M. bolts.
3. Install pump bracket using bolts (10,11 & 12) with lockwashers on front of bracket and two bolts (8) with lockwashers on back of bracket. Be sure all bolts have been started before tightening any of them.
4. Install serpentine belt, new fan spacer (5), fan and fan shroud. Mount clutch pump (17) to plate (7) and align clutch pulley with drive pulley; tighten securely. Install pump drive belts and adjust to proper tension. Re-mount the coil on back side of bracket (6) with bolts (8) nuts and lockwashers. **CAUTION:** Heater hose may need to be re-routed to prevent pump pulley from damaging it.
5. **CAUTION:** Check all engine compartment hoses and electrical wiring that may have been disturbed or re-routed during kit installation to be sure that hoses are not kinked, that they do not touch any high temperature items, and that they do not interfere with any linkage components.

**NOTE:** This kit is designed to operate successfully with the standard fan supplied by Dodge. Due to O.E.M. assembly tolerances, visually make certain that there is adequate clearance between fan and drive pulley, and also fan to radiator. It may be necessary to use a longer spacer for pulley clearance. If there is little clearance to the radiator, check with Dodge dealer to insure that it will not flex into the radiator before operating. It is not uncommon for the fan to flex over 3/4 inch under full acceleration. Provide adequate clearance between fan and radiator before operating. Move radiator forward if necessary.

## DMK 35 -2 Belts

1992-2001 Dodge 318

1993-99 Dodge 360 WO A.I.R. Pump

W-WO/AC

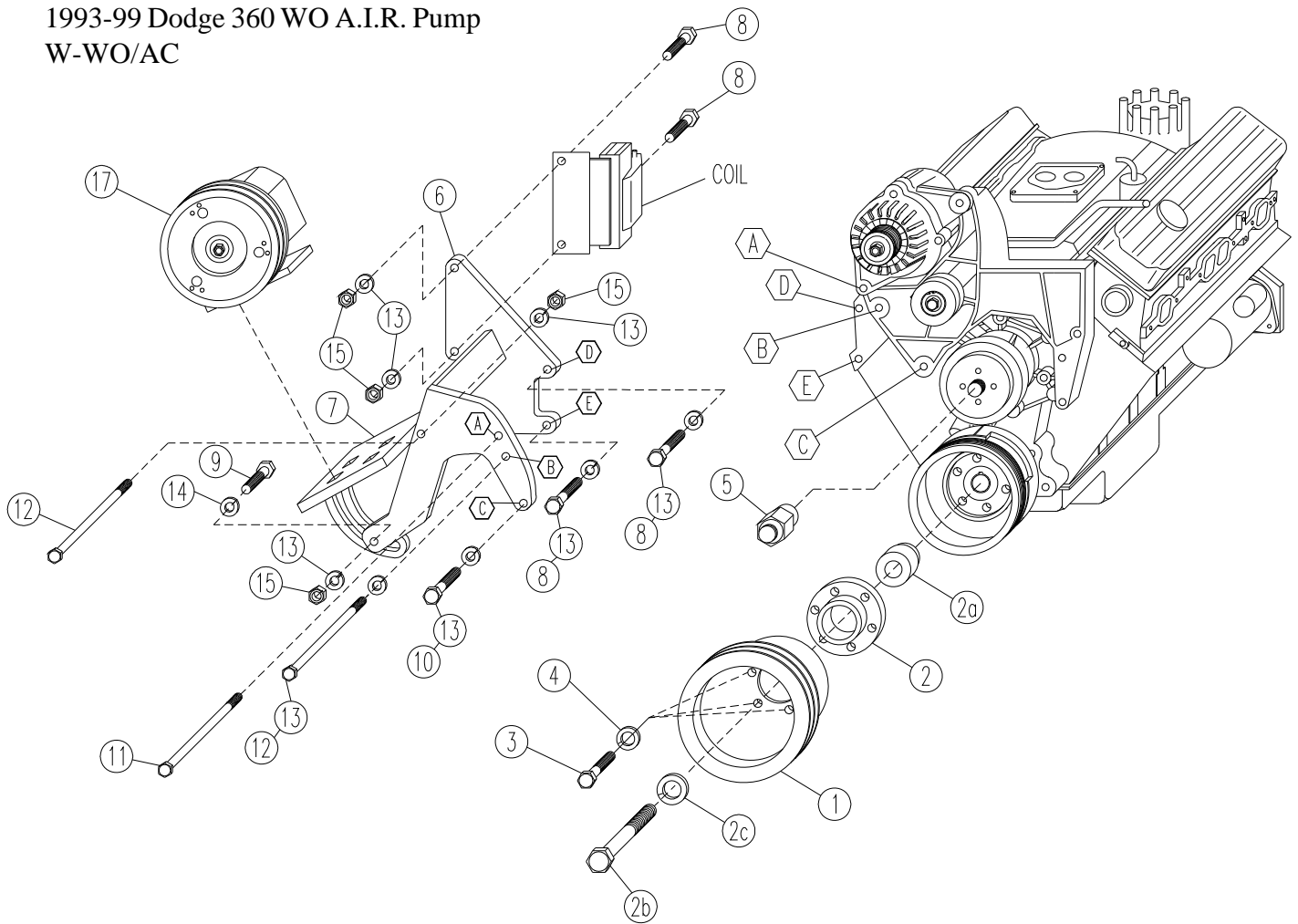

### PARTS LIST

- |                              |   |
|------------------------------|---|
| 1. DPC 352 (1)               | 8. 3/8 X 1 1/4 NC (4)                     |
| 2. DPA 355 (1)               | 9. 3/8 X 1 1/2 NC (1)                     |
| 2a. DPA 356 (1)              | 10. 3/8 X 2 1/4 NC (1)                    |
| 2b. 3/4 X 3 1/2 NF (1)       | 11. 3/8 X 4 1/2 NC (1)                    |
| 2c. 3/4 LW (1)               | 12. 3/8 X 5 NC (2)                        |
| 3. 5/16 X 1 3/4 NC GR. 8 (6) | 13. 3/8 LW (8)                            |
| 4. 5/16 LW (6)               | 14. 3/8 FW (1)                            |
| 5. FSK 30R (1)               | 15. 3/8 NC (4)                            |
| 6. DMB 350 (1)               | 16. A58F (2) (Not Shown)(#2 A57F,#4 A56F) |
| 7. DMP 35(0-4) (1)           | 17. Clutch Pump Assembly (1)              |
|                              | (Sold Separately)                         |

**NOTE:** With 7" Clutch #2 A59F, #4 A56F.