



CW MILL EQUIPMENT CO., INC.  
P.O. Box 246 • Sabetha, Kansas 66534  
(785) 284-3454 • FAX (785) 284-3601

## DMK 38 -2 Belts

2000-02 Dodge 360

W-WO/AC

W/A.I.R. Pump

(Serpentine)

### INSTALLATION NOTES

---

1. Disconnect battery cable. Remove fan, fan shroud and serpentine belt. Remove center bolt and washer on balancer. Remove balancer with proper balancer puller.
2. Remove the bolt holding the damper onto the crankshaft. Using a small 3-Jaw puller, pull the damper off the crankshaft.  
**IMPORTANT:** The jaws on the puller should be placed on the inner hub of the pulley. **DO NOT** pull the damper with the jaws placed on the serpentine pulley. Before installing the new damper, place a small amount of RTV sealer around the keyway of the crankshaft. Install the new damper using the OEM damper bolt and flatwasher. Remove the bolt and flatwasher. Install the V-groove pulley (1) using the three 3/8" bolts and lockwashers (3 & 4). Install 3/4" bolt and lockwasher (2a,b,c) into the crankshaft. Torque bolt to 135 lb/ft..
3. Remove belt tensioner from the A.I.R. pump bracket. Disconnect coil wires and remove the A.I.R. pump and bracket. Remove the A.I. R. pump from the O.E.M. bracket and install it in the new bracket using the two 3/8 X 5 1/2" bolts provided in the kit. Bolt the new bracket (6) in the same place the O.E.M. bracket re-using the three O.E.M. bolts. (Tighten.) Install the serpentine belt tensioner. Using spacers provided in the kit, align the A.I.R. pump pulley with the belt tensioner and the other pulleys. Install serpentine belt. Remove coil from O.E.M. bracket and install it on the new bracket (6) using bolts (11) washers (12) and nuts (13), reconnect coil wires.  
**NOTE:** Do not tighten the two A.I.R. pump bolts until the clutch pump has been installed and belts tightened.

## DMK 38 -2 Belts

2000-02 Dodge 360

W-WO/AC

W/A.I.R. Pump

(Serpentine)

**NOTE:** Remove aluminum smog pump bracket and replace with steel bracket. Use shims to space A.I.R. pump accordingly.

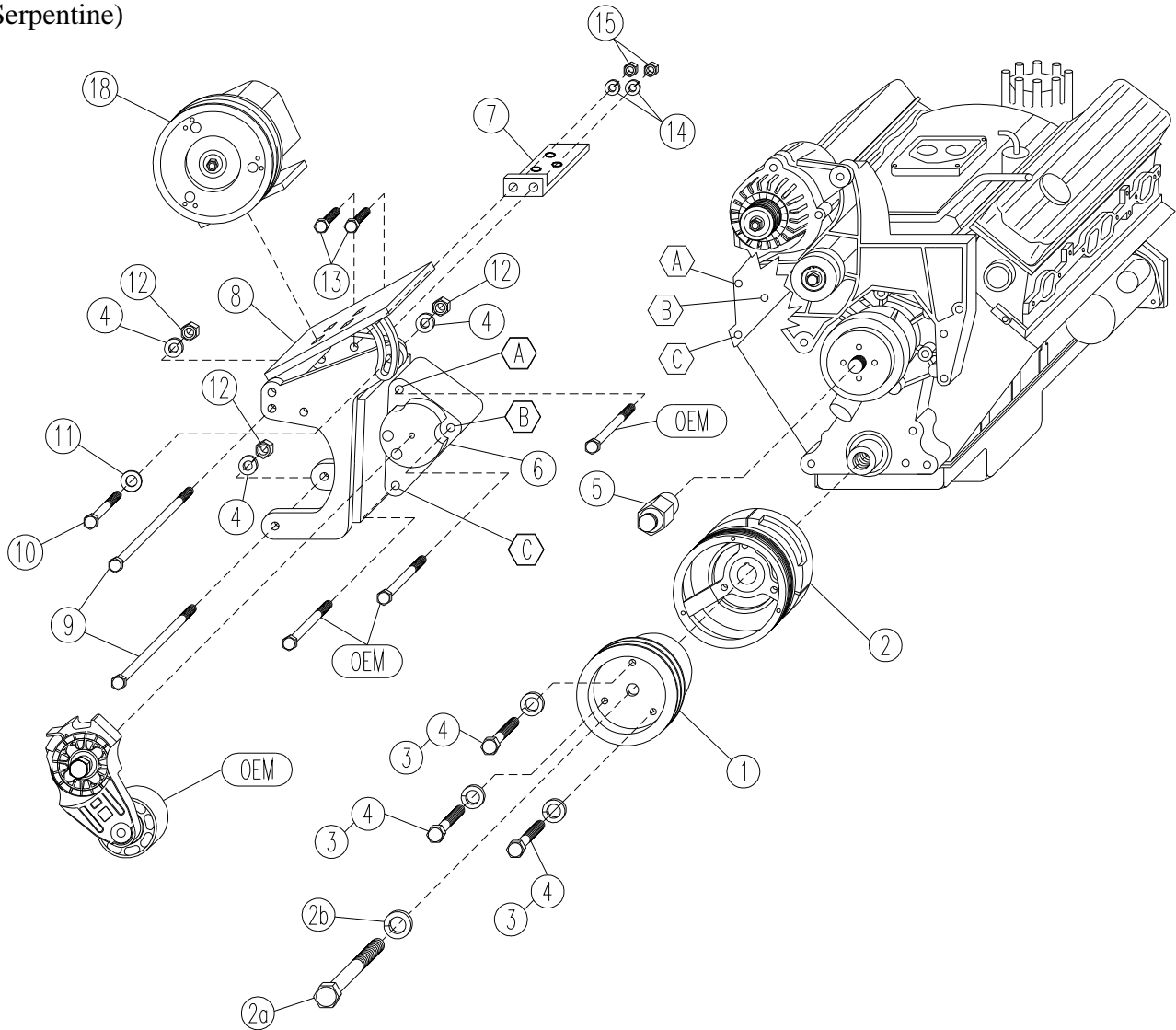

### PARTS LIST

- |                             |                        |   |
|-----------------------------|------------------------|---|
| 1. DPC 382 (1)              | 6. DMB 361 (1)         | 13. 5/16 x 1 NC (5)                                     |
| 2. DDP 382 (1)              | 7. DMB 362 (1)         | 14. 5/16 LW (5)   |
| 2a. 3/4 X 3 NF (1)          | 8. DMP 36(0-4) (1)     | 15. 5/16 NC (5)   |
| 2b. 3/4 LW (1)              | 9. 3/8 x 5 1/2 NC (2)  | 16. Assorted Spacers (Not Shown)                        |
| 3. 3/8 X 1 1/2 NC GR. 8 (3) | 10. 3/8 x 1 1/4 NC (1) | 17. A61F Goodyear (2) (Not Shown)<br>(#2 A60F, #4 A59F) |
| 4. 3/8 LW (6)               | 11. 3/8 FW (1)         | 18. Clutch Pump (Sold Separately)                       |
| 5. FSK 36R (1)              | 12. 3/8 NC (3)         |   |

**NOTE:** With 7" clutch #2 A61F, #4 A60F.