



CW MILL EQUIPMENT CO., INC.
P.O. Box 246 • Sabetha, Kansas 66534
(785) 284-3454 • FAX (785) 284-3601

DMK 39-I8
2003-08 Dodge Ram 2500-3500
5.7 Hemi
W/AC W/O EGR Valve

INSTALLATION NOTES

1. Disconnect the negative battery cable. 08 models do not require coolant draining, fan shroud removal, or radiator overflow tank relocation. Drain the engine coolant until the overflow reservoir is empty. Disconnect the hose from the overflow tank and remove the tank from the fan shroud. Disconnect the wire from the windshield washer tank, remove the tank and lay it aside. Remove the fan (*fan nut has right hand threads*) and fan shroud from the engine compartment.
2. Remove the serpentine belt. Remove the stamped steel brace from between the alternator and A/C compressor and the double ended stud just above the brace. Remove the two alternator bolts and rotate the alternator counter clockwise 90° and install the alternator to the inside alternator mounting spool with the OEM double ended alternator bolt. Torque bolt to 35ft/lbs. On 08 models, it may be necessary to trim a plastic pin from the intake for alternator clearance.
3. Remove the ground strap from the front of the passenger side cylinder head and relocate it. Install bracket (1) onto the engine with bolts (2) with lockwashers (3) at locations "A" & "C", and bolt (4) with lockwasher (5) at location "B". Use shim (1a) when there is no cover at location "B", usually on '03 models. Torque bolts (2) to 35-40ft/lbs., and bolt (4) to 25ft/lbs..
4. Install the idler mounting bracket (8) onto the three studs at locations "D", "E" & "F" with the three OEM flange nuts, torque to 25ft/lbs. Install alternator brace (12) with the long spool end into the alternator with the OEM bolt and the short spool end to the slotted hole on the back side of brace (8) with bolt (6), lockwasher (3) and flatwasher (7), torque bolts to 35 ft/lbs..
5. Install the pump onto the bracket with the bolts provided in the kit. Align the clutch with the existing pulleys and tighten the pump bolts securely.
NOTE: The pump clutch is 8 groove and the belt is 7 groove. The clutch can be aligned to run either the belt on the front 7 or rear 7 grooves.
6. Install the serpentine belt according to the belt diagram without idler (10) installed. With the belt in place, load the belt tensioner and install idler (10) with bolt (11), and bushing (9) into the lowest possible adjustment hole on bracket (8). Tighten the idler bolt and release the tensioner.
- 7a. 08 models reconnect the battery cable.
- 7b. Replace the fan and fan shroud. Replace the windshield washer tank and reconnect the wire. Install the three radiator over flow tank spacers (21) onto the fan shroud with bolts (22) according to the diagram. Install the overflow tank with O.E.M. bolts (13) and flatwashers (14). **NOTE:** The tabs on the bottom of the tank will need to be trimmed in order to allow the tank to be moved over. Install the 1" hose from the kit onto the tank and connect it with the hose barb. The hose may need to be shortened. Replace the engine coolant and connect the battery.

DMK 39-I8 Belt

2003-08 Dodge Ram 2500-3500

5.7L Hemi

W/AC W/O EGR Valve

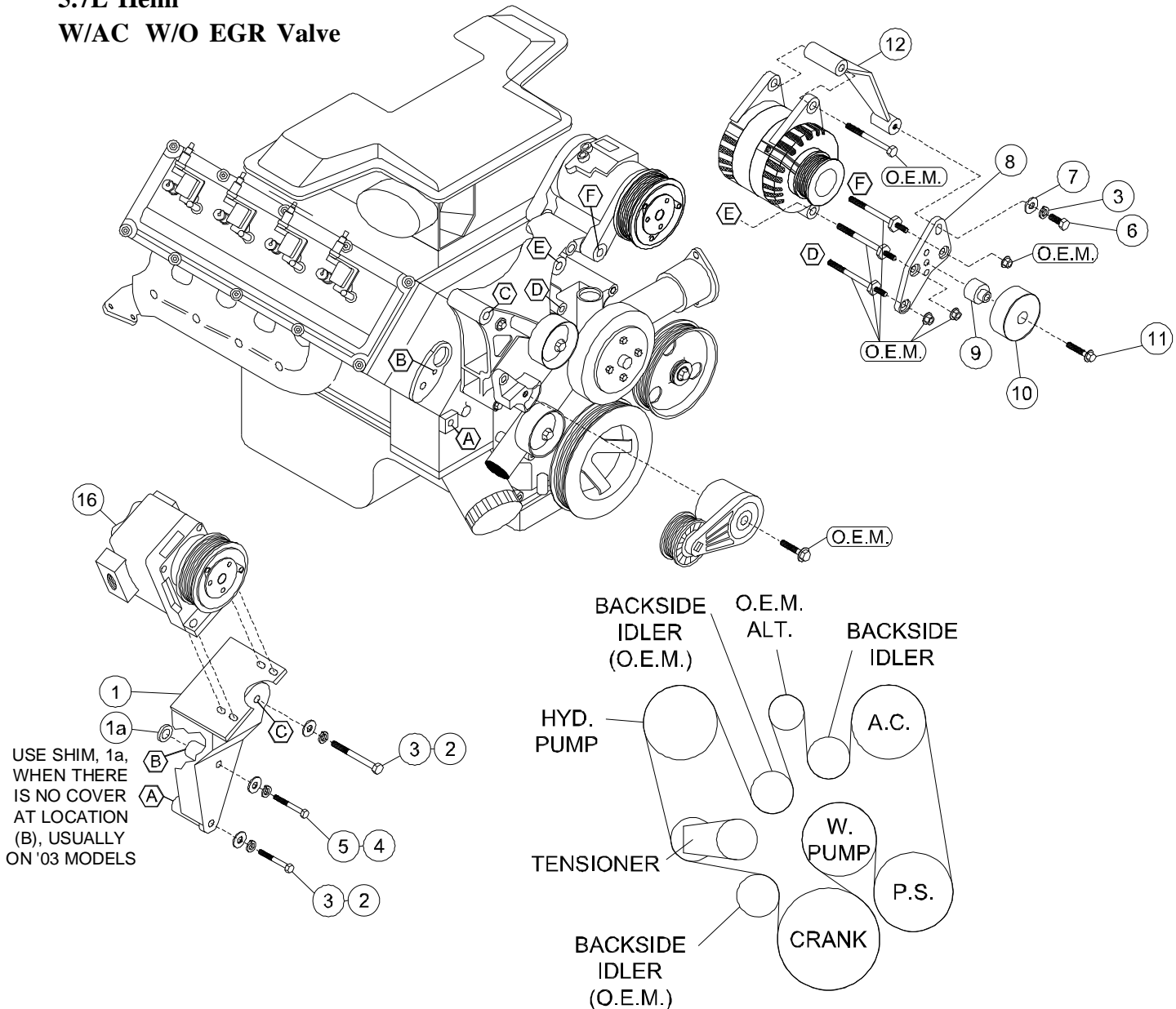

BELT ROUTING

PARTS LIST

- | | |
|---------------------|---|
| 1. DMP 39(0-4) (1) | 11. 10mm x 50mm Flange (1) |
| 1a. SP88-.170 Shim | 12. DMB 391 (1) |
| 2. 10mm x 90mm (2) | 13. 1" Hose Barb (1) |
| 3. 10mm LW (3) | 14. 12" of 1" Hose (1) |
| 4. 8mm x 75mm (1) | 15. Hose Clamps (2) |
| 5. 8mm LW (1) | 16. Clutch Pump Assembly (1)
(Sold Separately) |
| 6. 10mm x 30mm (1) | 17. DMB 393 (3) |
| 7. 10mm FW (1) | 18. 6mm x 20mm (3) |
| 8. DMB 390 (1) | 19. 5071190 Belt (1) |
| 9. DMB 392 (1) | |
| 10. 89016 Dayco (1) | |

DMK 39-I8 DMK 39A-I8

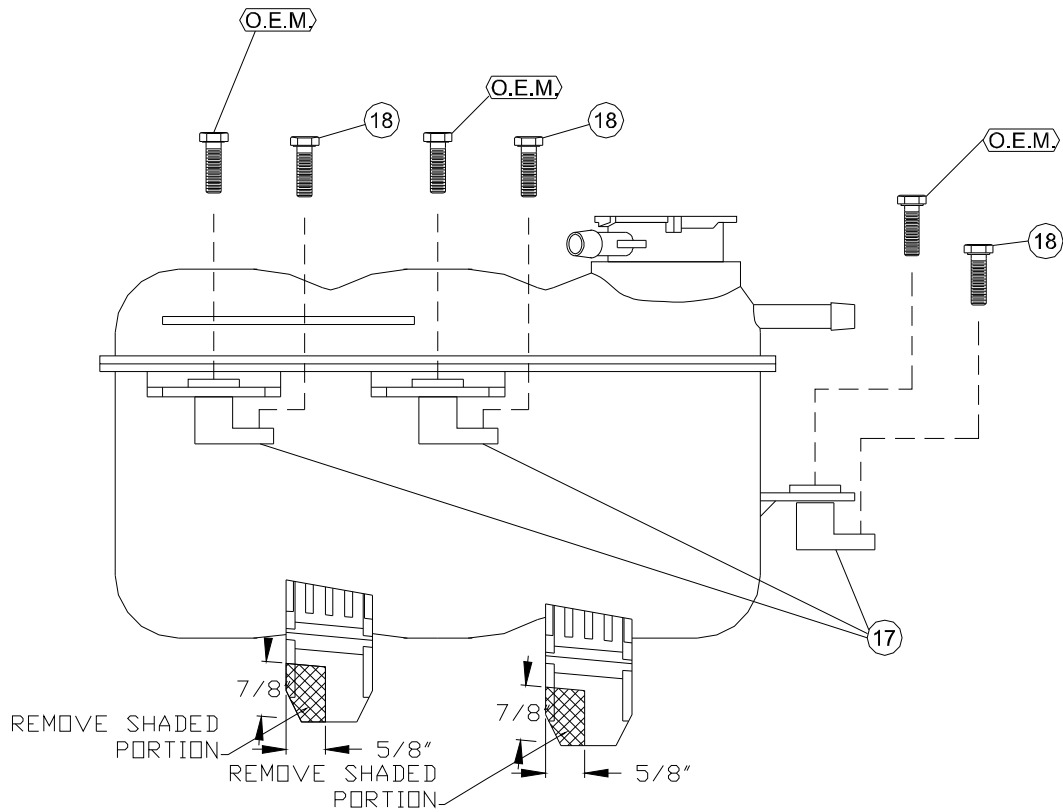

VIEW FROM FRONT

WATER TANK MODIFICATION