



CW MILL EQUIPMENT CO., INC.
P.O. Box 246 • Sabetha, Kansas 66534
(785) 284-3454 • FAX (785) 284-3601

DMK 61 -1 Belt
1994-03 Dodge Truck V-10
W-WO/AC

INSTALLATION NOTES

1. Disconnect battery(s). Remove fan and fan shroud. The transmission coolant line may need to be disconnected to make enough room to get the fan shroud out. Remove serpentine belt. Remove large center bolt from the drive pulley and with a small 3-jaw puller, remove drive pulley from the crankshaft.
2. Using the pulley provided in the kit as a drill guide, drill four 5/16 holes in the O.E.M. pulley. When drilling the pulley make sure it is piloted onto the O.E.M. pulley and clamped down securely. Once the first hole is drilled, put a 5/16 bolt in that hole to keep the two pulleys from moving. After all four holes are drilled, tap the holes with a 3/8 X 16 tap. You may use the four 13/32 holes to help guide the tap in straight. Bolt the two pulley's together using the bolts provided in the kit. Install pulley back onto the crankshaft and tighten bolt to 135 ft./lb. of torque. **IMPORTANT:** Re-torque pulley bolt after 2 weeks or 500 miles.
3. Remove bolts at locations "A, B,C & D". Install idler (IPKD-61) onto bracket (5). Install bracket (5) at location "E" with bolt (8) that has extra threads. Thread bolt (8) through upper A.I.R. aluminium bracket and tighten bracket (5) with washer (13) and nut (14). Install bracket (5) at locations "B" and "C" with bolts and washers (9,13) and at location "D" with bolt and washer (10 & 13). Tighten bolts at all locations.
4. Install fan spacer (4) onto the fan and replace fan & fan shroud back onto the truck. **NOTE:** The fan shroud may need to be trimmed to provide enough room for the fan.
5. Install pump plate (6) with bolts (7 & 11) to bracket (5). Mount clutch pump (23) onto pump plate (6) with pump bolts provided. Make sure clutch is aligned with drive pulley (1). Align idler with both clutch pump pulley and drive pulley (1). Install serpentine belt and pump drive belt (22), adjust pump plate (6) for proper belt tension, tighten bolts (7 & 11).
6. Connect battery(s) and any hoses that were disconnected during installation. Check for leaks and clearances on belts and hoses.

DMK 61 -1 Belt
 1994-03 Dodge V-10
 W-WO/AC

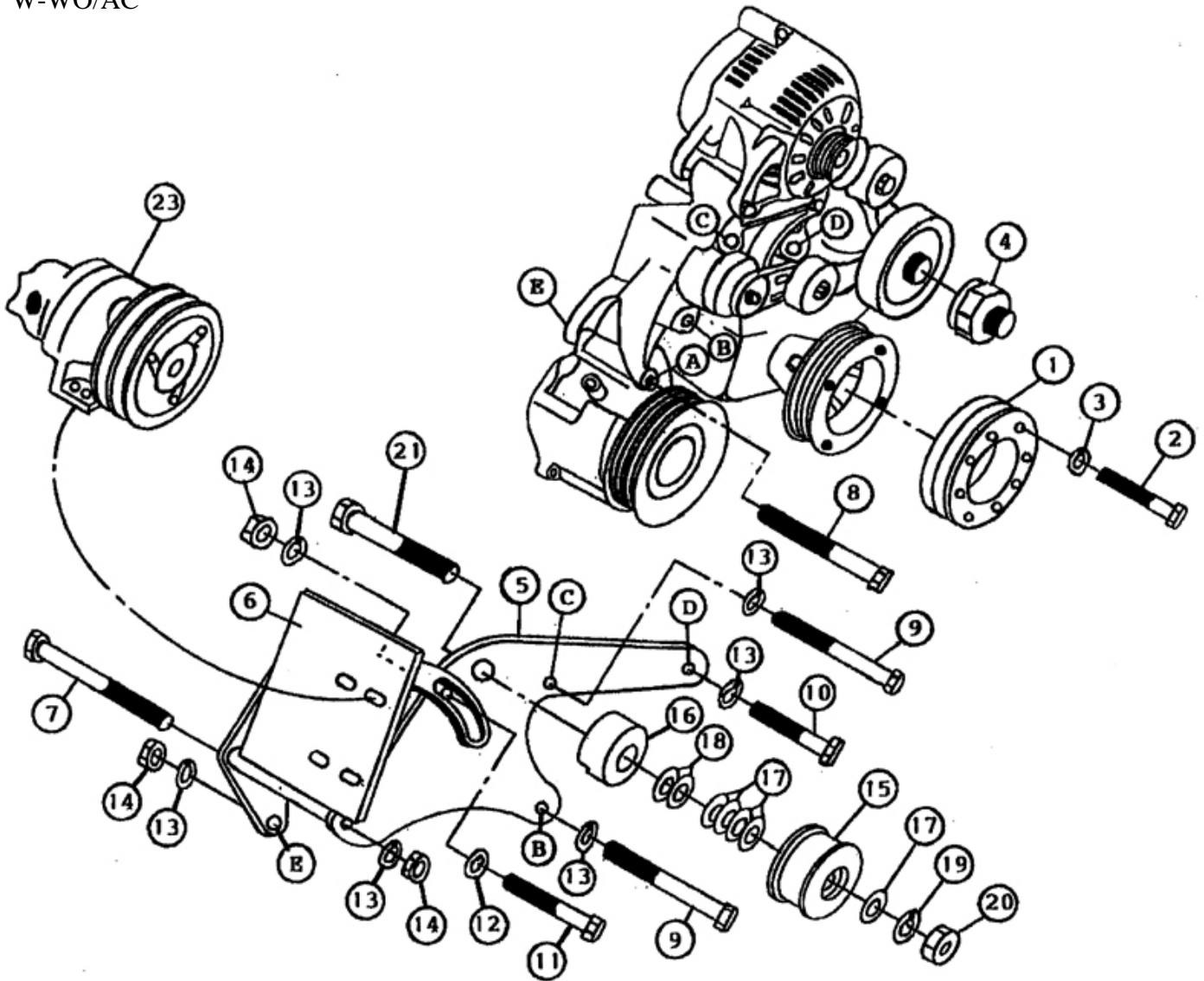

PARTS LIST

- | | |
|--------------------------|---|
| 1. DPC 611 (1) | 13. 3/8 LW (6) |
| 2. 3/8 X 2 NC Gr. 8 (4) | 14. 3/8 NC (3) |
| 3. 3/8 LW (4) | <u>IPKDD-61 Assembly includes items 15-21:</u> |
| 4. FSK 37R (1) | 15. IPCD (1) |
| 5. DMB 610 (1) | 16. SP175-1.250 (1) |
| 6. DMP 61(0-4) (1) | 17. IPW14 (5) |
| 7. 3/8 X 6 NC (1) | 18. 5/8 FW (2) |
| 8. 3/8 X 5 1/2 NC SP (1) | 19. 5/8 LW (1) |
| 9. 3/8 X 5 1/2 NC (2) | 20. 5/8 NC (1) |
| 10. 3/8 X 2 3/4 NC (1) | 21. 5/8 X 4 NC (1) |
| 11. 3/8 X 1 1/2 NC (1) | 22. A63K (1) (Not Shown) |
| 12. 3/8 FW (1) | (#2 A62F,#4 A61F) |
| | 23. Clutch Pump Assembly |
| | (Sold Separately) |

NOTE: With 7" clutch #2 A63F, #4 A62F.