



CW MILL EQUIPMENT CO., INC.
P.O. Box 246 • Sabetha, Kansas 66534
(785) 284-3454 • FAX (785) 284-3601

FCFK45A-I8
2005-07 Ford LCF
International CF
VT275 W/AC

INSTALLATION NOTES

1. Disconnect the negative battery cables. Remove the OEM belt. Remove the OEM belt tensioner. Drain engine coolant. Remove heater hose line from water pump. Install new heater hose line (26) reusing oem hardware. Reconnect heater hose using nipple (27), hose (28), and hose clamps (29).
2. Install bracket (1) onto the engine with bolts (2) and lockwashers (3) at locations A, B, C, and D. Torque bolts to 40 ft. lbs. Remove the two alternator bolts at locations E and F. Install brace (4) with bolts (5), lockwasher (3), and flatwasher (7) at locations E and F; and bolt (6) with lockwasher (3) and flatwasher (7) at location G. Tighten all three bolts finger tight, then torque them to 35 ft. lbs.
3. Remove the grooved idler from the O.E.M. tensioner and replace it with idler (8), reusing the O.E.M. hardware. Torque the bolt to 30 ft. lbs. Install idler (9) with bolt (10), FW (11), and bushing (12) location "H". Torque bolt to 35 ft. lbs. Install pump (13) onto bracket (1) using bolts (14) with lockwashers (15), FW's (17) and nuts (16). Torque nuts to 35 ft. lbs. Install the coil and clutch per manufactures instructions. Install the tensioner back to its original location. Install the new belt (25) and route it according to the belt diagram.
Note: The steel tab on the tensioner may need to be bent out of the way for belt clearance.
4. Loosen all 4 bolts on drivers side of turbo and swing turbo outlet down for new tube to line up and clear the cab when in locked position. Install tube (22) with coupler (20) and clamps (23) on turbo end and coupler (21) and clamps (24) on intercooler end. Tighten turbo bolts. Connect the battery cables. Run the engine and check for proper belt tracking and clearances.

FCFK45A-I8

05-07 Ford LCF

International CF

VT275 W/AC

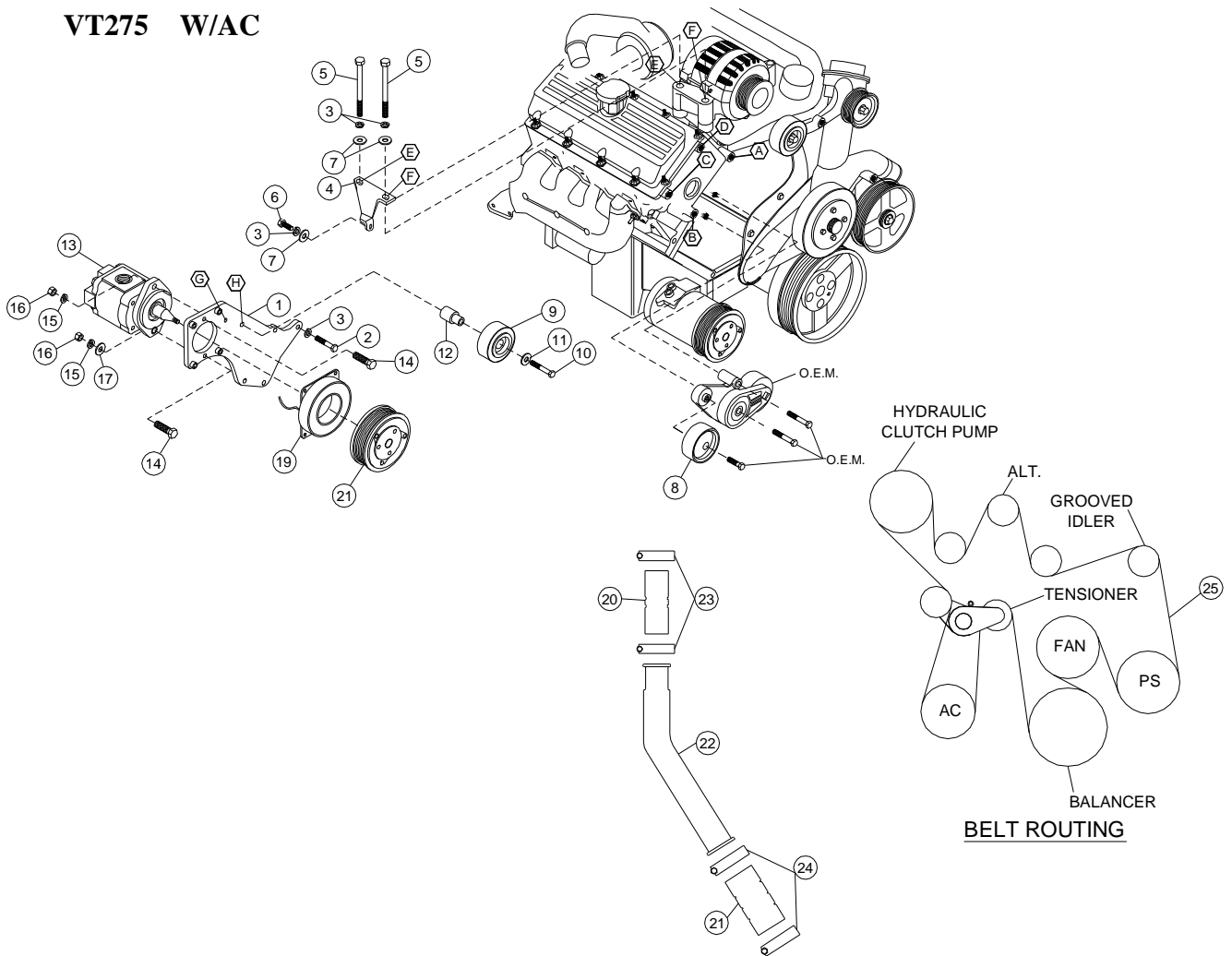

PARTS LIST

- | | | |
|-------------------------------|---|--|
| 1. FCFMP45A-I8(1) | 12. FCFMB 452 (1) | 21. TCA 253 |
| 2. 10mm x 45mm 1.50, 10.9 (4) | 13. Clutch Pump Assembly
(Sold Separately) | 22. ST 2.5-32-2 Steel Tube(1) |
| 3. 10mm LW (7) | 14. 3/8 x 1 1/2 NC (2) | 23. 250-67 Hose Clamp(1) |
| 4. FCFMB 451 (1) | 15. 3/8 LW (2) | 24. 250-73 Hose Clamp(1) |
| 5. 10mm x 90mm 1.50, 10.9(2) | 16. 3/8 Nut NC (2) | 25. K8 x 149.0 Dayco (Main Drive Belt) |
| 6. 10mm x 20mm 1.50 10.9 (1) | 17. 3/8 FW (1) | 26. CFMB453 (1) (NOT SHOWN) |
| 7. 10mm FW (3) | 18. Coil (Sold Separately) | 27. 3/4" Nipple (1) |
| 8. 89016 Idler Dayco (1) | 19. Clutch (Sold Separately). | 28. 3/4" x 12" Heater Hose (1) |
| 9. TIPCS Idler(1) | 20. TCA 202 (2" Rubber
Coupler) (1) | 29. 3/4" Hose Clamp(2) |
| 10. 12mm x 65mm 1.75 10.9 (1) | | |
| 11. 12mm FW (1) | | |