



CW MILL EQUIPMENT CO., INC.
P.O. BOX 246 • Sabetha, Kansas 66534
(785) 284-3454 • FAX (785) 284-3601

FLMK61A-I8AC
2002-08 Freightliner
M2 Business Class
Sterling Actura 2005-08
MBE900 Mercedes-Benz 6 cyl
4-bolt Alternator
W/AC

INSTALLATION NOTES

1. Disconnect the negative battery cable(s). Remove the accessory drive belt and the alternator.
2. Install bracket (1) with bolts (2) and lockwashers (3) onto the alternator bracket. **Note:** If installing on 2005 and later truck, the O.E.M. alternator may need trimmed for clearance. Also, the vent tube may need reformed for alternator clearance. Torque bolts to 40 ft. lbs. Install the alternator and alternator brace onto bracket (1) with the O.E.M. alternator bolts thru the alternator, and bolt (5) with lockwasher (3) at location (A). Tighten bolts finger tight, then torque them to 35 ft. lbs.
3. Install the pump (13) onto bracket (1) with bolts (9), flatwashers (10), lockwashers (11), and nuts (12). Torque to 35 ft. lbs. Install the coil and clutch as per manufacture's instructions. Install idler (6) with bushing (7), lockwasher (3), and bolt (8). Torque to 30-35 ft. lbs. Install the new belt and route it according to the belt diagram.
4. Check all hoses, wires, etc. that may have been disturbed during installation to make sure they do not come in contact with any hot or moving parts. Connect the battery cable(s). Run the engine and check for proper belt tension and tracking.

FLMK61A-I8AC

2002-08 Freightliner

M2 Business Class

Sterling Actura 2005-08

MBE900 Mercedes-Benz 6 cyl

4-bolt Alternator

W/AC

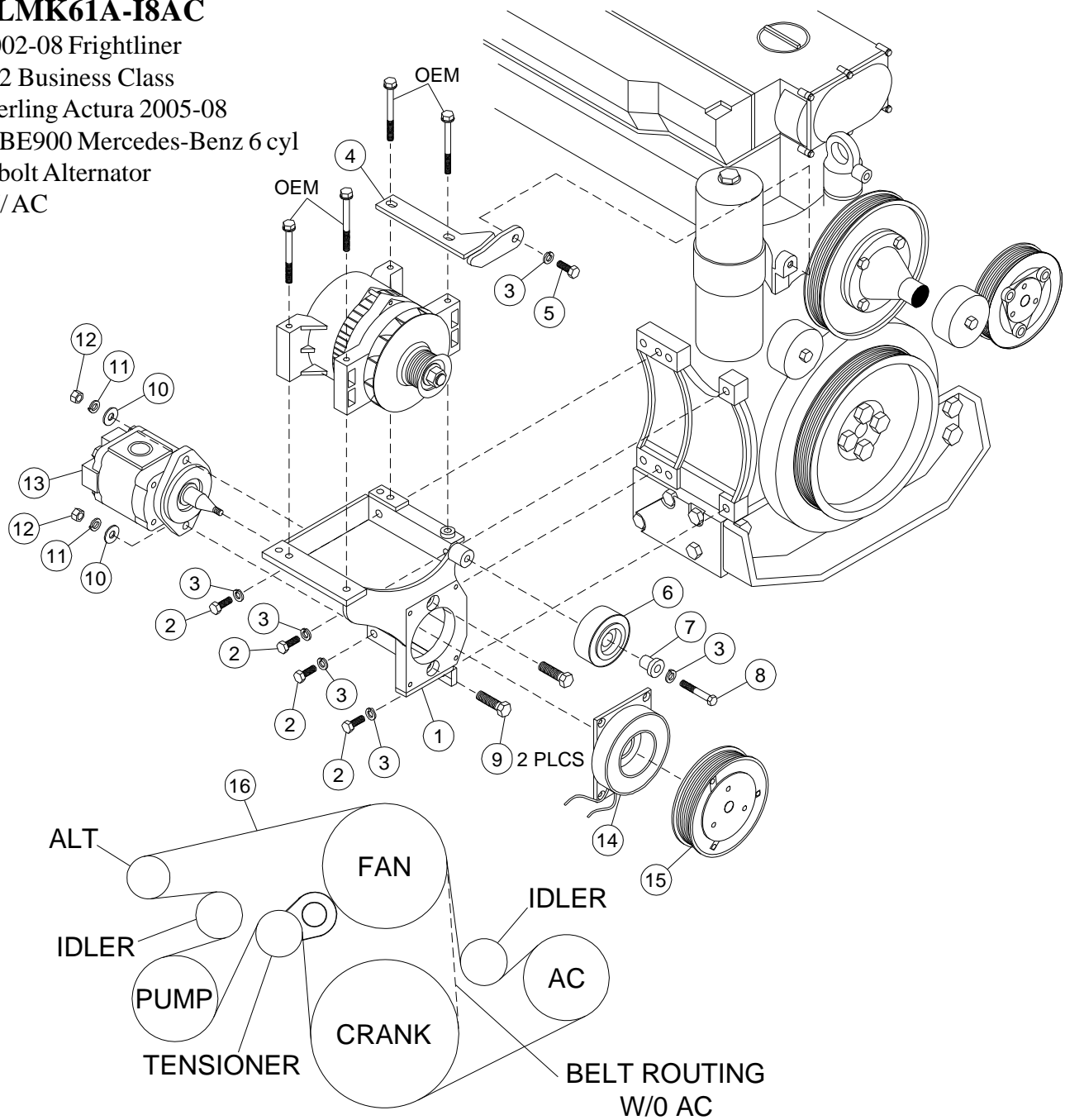

BELT ROUTING

PARTS LIST

- | | |
|---------------------------------------|-----------------------------------|
| 1. FLMP 61A (1) | 9. 3/8 x 1-1/2 Bolt (2) |
| 2. 10mm x 30mm (4) | 10. 3/8 FW (2) |
| 3. 10mm LW (6) | 11. 3/8 LW (2) |
| 4. FLMB 611 (1) | 12. 3/8 NC Nut (2) |
| *FLMB 612 (1) (use on 2005 and later) | 13. Clutch Pump (sold separately) |
| 5. 10mm x 25mm (1) | 14. Coil (sold separately) |
| 6. TIPCS (1) | 15. Clutch (sold separately) |
| 7. IPB 203 (1) | 16. 5081020 Dayco Belt (1) |
| 8. 10mm x 35mm (1) | |