

**Note: Must use side ported pump with 45 deg. fittings.**

## **INSTALLATION NOTES**

---

1. Disconnect batteries. Remove the air cleaner from the passenger side and the charge air tube from the driver's side. Remove the P/S reservoir from the fan shroud and lay aside. It is not necessary to drain any P/S fluid. Remove the top half of the fan shroud. Unplug the fan wire and remove the fan. Fan nut has right hand threads. Remove the top two fan diffuser nuts. Remove the belt and tensioner. Remove the 5 bolts holding the fan hub to the engine and remove it from the engine compartment. Retain the bolts for use in installation.
2. Remove the four bolts from the crank pulley and install the new drive pulley(1) using bolts (2) **On 2016 models trucks make certain the machined cavity in the pulley is aligned with the counter weight on the inside of the damper**. A mild grade of lock-tite is recommended. Install pump onto bracket(3) using bolts(19), flatwashers(20), lockwashers(21) and nuts(22). It might be necessary to have the fittings installed before sliding the bracket against the engine. Remove the split bushings from the OEM bracket and install them into the new bracket. Install the main bracket(3) in place of the fan hub reusing the OEM bolts. Install clutch and coil per manufacturers instructions. Always check pump alignment with drive pulley.
3. Install the OEM tensioner and the OEM belt back onto the engine as shown in illustration on back. Remove the idler from the OEM fan hub and remove the bolt from the idler. Install the O.E.M. idler using bolt(13), lockwasher(8), flatwasher(7) and bushing(10). Install the pump tensioner bracket(4) onto the bracket and engine using bolts(5,6). Install idler(15) with the short bushing(11) to tensioner bracket(4) using bolt(14), lockwasher(8), and flatwasher(7). Install idler(15) with the long bushing(9) onto bracket(3) using bolt(12), lockwasher(8) and flatwasher(7). Install tensioner(16) using bolt(17). Install pump drive belt as shown in illustration on back. Achieving proper belt alignment is the installer's responsibility.
4. Replace the nuts onto the fan diffuser. It may be necessary to trim the diffuser if it hits the clutch. Replace the fan. Tighten the fan nut, then rotate the wire holder up and bolt it to bracket(4) using bolt(18). Replace the fan shroud. Connect the pump hoses. Replace the air cleaner and charge air tube.
5. Make certain no wires come in contact with any moving or hot parts.

# FMK264A-8

2012-2017 F-250-550

6.7L DIESEL

W/WO AC, WO DUAL ALTERNATORS

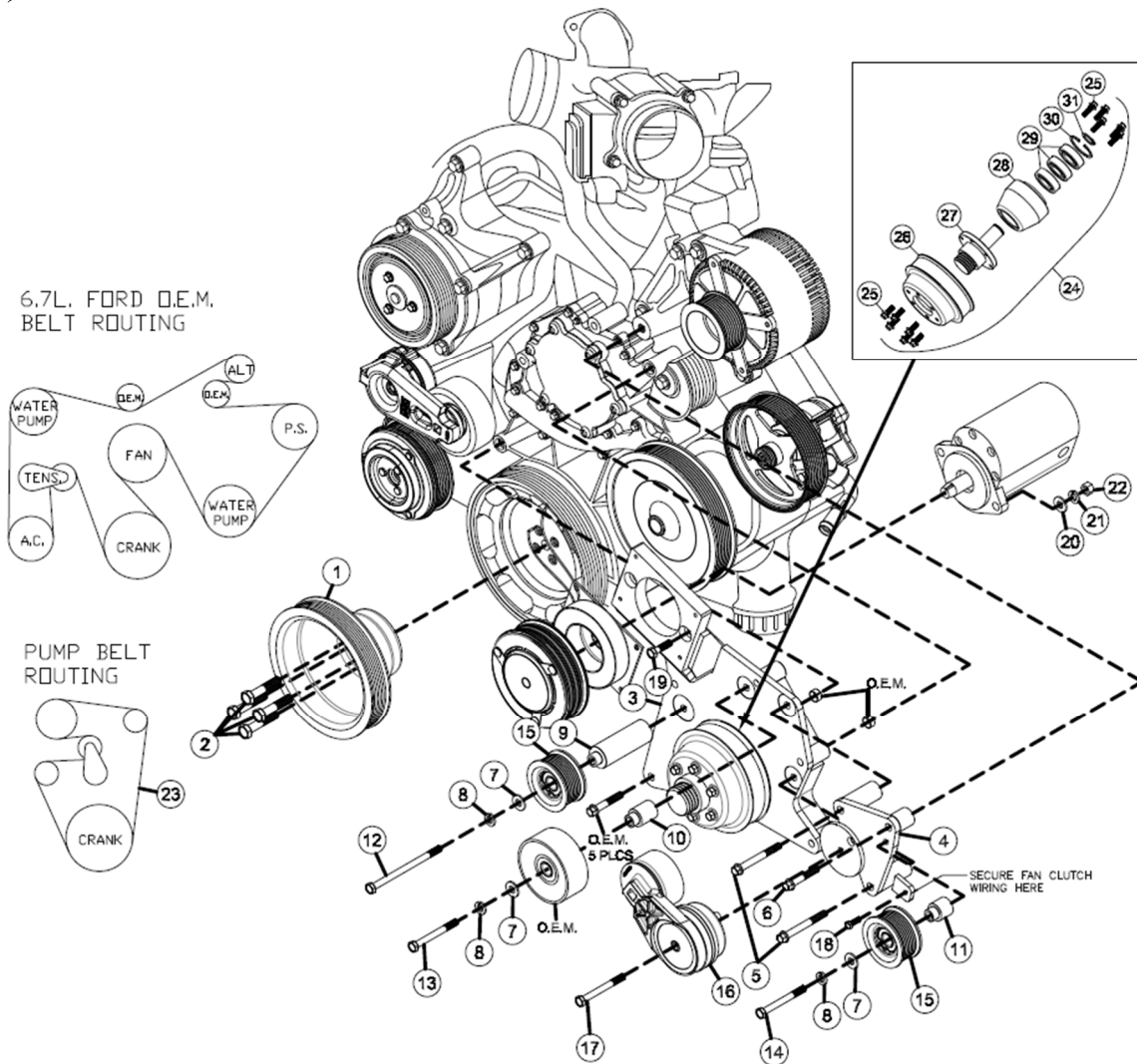

## PARTS LIST

1. FPC2638AL (1)
2. 12mm x 75mm 1.5 (4)
3. FMP264A-8 (1) (Does not include assembly 24)
4. FMB2610 (1)
5. 10mm x 80mm Flange (2)
6. 10mm x 50mm Flange (1)
7. 3/8 Flatwasher (3)
8. 10mm Lockwasher (3)
9. FMB2617 (1)
10. FMB2616 (1)
11. FMB2615 (1)
12. 10mm x 120mm (1)
13. 10mm x 60mm (1)
14. 10mm x 50mm (1)
15. 89053 (2)
16. 89470 Dayco (1)
17. 10mm x 65mm (1)

18. 8mm x 12mm Flange (1)
19. 3/8 x 1-1/2 (2)
20. 3/8 Flatwasher (2)
21. 3/8 Lockwasher (2)
22. 3/8 Nut (2)
23. Dayco 5080700 (1)
24. FSK262 (1)

### ITEM 24 INCLUDES ITEMS 25-31

25. 8mm x 20mm Flange (11)
26. FPC2620 (1)
27. FSO261 (1)
28. FMB2611 (1)
29. MRC205SZZ Bearing (3)
30. HO206ST-PA Snap Ring (1)
31. SH98 Snap Ring (1)

10/11/2016