



**This kit will NOT work on trucks equipped with adaptive steering.**

## **INSTALLATION NOTES**

---

1. Disconnect negative batteries cables. Remove the air duct from the passenger side and the black rubber charge air tube from the driver's side. Remove the plastic cowl from the top side of the radiator.(14 clips total) Remove the P/S reservoir and coolant reservoir from the fan shroud, then remove the bolts and remove the top half of the fan shroud.
2. It is highly recommended the radiator be protected with cardboard or other suitable material. Remove the bolt holding the fan wire standoff to the engine then disconnect the fan wire. Remove the fan. Fan nut has right hand threads. Remove the OEM serpentine belt. Disconnect the wires from the alternator and remove it. Drain as much fluid as possible from the P/S reservoir then remove the return hose connecting the reservoir to the P/S pump. Remove the P/S pump from the bracket and lay it inside the fan shroud. It is not necessary to remove the steel pressure line from the P/S pump. Remove the P/S pump and alternator bracket from the engine.
3. Remove the plastic wire harness support from the engine and battery cables, it will not be reused. The battery cables will need to be separated from the alternator wire and rewrapped using the protective sleeves supplied in the kit. After the battery cables are rewrapped, secure the wires to the engine using the standoff (9) and loom clamp (23) with the front lower valve cover bolt. Use the other loom clamp (23), bolt (16) and nut (17) supplied to secure the battery cables to the radiator reservoir.
4. Install the clutch pump onto the new bracket with bolts (24). Install the bracket assembly onto the engine with bolts (13) at locations A and C, and bolts (14) at locations B and D. Torque bolts to 24-27 ft. lbs. Install the P/S bracket (2) onto the main bracket as shown in the illustration with bolts (15). Remove the suction hose elbow from the P/S pump and install the straight nipple (5) and hold down (6) reusing the OEM bolt. Install hose (19) onto the P/S pump with clamp (22). Install the P/S pump onto bracket (2) reusing the OEM bolts. The steel pressure line will need to be bent slightly in order to install the pump, but does not need to be removed. The steel line will run behind the water pump pulley. Install the alternator with the OEM bolts and connect the wires.
5. Remove the four crank pulley bolts and install the drive pulley with bolts (27). Install bracket (3) onto the main bracket with bolts (15). Remove the grooved idler from the OEM bracket and install it onto the new bracket with OEM bolt just below the alternator. Install idler (7) with bolt (12) and bushing (4) onto the new P/S bracket. Install the OEM belt as shown in the belt diagram. Install the aftermarket belt as shown.
6. Trim the fan ring as shown then install it back onto the engine. (There will only be three mounting locations) Install the all thread into the hole on the fan hub marked fan bolt and slide the black spacer over it. Install the threaded fan spacer (25) and the fan. Place the fan wire standoff over the all thread as the fan is being screwed on. Once the fan has been tightened, secure the fan wire standoff with the 8mm flange nut. Replace the fan shroud and radiator cover. Fit the P/S hose to the P/S reservoir and cut it to length. Secure with hose clamp (22).

**NOTE: It is the installers responsibility to make sure all hoses, wires, etc. and secure and away from any hot or moving parts.**

# FMK265A-8

2017 F-250-550

6.7L DIESEL

With DUAL ALTERNATORS

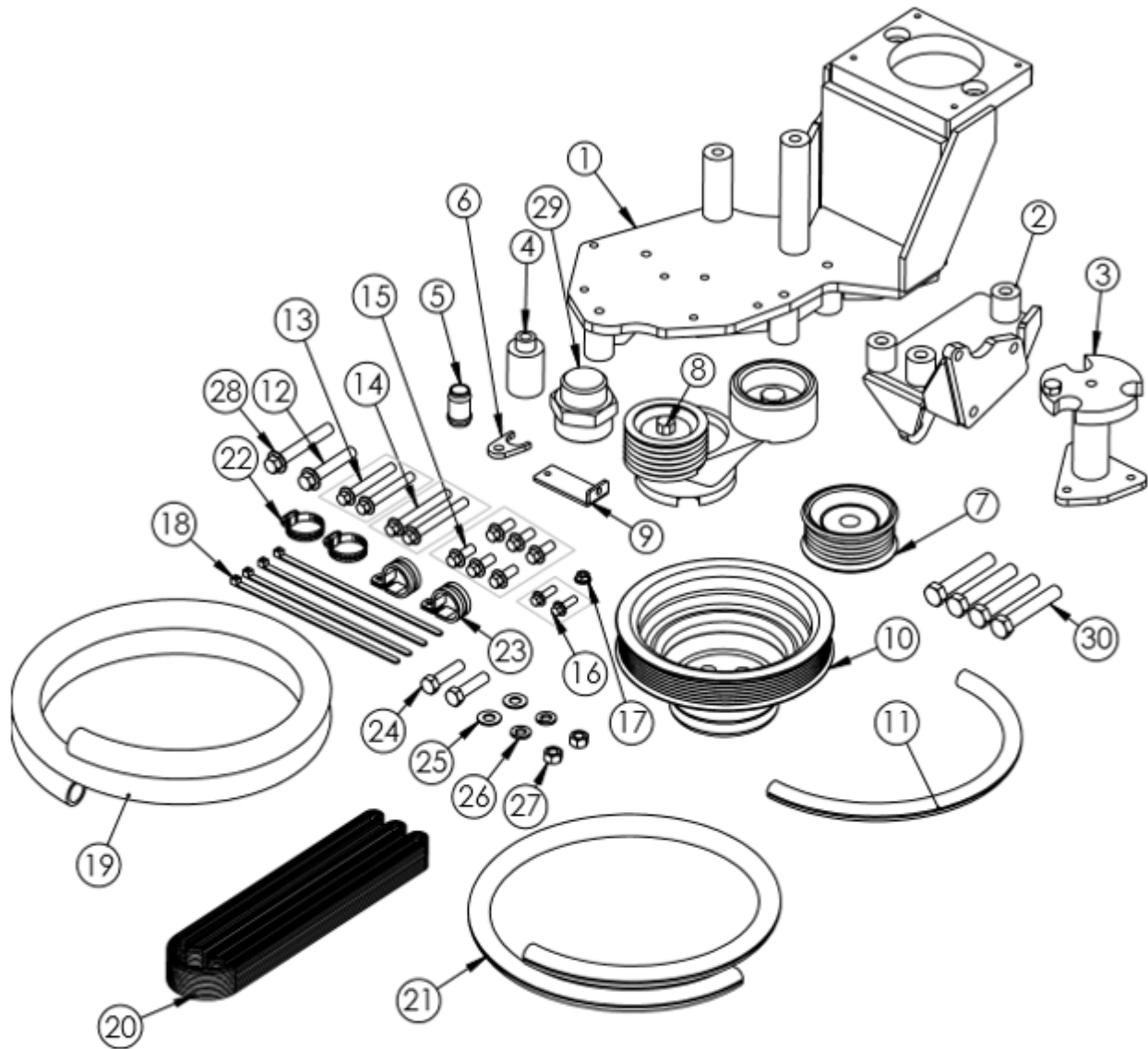

## PARTS LIST

- |                                  |                                  |                        |
|----------------------------------|----------------------------------|------------------------|
| 1. FMB265A (1)                   | 12. 10X55MM (1)                  | 23. #16 ADEL CLAMP (2) |
| 2. FMB265-1 (1)                  | 13. 8X60MM (2)                   | 24. 3/8X1.5 (2)        |
| 3. FMB265-2 (1)                  | 14. 8X70MM (2)                   | 25. 3/8 FW (2)         |
| 4. FMB265-4 (1)                  | 15. 8X20MM (6)                   | 26. 3/8 LW (2)         |
| 5. 4200-12-12 (1)                | 16. 6X20MM (2)                   | 27. 3/8 NUT (2)        |
| 6. BARB CLAMP (1)                | 17. 6MM NUT (1)                  | 28. 10X70MM (1)        |
| 7. 89053 (1)                     | 18. TIE STRAP (4)                | 29. FSK-265 (1)        |
| 8. 89254 (1)                     | 19. 3/4" OIL HOSE (40")          | 30. 10x75MM (4)        |
| 9. FMB265-3 (1)                  | 20. 5080655 BELT (1)             |                        |
| 10. FPC2658 (1)                  | 21. 3/4" HOSE<br>PROTECTOR (36") |                        |
| 11. 5/8" HOSE<br>PROTECTOR (12") | 22. #12 HOSE CLAMP (2)           |                        |

**FMK265A-8**  
2017 F-250-550  
6.7L DIESEL  
With DUAL ALTERNATOR

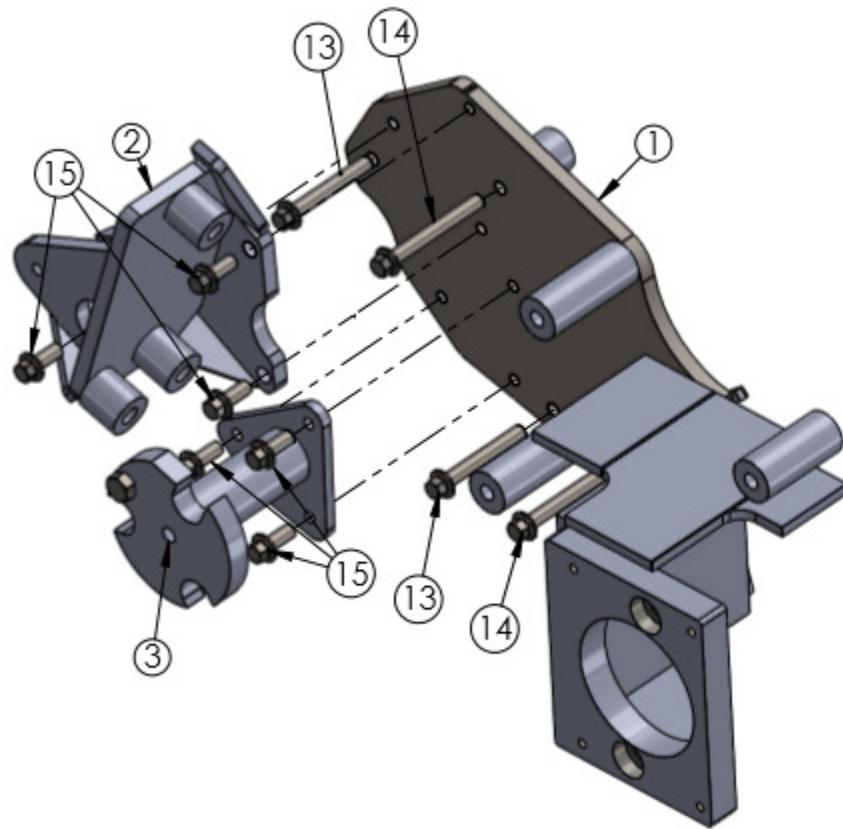
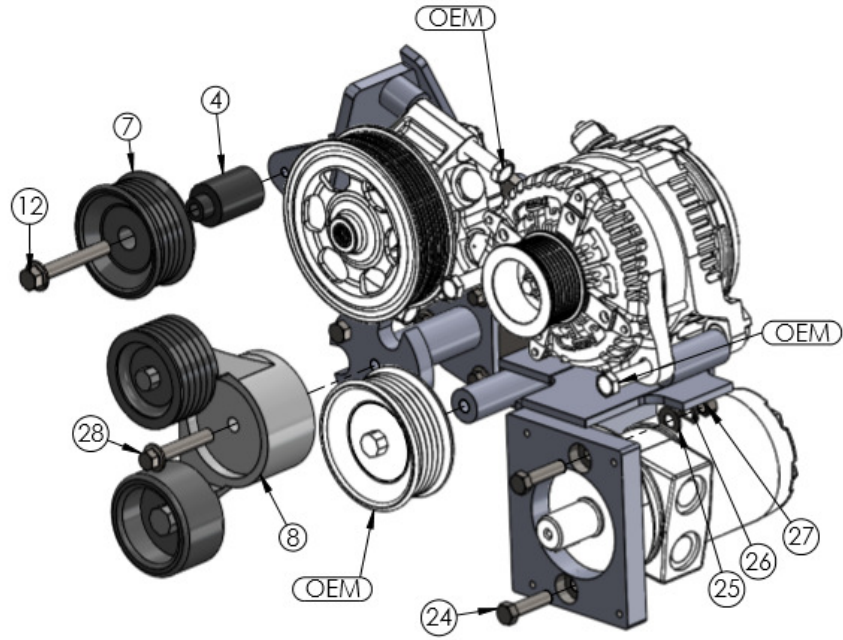

# FMK265A-8

2017 F-250-550

6.7L DIESEL

With DUAL ALTERNATORS

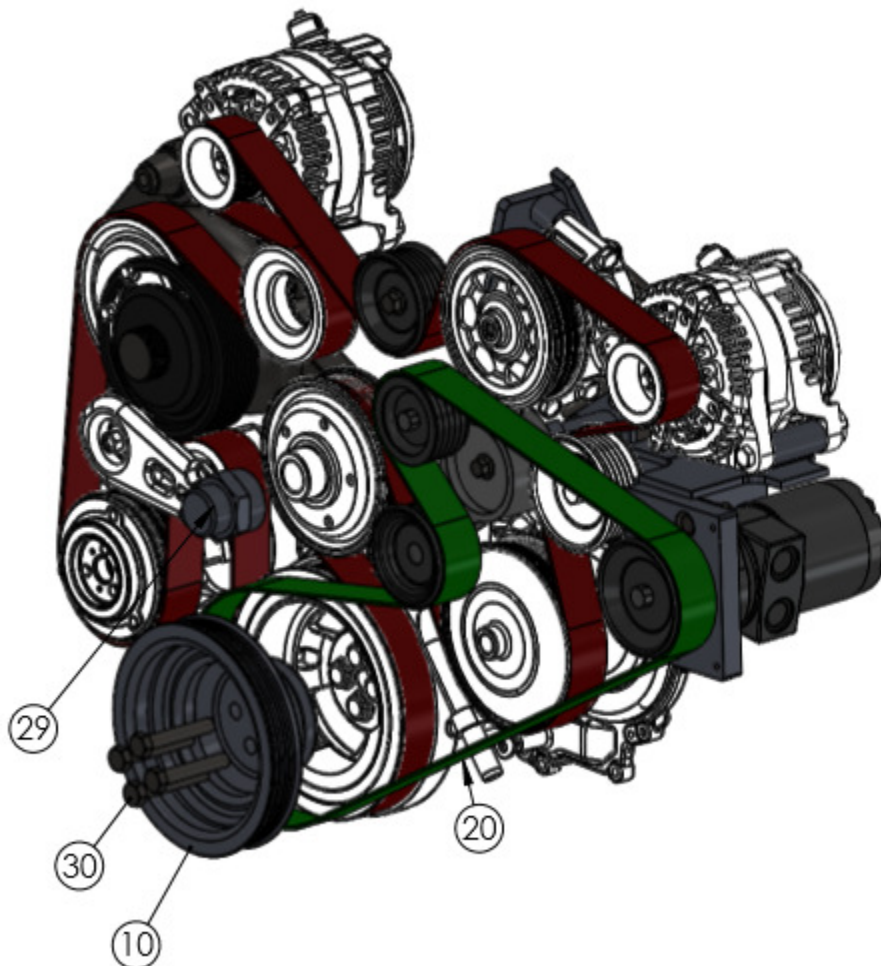
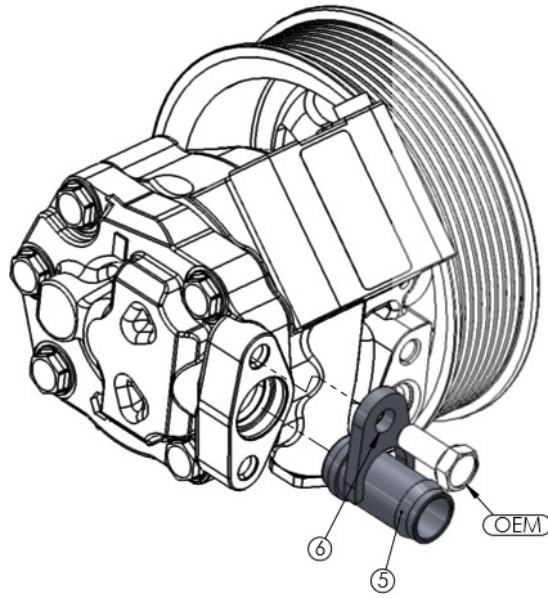

# FMK265A-8

2017 F-250-550

6.7L DIESEL

With DUAL ALTERNATORS

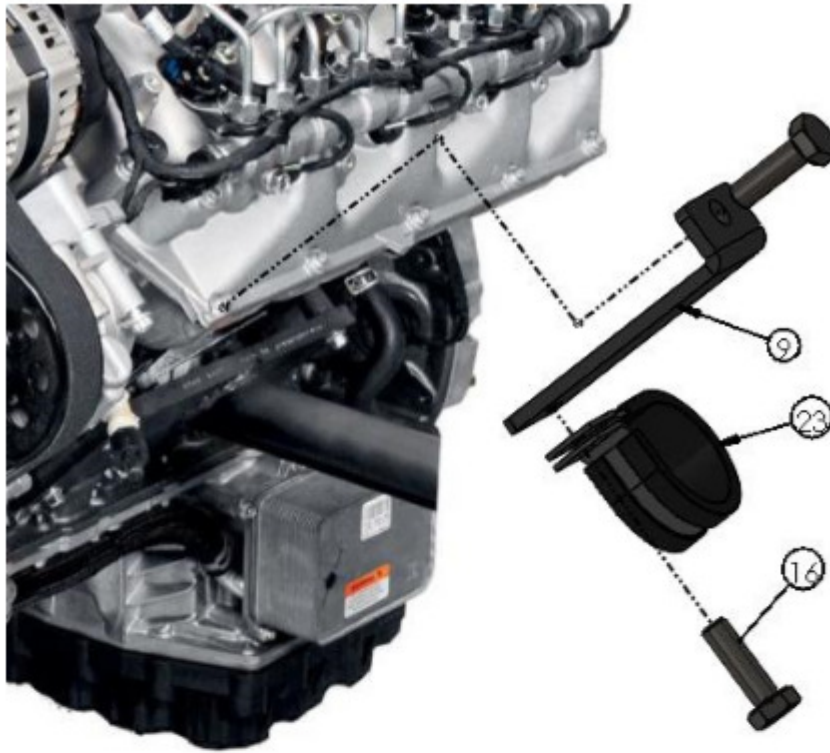

# FMK265A-8

2017 F-250-550

6.7L DIESEL

With DUAL ALTERNATORS

