

INSTALLATION NOTES

1. Disconnect negative battery cables. Remove the turbo cooler tube from the passenger side engine compartment. Remove the O.E.M. belt, alternator, alternator bracket, and lifting lug from the passenger side of the engine.
2. Install the pump bracket (1) with bolts (3). Torque bolts to 40 ft/lbs. Remove the top two air conditioner mounting bolts. Install bracket (2) with bolts (6) and lock washers (7). Do not tighten. Install bolts (5). Tighten bolts (5) and (6) finger tight; then torque bolts (5) to 40 ft. lbs. and bolts (6) to 25 ft. lbs.
3. Install the pump into bracket (1) with bolts (8), flat washers (9) lock washers (10), and nuts (11). Install the coil and clutch as per manufacturer instructions. Install idlers (15), bushings (16) and bolts (17) mounting the lower idler to inner most hole location. Torque bolt to 30 ft. lbs. Install the O.E.M. alternator with lock washers (4), spacers (18), and bolts (19). Install the new belt (20) according to the belt diagram. Lower idler may be adjusted to allow belt to be installed. Install O.E.M. turbo tube. Align the tube rest for best fit then tighten clamps securely.
4. Use the plastic tie straps supplied in the kit to secure any hoses, wires, etc. that may come in contact with any hot or moving parts. Reconnect battery cables. Run engine and check for proper belt tracking and clearances.

NOTE: Check all engine compartment vacuum hoses and electrical wiring that have been disturbed or re-routed during kit installation to be sure that hoses are not kinked, that they do not touch any high temperature item, and that they do not interfere with any linkage components.

FMK 274A-I8

2011-16 Ford 650 & 750

6.7 L Cummins

W/AC

W-W/O Air Brakes

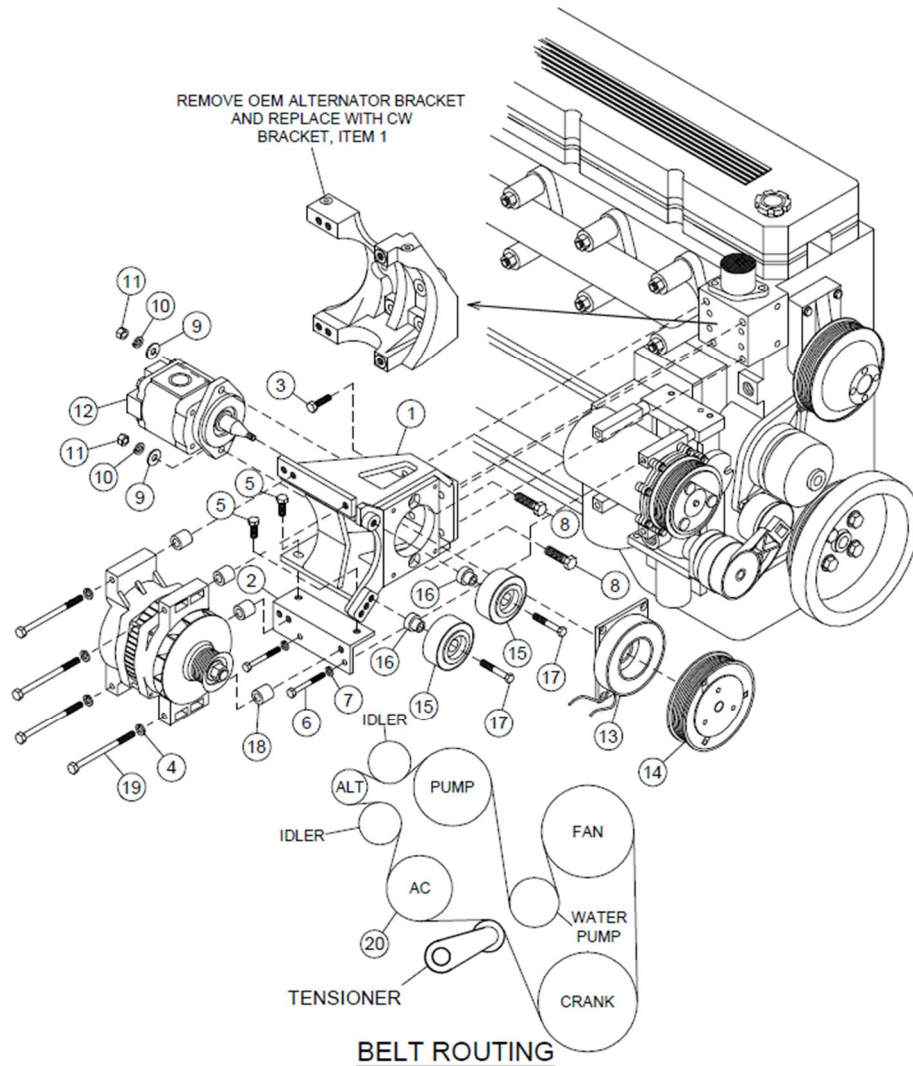

PARTS LIST

- | | |
|---|---------------------------------------|
| 1. FMB 273A (1) | 13. Coil (<i>Sold Separately</i>) |
| 2. FMB 2711 (1) | 14. Clutch (<i>Sold Separately</i>) |
| 3. 10mm x 30mm Flange Bolt (4) | 15. 89016 Dayco (2) |
| 4. 10mm LW (4) | 16. FMB 2731 (2) |
| 5. 10mm x 20mm Flange Bolt (2) | 17. 10mm x 40mm Flange Bolt (2) |
| 6. 8mm x 110mm (2) | 18. SP100-1.00 Spacer (4) |
| 7. 8mm LW (2) | 19. 10mm x 120mm Bolt (4) |
| 8. 3/8 x 1-1/2 Bolt (2) | 20. Belt, Dayco 5080980 |
| 9. 3/8 FW (2) | (Items Below Not Shown) |
| 10. 3/8 LW (2) | 22. Plastic Tie Strap (5) |
| 11. 3/8 Nut (2) | |
| 12. Clutch Pump Assembly (<i>Sold Separately</i>) | |