



CW MILL EQUIPMENT CO., INC.  
P.O. Box 246 • Sabetha, Kansas 66534  
(785) 284-3454 • FAX (785) 284-3601

**FPK 271A-I8**  
**2004-07 Ford 650 & 750**  
**5.9L Cummins**  
**W/O AC, W-W/O Air Brakes**

## INSTALLATION NOTES

---

1. Disconnect negative battery cable. Remove OEM belt and tensioner. Install bolts (5) with lockwashers (6) into plate (1) as shown in the illustration. Install plate (1) onto the engine with bolts (4) into the air conditioner location. Tighten bolts securely. Install A-mount adapter plate (2) onto plate (1) with bolts (5). Do Not Tighten.
2. Install pump (14) onto the adapter plate (2) with bolts (9), flatwashers (10), and lockwashers (6), nuts (11). Tighten bolts securely. Install the coil and clutch per manufacturer's instructions. Using a straight edge, make certain the clutch pulley is parallel with the accessory pulleys, then tighten bolts (5) securely. Install both gussets (3) with bolts (7) and lockwashers (8), tighten bolts securely.
3. Install the new tensioner (12) onto the lower tensioner mounting location using bolt (13). Install the new belt (17) onto the engine according to the belt diagram. Check all hoses, wires, etc., that may have been disturbed during installation to make sure they do not come in contact with any hot or moving parts.

# FPK 271A-I8

2004-07 Ford 650 & 750

5.9L Cummins

W/O AC

W-W/O Air Brakes

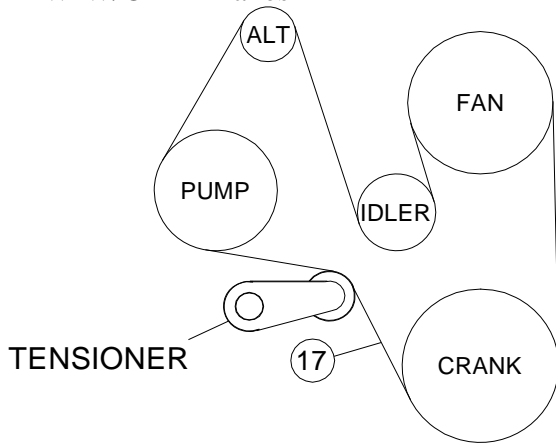

## BELT ROUTING

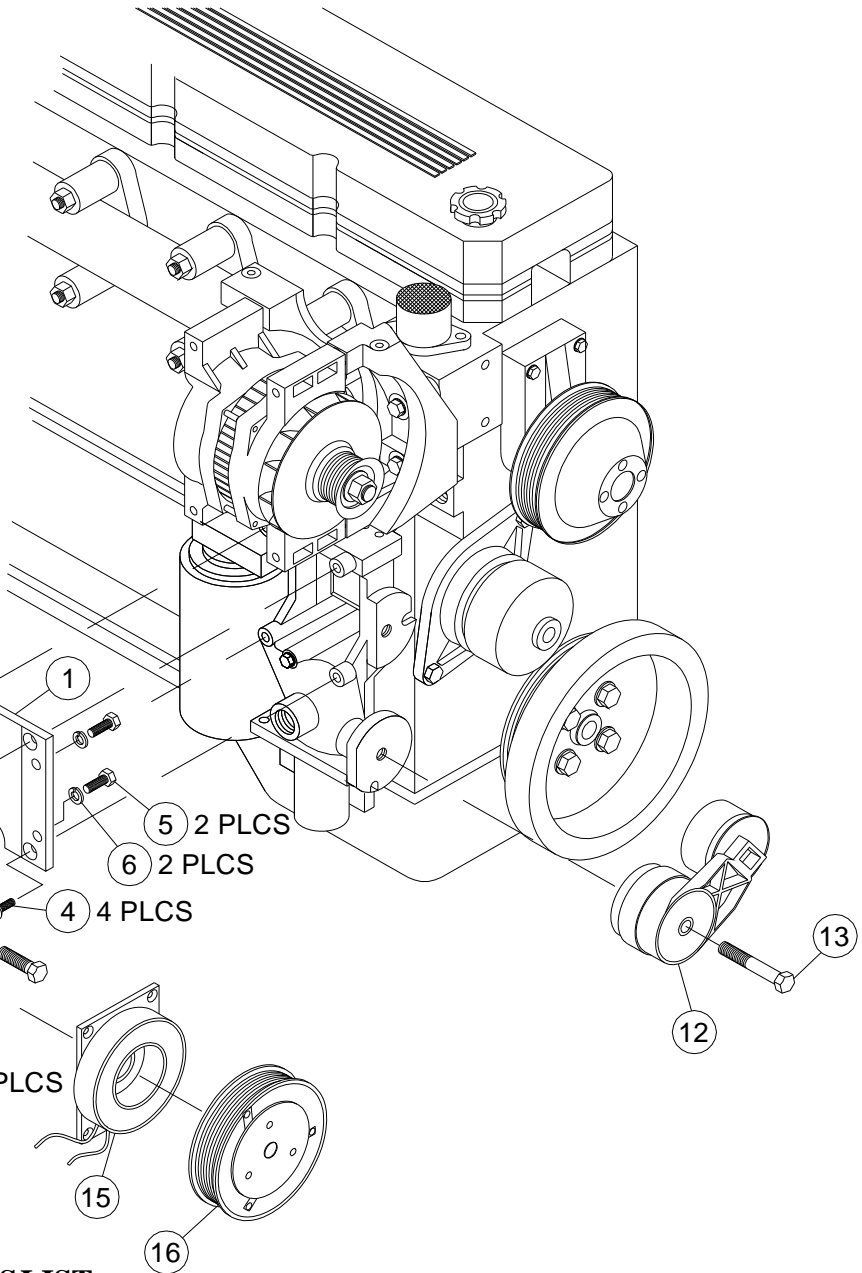

## PARTSLIST

- |                         |   |
|-------------------------|---|
| 1. FMP 53AI8 (1)        | 10. 3/8 FW (2)                                |
| 2. PBL2M (1)            | 11. 3/8 Nut (2)                               |
| 3. FMB53I81 (2)         | 12. 89200B Tensioner                          |
| 4. 8mm x 50mm FHSCS (4) | 13. 10mm x 80mm 10.9 (1)                      |
| 5. 3/8 x 1 Bolt (2)     | 14. Clutch Pump Assembly<br>(Sold Separately) |
| 6. 3/8 LW (4)           | 15. Coil                                      |
| 7. 1/4 x 3/4 Bolt (6)   | 16. Clutch                                    |
| 8. 1/4 LW (6)           | 17. Belt; Dayco 5080820 (1)                   |
| 9. 3/8 x 1-1/2 Bolt (2) |   |