



CW MILL EQUIPMENT CO., INC.
P.O. Box 246 • Sabetha, Kansas 66534
(785) 284-3454 • FAX (785) 284-3601

IMK 61 — 2 Belts
1983-92 INTERNATIONAL
6.9,7.3 W-WO/HD ALT., P.S.
W-WO/AC, WO/AIR BRAKES

INSTALLATION NOTES

1. Disconnect battery, drain radiator, and loosen belts. Mark fan clutch to water pump pulley for proper re-installation, remove fan.
2. Remove bolts from crankshaft pulley and install drive pulley (1).
CAUTION: Be sure new bolts have same threads as O.E.M. bolts removed.
NOTE: It may be necessary to move radiator forward for access.
3. Install fan spacer and fan.
NOTE: Align marks from step #1.
4. Replace lower power steering bracket with pump mounting bracket (8). Use spacers (11) with bolts (13) on front mounting holes (A & B). Use spacer (10) with O.E.M. bolt on rear mounting hole (F). Install power steering pump at location (C,D, & E).
5. It is necessary to relocate coolant fill line for clutch pump clearance. Plug original location, using fittings (20,21, & 22), move to lower hole in block. Cut hose (19) to necessary length.
6. Install clutch pump to pump plate loosely. Bolt plate to bracket. Align clutch pump to drive pulley. Tighten pump bolts.
7. Install pump drive belts (23) and adjust clutch pump to tension belts. Tension O.E.M. belts, install pump.
8. Secure radiator if removed; fill with coolant. Connect battery.

CAUTION: Check all engine compartment vacuum hoses and electrical wiring that may have been disturbed or re-routed during kit installation to be sure that hoses are not kinked, that they do not touch any high temperature item, and that they do not interfere with any linkage components.

NOTE: This kit is designed to operate successfully with the standard fan supplied by the manufacturer of your truck. Due to O.E.M. assembly tolerances, visually make certain that there is adequate clearance between fan and drive pulley, and also fan and radiator. It may be necessary to use a longer spacer for pulley clearance. If there is little clearance to the radiator, check to insure that it will not flex into the radiator before operating

IMK 61 - 2 Belts

1983-92 INTERNATIONAL 6.9,7.3

W-WO/AC,HD ALT.,WO/AIR BRAKES,W/PS

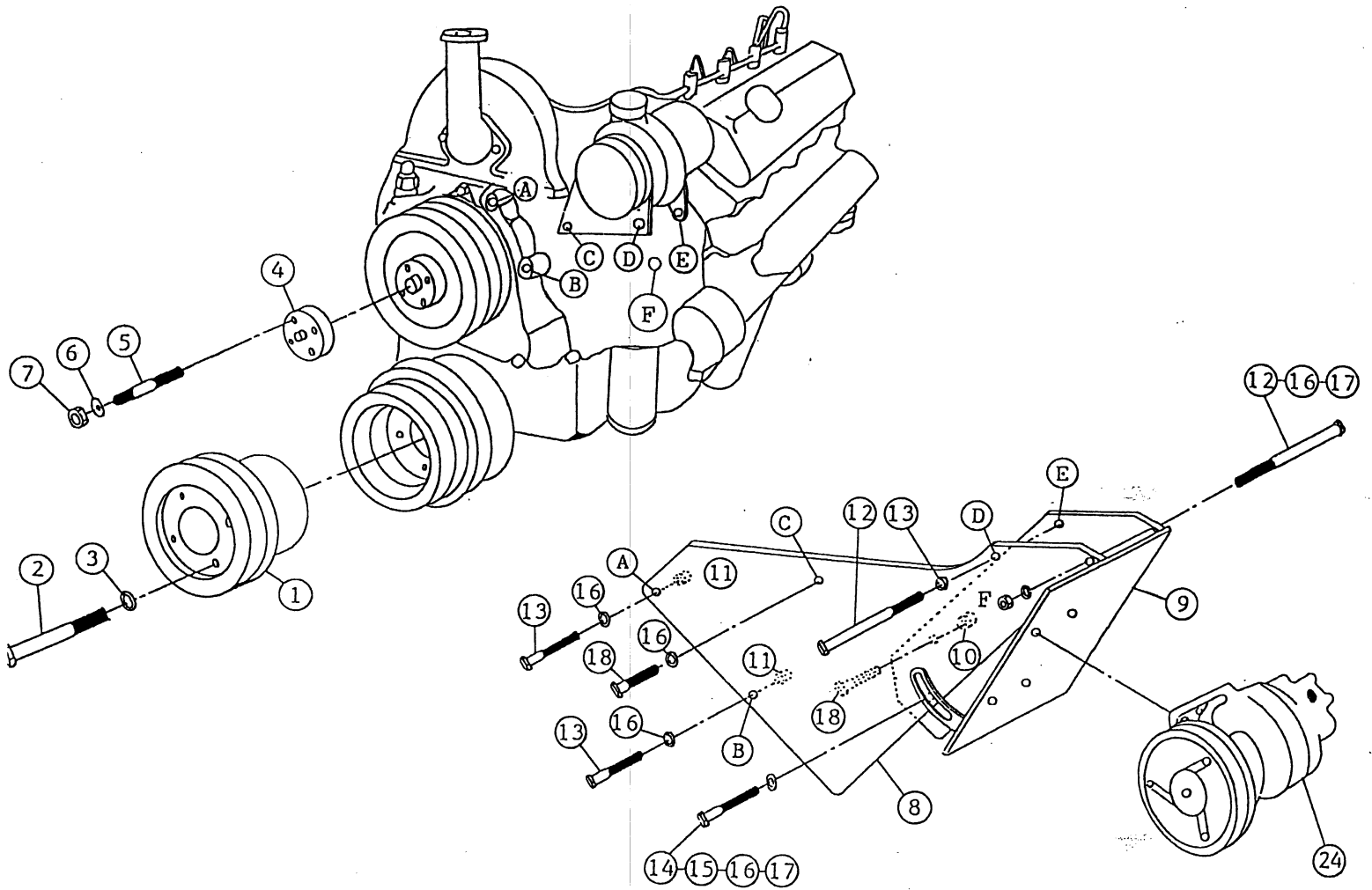

PARTS LIST

- | | |
|-------------------------|--|
| 1. IPC 612 (1) | 13. 3/8 X 1 3/4 NC (2) |
| 2. 3/8 X 4 NC (4) | 14. 3/8 X 1 1/2 NC (2) |
| 3. 3/8 LW (4) | 15. 3/8 FW (1) |
| 4. FSO 606 (1) | 16. 3/8 LW (5) |
| 5. 5/16 X 2 1/2 DST (4) | 17. 3/8 NC (2) |
| 6. 5/16 LW (4) | 18. O.E.M. |
| 7. 5/16 NF (4) | 19. 1" X 48" Hose (1) |
| 8. IMB 610 (1) | 20. 1/2 Close Nipple (1) |
| 9. IMP 61(0-4) (1) | 21. 3/4 X 1/2 Bell Red. (1) |
| 10. SP88-0.500 (1) | 22. 3/4 St. Elbow (1) |
| 11. SP88-0.375 (2) | 23. A52K (2) (Not Shown) (#2 A50K,#4 A50K) |
| 12. 3/8 X 5 1/2 NC (2) | 24. Clutch Pump Assembly (1) |
| | (Sold Separately) |

NOTE: 7" clutch #2 A51K, #4 A50K.