



CW MILL EQUIPMENT CO., INC.  
P.O. Box 246 • Sabetha, Kansas 66534  
(785) 284-3454 • FAX (785) 284-3601

## SMK 37-I6 Belts

2003-09, 2012 ISUZU  
6.0L(GM)  
W-W/OAC

---

### INSTALLATION NOTES

---

1. Remove O.E.M. belt. Remove bolts from locations “A”, “B”, & “C”. Remove clamp from wire loom clamp located on the driver side frame, and turn upside down, and reinstall it back to it’s original mounting hole. This is done to gain more clearance between the wire loom and the clutch pump. Remove O.E.M. vacuum pump; it will not be reused. Twist the tab from the center vacuum port on the passenger side of the intake manifold. This will supply a vacuum source to replace the belt drive vacuum pump. Install the small end of the vacuum hose (12) onto the intake, and route it over, and attach it to the steel vacuum line located on the top of the driver’s side frame rail.
2. Install pump bracket (1) using spacer (2) behind the bracket at location “A”, and bolts (3), with lockwashers (4) at locations “A”, “B”, and “C”. Torque bolts to 35 ft/lbs. Install brace (5) to back of bracket (1) using bolts (7), flatwashers (8), and lockwashers (4), and to the engine at location “D: using bolt (6) with lockwasher (4). Tighten bolts evenly, then torque them to 35 ft/lbs.
3. Install the clutch pump onto bracket (1) with bolts provided in the kit. Tighten securely. Install one of the idler assemblies (8, 9, 10, 11) onto the bracket (1) at location “E” Install the belt 19 onto the engine as shown in the diagram. With the belt tensioner fully compressed, install the other idler assembly (8, 9, 10, 11) in the lowest hole possible at locations “F”. Tighten the idler bolt and release the tensioner.

**Caution:** Check all engine compartment hoses and wiring to insure they are not kinked, touching any high temperature components, coming in contact with any moving parts, or interfering with any linkage.

**SMK 37-I6 Belts**  
**2003-09, 2012 ISUZU**  
**6.0L(GM)**  
**W-W/OAC**

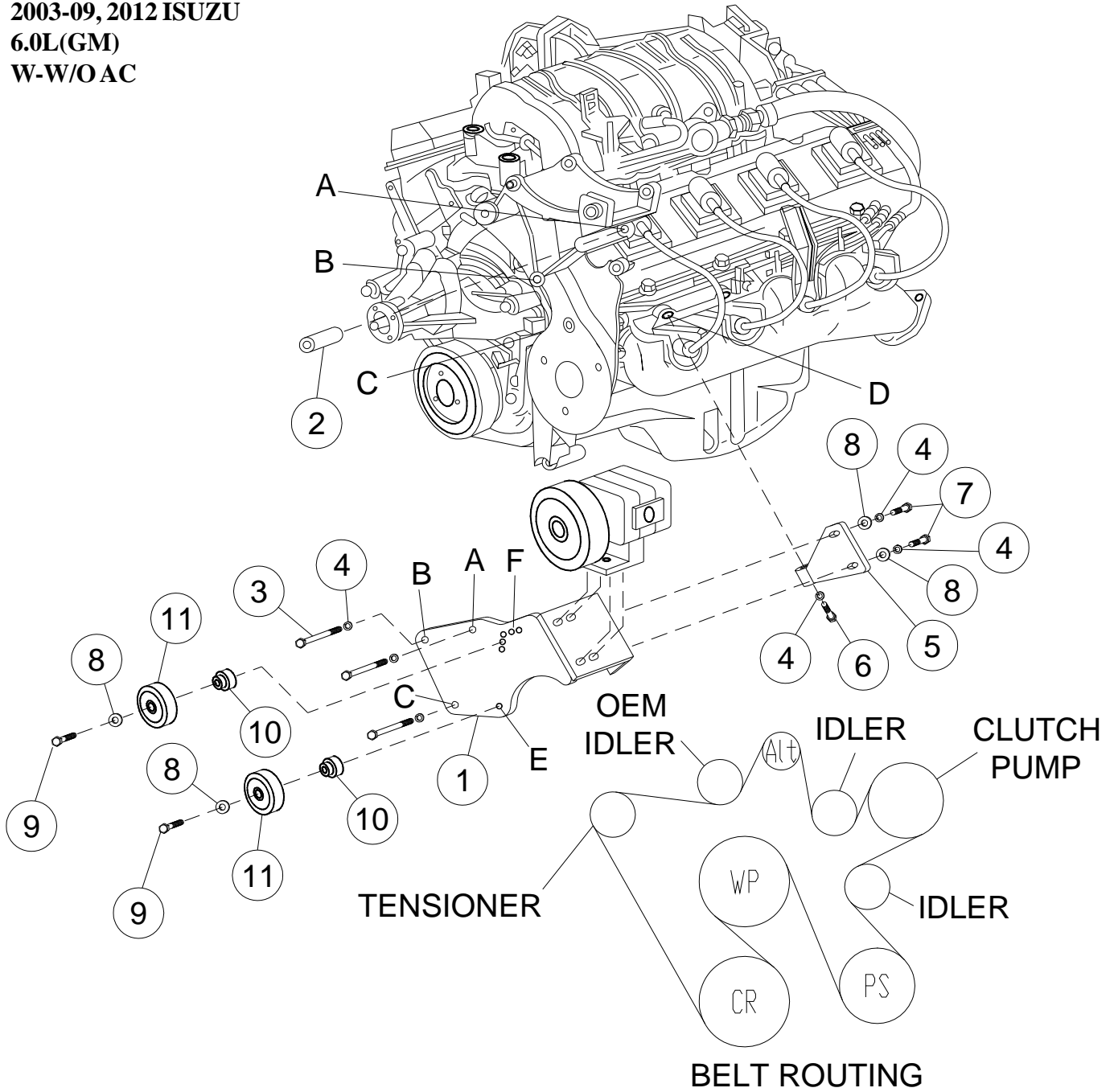

**PARTS LIST**

- |                     |   |
|---------------------|---|
| 1. SMB 371 (1)      | 9. 10mm x 55mm (2)                                |
| 2. SP100-3/293 (1)  | 10. SMB 373 (2)                                   |
| 3. 10mm x 120mm (3) | 11. TIPCS (2)                                     |
| 4. 10mm LW (6)      | 12. Vacuum Line Assembly (1)<br>(SM37VH)          |
| 5. SMB 372 (1)      | 13. Clutch Pump Assembly (1)<br>(Sold Separately) |
| 6. 10mm x 45mm (1)  | 14. 5061223 Dayco                                 |
| 7. 10mm x 25mm (2)  |   |
| 8. 10mm FW (4)      |   |