



CW MILL EQUIPMENT CO., INC.  
P.O. Box 246 • Sabetha, Kansas 66534  
(785) 284-3454 • FAX (785) 284-3601

## **STMK61A-I8**

**2000-04 Sterling Acctera**  
**2000-01 Freightliner M2**  
**MBE 900 Mercedes-Benz 6 cyl.**  
**WO AC, W-W/O Air Brakes**  
**W/2 Bolt Alternator**

### **INSTALLATION NOTES**

1. Disconnect the negative battery cable(s). Remove the engine accessory drive belt and the alternator. Using a jack or other suitable tool, support the front of the engine; then remove the lower alternator bracket/motor mount and the upper alternator brace from the engine. Remove the two alignment bushings from the motor mount and install them into the new pump bracket at hole locations A and B.
2. Install the pump bracket (1) onto the engine at the same location that the alternator bracket was using; Re-use the O.E.M. bolts. Torque the 12mm bolts to 75-80 ft. lbs., and the 14mm bolts to 115-125 ft. lbs. Install bushing (2) between the engine and the bracket at location (F) and secure it with bolt (3), lock washer (4), and flat washer (5). Torque bolt (3) to 35-40 ft. lbs.
3. Install the clutch pump onto the bracket with bolts (12), flat washers (13), lock washers (14), and nuts (15). Torque nuts to 35 ft. lbs. Install bracket (6) onto the engine with bolt (7) lock washer (4) in location (C). **DO NOT TIGHTEN.** Install the alternator with the O.E.M. bolts. Torque bolt (7) to 35-40 ft. lbs. and the alternator bolts to 40-45 ft. lbs. Install the coil and clutch as per manufacture's instructions. Install idler (8) with bushing (9), flatwasher (11), and bolt (10). Torque bolt (10) to 40 ft. lbs.
4. Remove the O.E.M. belt tensioner and replace it with the new tensioner (16); Re-use the O.E.M. bolt. Torque bolt to 30-35 ft. lbs. Install the drive belt (17) and route it according to the belt diagram. Connect the battery cable(s). Run the engine to check for proper belt tracking.

Note: Make certain any hoses, wires etc., that were disturbed during installation are not against any hot or moving parts.

# STMK61A-I8

2000-04 Sterling Acctera

2000-01 Freightliner M2

MBE 900 Mercedes-Benz 6 cyl.

WO AC, W-W/O Air Brakes

W/2 Bolt Alternator

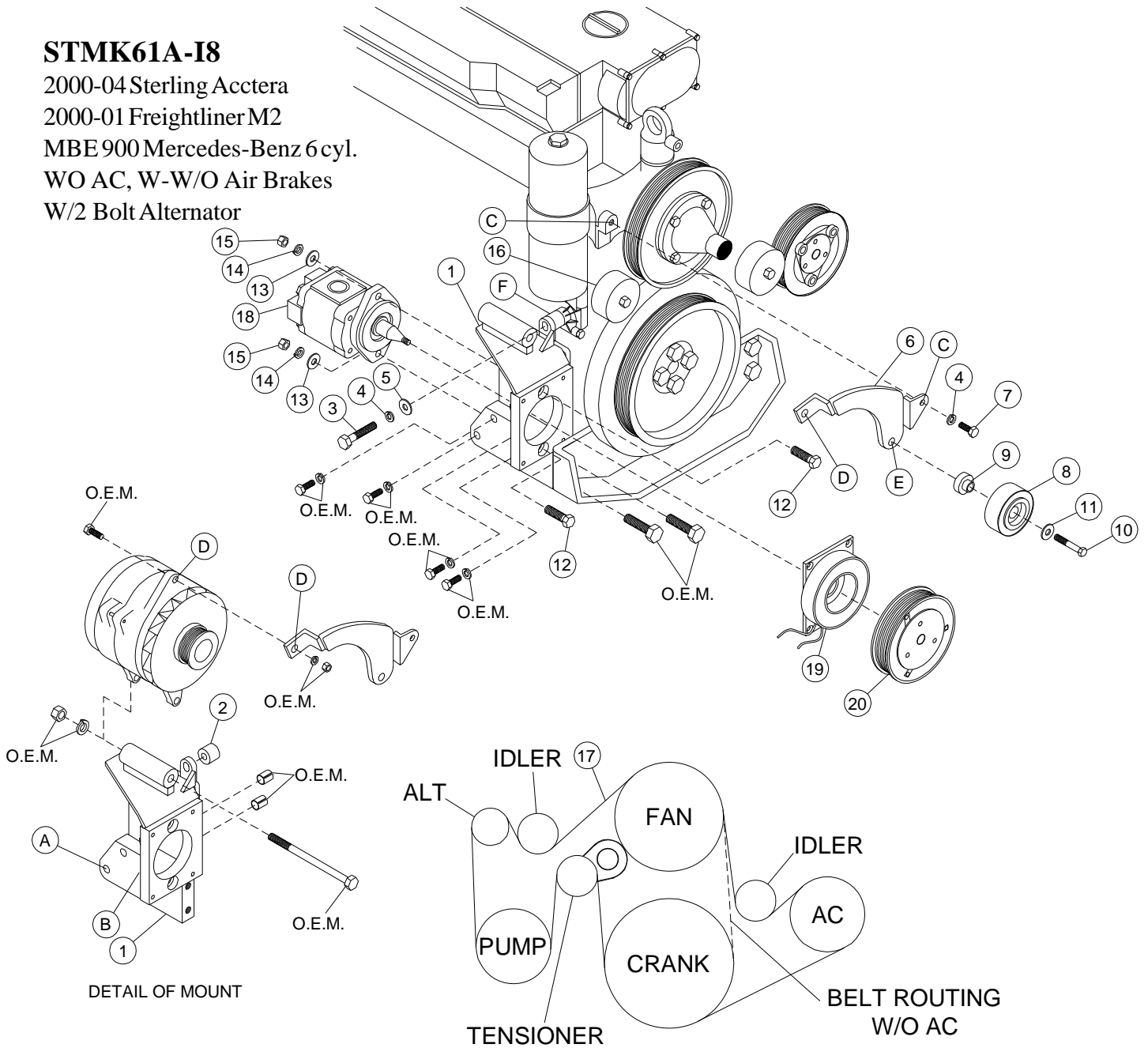

## BELT ROUTING

### PARTSLIST

- |                               |   |
|-------------------------------|---|
| 1. STMP 61A (1)               | 11. 12mm FW (1)                           |
| 2. SP100-.813 (1)             | 12. 3/8-16 x 1-1/2 bolt (2)               |
| 3. 10mm x 45mm x 1.5 bolt (1) | 13. 3/8 FW (2)                            |
| 4. 10-mm LW (2)               | 14. 3/8 LW (2)                            |
| 5. 10mm FW (1)                | 15. 3/8-16 nut (2)                        |
| 6. STMB 611 (1)               | 16. Tensioner A906 200 2470 Mercedes Benz |
| 7. 10mm x 25mm x 1.5 bolt (1) | 17. 5080805 Dayco Belt (1)                |
| 8. TIPCS Idler (1)            | 18. Clutch Pump (sold separately)         |
| 9. STMB 612 (1)               | 19. Coil (sold separately)                |
| 10. 12mm x 40mm bolt (1)      | 20. Clutch (sold separately)              |