



**CMK 37SD508-I6**  
**1996-2000 CHEVY TRUCK**  
**C&K 1500,2500,3500**  
**305, 350 W/AC**  
**W-WO Dual Battery**  
**(Serpentine)**

## INSTALLATION NOTES

---

1. Disconnect negative battery terminal. Remove the air cleaner assembly and the top half of the fan shroud. Remove the fan and the serpentine belt. Fan nut has right hand threads.
2. Remove the alternator, tensioner, idler and hose standoff from the OEM alternator bracket. Remove the bracket and stud bolt from the engine, and the steel bushings from the OEM alternator bracket.
3. Install the OEM steel bushings into the new bracket (1) the same way they were in the OEM bracket. Install bracket (1) onto the engine with bolts (3) at locations "A & B" and bolt (4) with lock washer (2) at location "C". Tighten bolts securely. Install the OEM idler and the alternator onto the new bracket with OEM bolts. Install the tensioner (6) onto the bracket with bolt (5).
4. Install aux. A.C. compressor (15) with bolts (11,12), nuts (13) and slide bushings (14). Install idler (9) onto the main bracket into the lowest tapped hole with bolt (7), flat washer (8), and bushing (10). Install the new belt (16) onto the engine and route it according to the diagram. If the belt is too short, move idler (9) up one hole until the belt can be installed.
5. Install the fan, the fan shroud and the air cleaner assembly. Connect the battery cable. Run the engine to make sure the belt tracks properly and is seated in all the pulleys correctly.

**CAUTION:** Check compartment vacuum hoses and electrical wiring that may have been disturbed or re-routed during kit installation to be sure that hoses are not kinked, do not touch any high temperature item, and do not interfere with any linkage components.

# CMK 37SD508-I6

1996-2000 Chevy Truck

305, 350 W/AC

W-WO Dual Battery

(Serpentine)

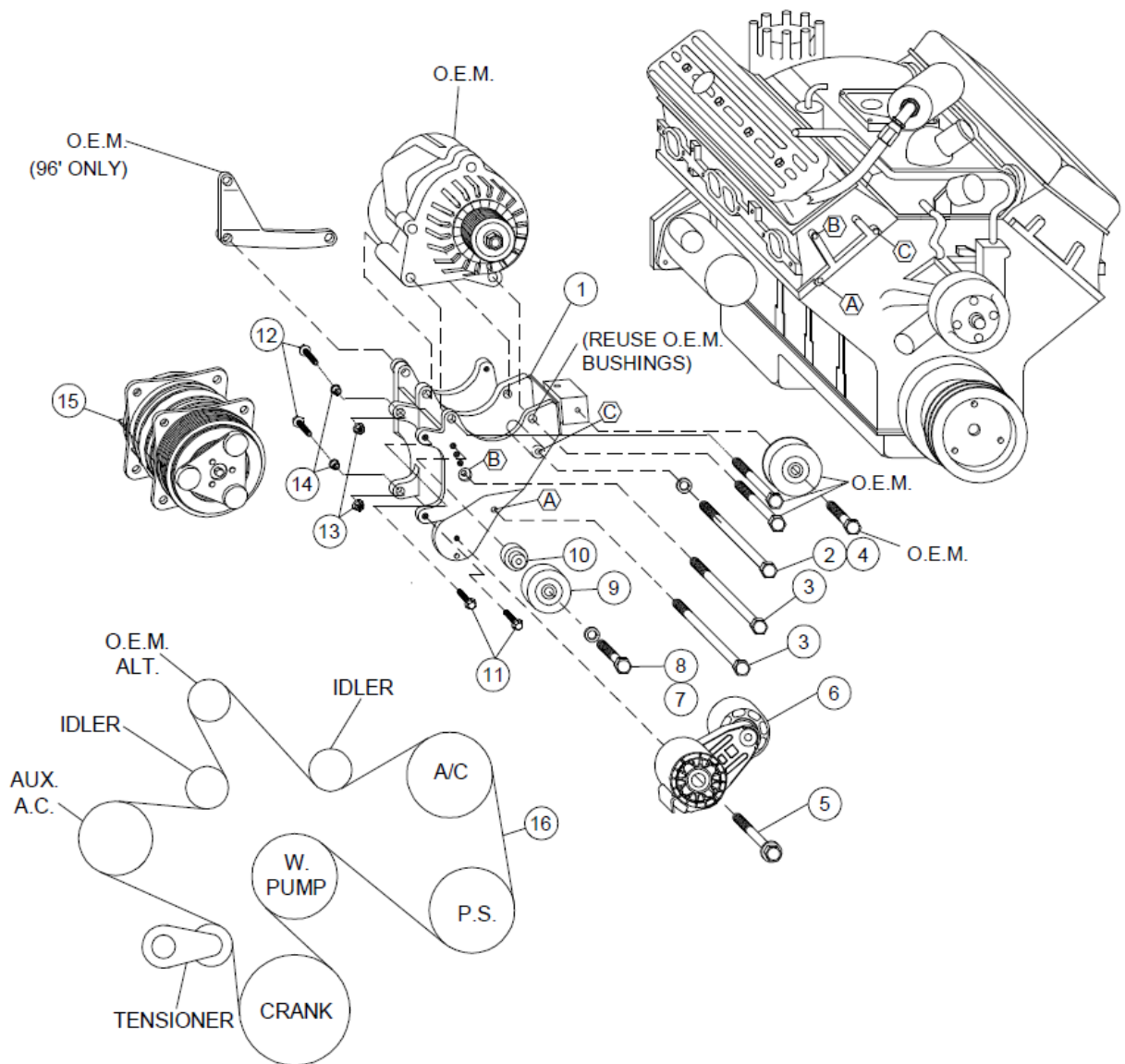

## PARTS LIST

- |                         |   |
|-------------------------|---|
| 1. CMP 37SD508-I6 (1)   | 10. CMB 372 Bushing (1)                   |
| 2. 3/8 LW (1)           | 11. 10mm x 30mm Flange (2)                |
| 3. 3/8 X 5-3/4 GR 8 (2) | 12. 10mm x 40mm Flange (2)                |
| 4. 3/8 X 6 GR 8 (1)     | 13. 10mm Flange Nut (2)                   |
| 5. 10mm X 80mm (1)      | 14. 1255-0090 Slide Bushing (2)           |
| 6. Dayco 89200B         | 15. A.C. Compressor (1) (Sold Separately) |
| 7. 12mm x 45mm (1)      | 16. 5061150 Dayco (1)                     |
| 8. 12mm FW (1)          |   |
| 9. TIPCS (1)            |   |