



CW MILL EQUIPMENT CO., INC.  
P.O. Box 246 • Sabetha, Kansas 66534  
(785) 284-3454 • FAX (785) 284-3601

## DMK 58SD508-I8AT

2011-2013 Dodge D-2500-5500

Not for 2013 with remote P.S. reservoir

6.7 Cummins Diesel

W-AC

### INSTALLATION NOTES

1. Drain radiator below upper radiator hose. Remove hose. Remove fan and fan shroud. Remove driver side upper shroud support. Remove belt. Remove return hose from power steering reservoir and let reservoir drain. Remove bolts from power steering pump through the holes in the pulley. Leaving pressure lines attached, set pump aside on passenger side of engine. Remove power steering pump brackets.
2. *(If not installing on a 2012 or newer truck with an automatic transmission skip to step 3).* Remove automatic transmission cooler lines from radiator side by removing quick clips. Drain fluid out of lines. Mark cooler lines in approximate location that they should be cut looking at the illustration. Check location by routing replacement hoses(20) and adjust cut location if necessary. Cut with a tubing cutter and discard radiator side of the O.E.M. lines. Install new hoses(20) as shown in illustration. **Note:** *Make sure to get compression fittings tight. Pressures in these lines may reach up to 300psi.*
3. Install studs (2) in timing cover w/nuts (5). Install aux. A.C. onto bracket using bolts (11,13), slide bushings (12) and nuts (14). Install 5/8 hose(15) onto return hose using hose barb (17) and hose clamps(16). Power steering hoses may need moved in order to gain appropriate clearance to air conditioner compressor.
4. Install aux. A.C. and bracket assembly onto studs (2) using nuts(5). Check alignment on compressor and adjust with shims if necessary. NOTE: It may be easier to install hoses and power wire before power steering pump is reinstalled. Install power steering pump onto bracket using bolts (6) and LW's (4). Hose on power steering pump will need to be rotated and bent slightly for clearance. **Note:** *Be careful not to kink power steering lines.* Install new belt (19) according to the belt diagram. Install idler (9) in lowest hole location possible while tensioner is retracted fully using bolt (13) and bushing (10).
5. Install hose rest(7) to head on driver side using flange head bolts(8). Cut 3/4" off radiator side of upper radiator hose and reinstall. Connect new power steering return hose (15) to power steering reservoir using hose barb (17) and hose clamps (16). Fill power steering reservoir w/ATF Plus 4 transmission fluid. *(If installing on a 2012 or newer truck with an automatic transmission)* Top off transmission w/ ATF Plus 4 transmission fluid. Reinstall fan and fan shroud. Fill radiator and overflow tank. Check for proper belt tracking and clearances.

# DMK 58SD508-I8AT

2011-2013 Dodge Truck 2500-5500

Not for 2013 with remote P.S. reservoir

6.7 Cummins Diesel

W-AC

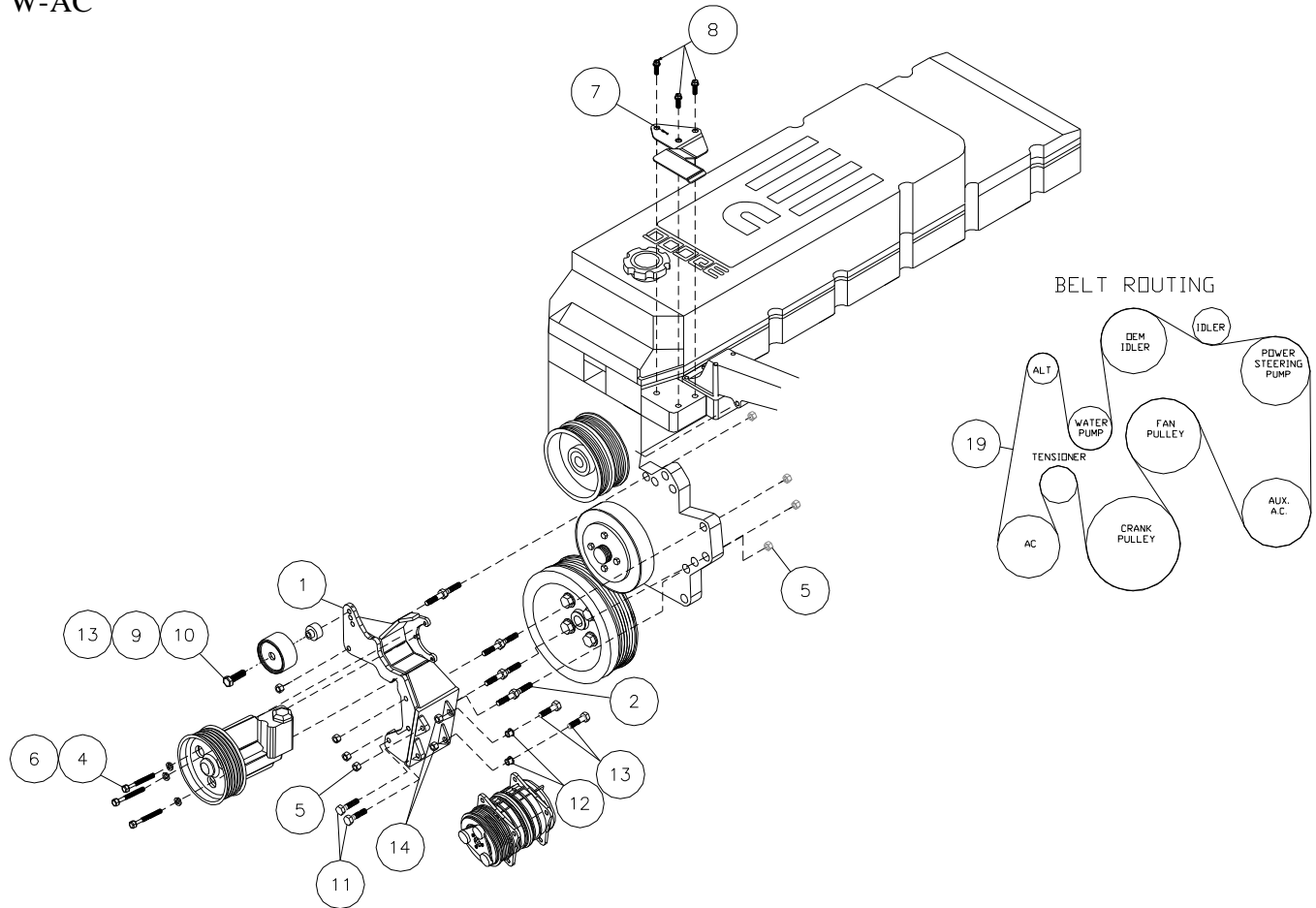

## PARTS LIST

- |     |                             |     |                                |
|-----|-----------------------------|-----|--------------------------------|
| 1.  | DMP58SD508-I8 (1)           | 11. | 10mm x 30mm Flange Bolt (2)    |
| 2.  | 8mm Stud 08075-1.24 ST (4)  | 12. | 1255-0090 Slide Bushing (2)    |
| 3.  | 8mm Nut (1)                 | 13. | 10mm x 40mm Flange Bolt (3)    |
| 4.  | 8mm LW (3)                  | 14. | 10mm Flange Nut (2)            |
| 5.  | 8mm Flange Nut (8)          | 15. | 14"-5/8 Oil Hose (1)           |
| 6.  | 8mm X 80mm Bolt (3)         | 16. | #10 Hose Clamp (2)             |
| 7.  | DMB583 (1)                  | 17. | 5/8 Double Ended Hose Barb (1) |
| 8.  | 10mm X 20mm Flange Bolt (3) | 18. | 15" Plastic Tie (1)            |
| 9.  | 89016 Dayco (1)             | 19. | 5081300 Belt (1)               |
| 10. | DMB 562 (1)                 | 20. | D58TCHK (1)                    |