



FLMK70SD508-8
2011-2016 FREIGHTLINER M2
CUMMINS ISB 6.7L

INSTALLATION NOTES

1. Disconnect negative battery cable. Remove driver's side radiator support brace. Remove the OEM belt. Remove the four bolts holding the fan to the fan pulley and let fan lay inside the fan shroud. Be careful not to damage the radiator. Install new drive pulley (1) with new compressor drive belt (10) draped over the top of drive pulley (1) using bolts (2) going through the fan, compressor drive pulley (1), then OEM fan pulley. Reinstall OEM belt. Tighten bolts to 45 ft.lbs..
2. Remove the radiator support bracket from the cylinder head and install the compressor bracket (3) in its place reusing O.E.M. bolts. Do not tighten at this time. Install the compressor onto bracket (3) using bolts (4,7), nuts (8) and slide bushings (9). Washer shims usually are not required, but may be required to properly align the compressor. With the compressor installed on the bracket, align the compressor parallel with the pulley (1) then tighten the compressor bracket bolts (4).
3. Install the tensioner (5) onto the bracket (3) using bolt (6). Install new compressor drive belt (10). Install the radiator support brace with original bolts. Connect the battery cable. Run the engine and check for proper belt tracking and adjust if necessary.

NOTE: Check all wires and hoses that may have been disturbed during installation to make sure they are not up against any hot or moving parts.

FLMK70SD508-8

2011-2016 FREIGHTLINER M2

CUMMINS ISB 6.7L

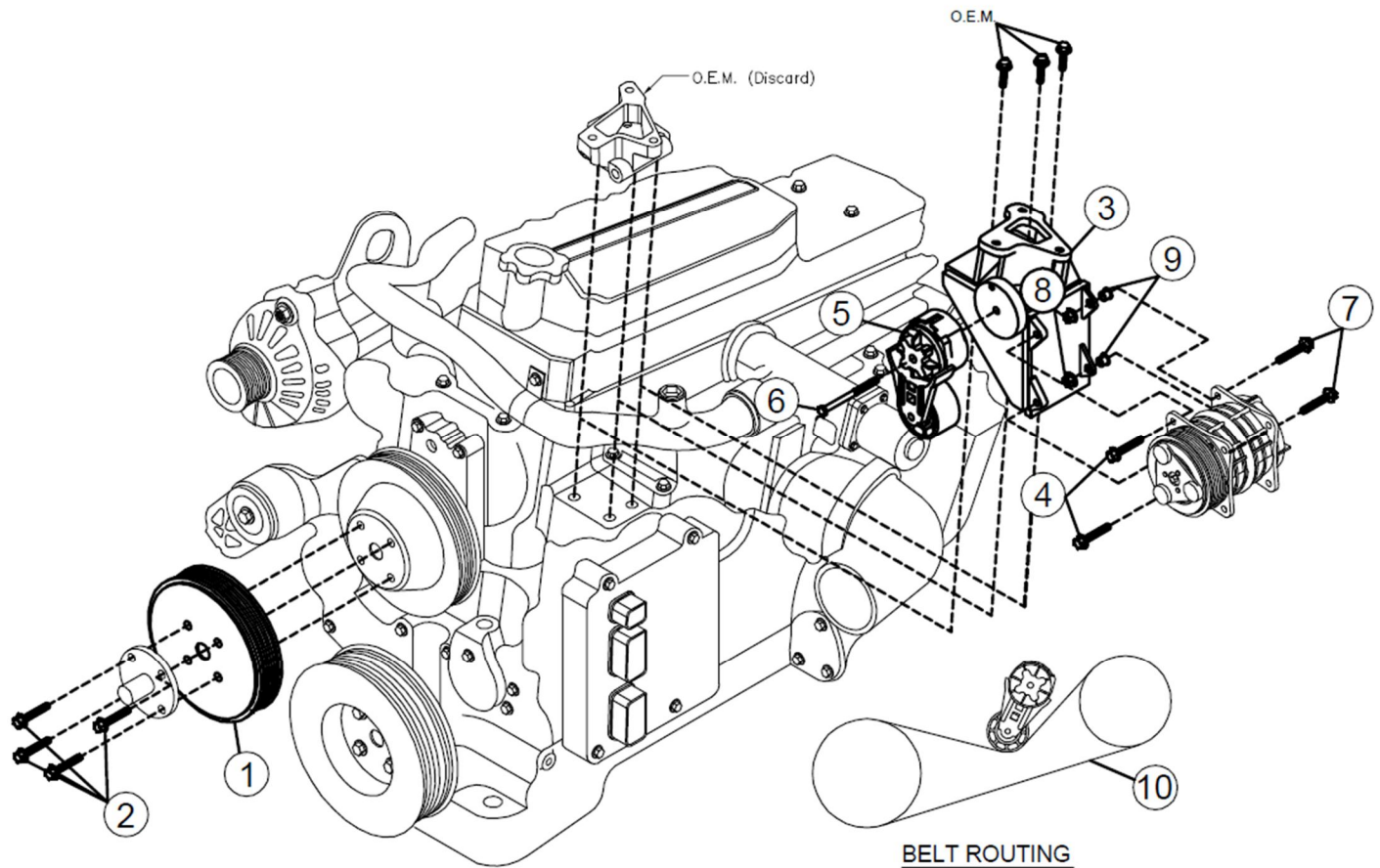

PARTS LIST

- | | |
|--------------------------------|--------------------------------|
| 1. FLPC708 (1) | 6. 10mm x 80mm MOD (1) |
| 2. 10mm x 30mm Flange Bolt (4) | 7. 10mm x 40mm Flange Bolt (2) |
| 3. FLMP70SD508-8 (1) | 8. 10mm Flange Nut (2) |
| 4. 10mm x 30mm Flange Bolt (2) | 9. 1255-0090 Slide Bushing (2) |
| 5. 89200B (1) | 10. Dayco 5080430 |