



CW MILL EQUIPMENT CO., INC.
P.O. Box 246 • Sabetha, Kansas 66534
(785) 284-3454 • FAX (785) 284-3601

FLMK 92SD508-8

**2004-09 Sterling Acctera
3126, C7 CAT Diesel
W-W/O AC, W-W/O Air Brakes**

INSTALLATION NOTES

1. Remove the eight bolts holding the damper onto the crankshaft. Install pulley (1) between the damper and the O.E.M. pulley using bolts (3) and lockwashers (2). Torque bolts to 40 ft.lbs..
2. Install aux. A.C. bracket (4) with bolts (5) and lockwashers (2) onto the engine as shown in the illustration. If vehicle is equipped with air brakes, fitting (10) must be used to reroute the pop-off valve for hose clearance.
3. Install the aux. A.C. compressor onto bracket (4) with bolts (11,12), nuts (13) and slide bushings (14). Install tensioner (6) with bolt (7). Install belt (9) according to belt diagram. Check for proper belt tensioning and clearances to any moving parts. Run engine and check for proper tracking of the belt, adjust if necessary.

FLMK 92SD508-8

2004-09 Sterling Acctera

3126, C7 CAT Diesel

W-W/O AC

W-W/O Air Brakes

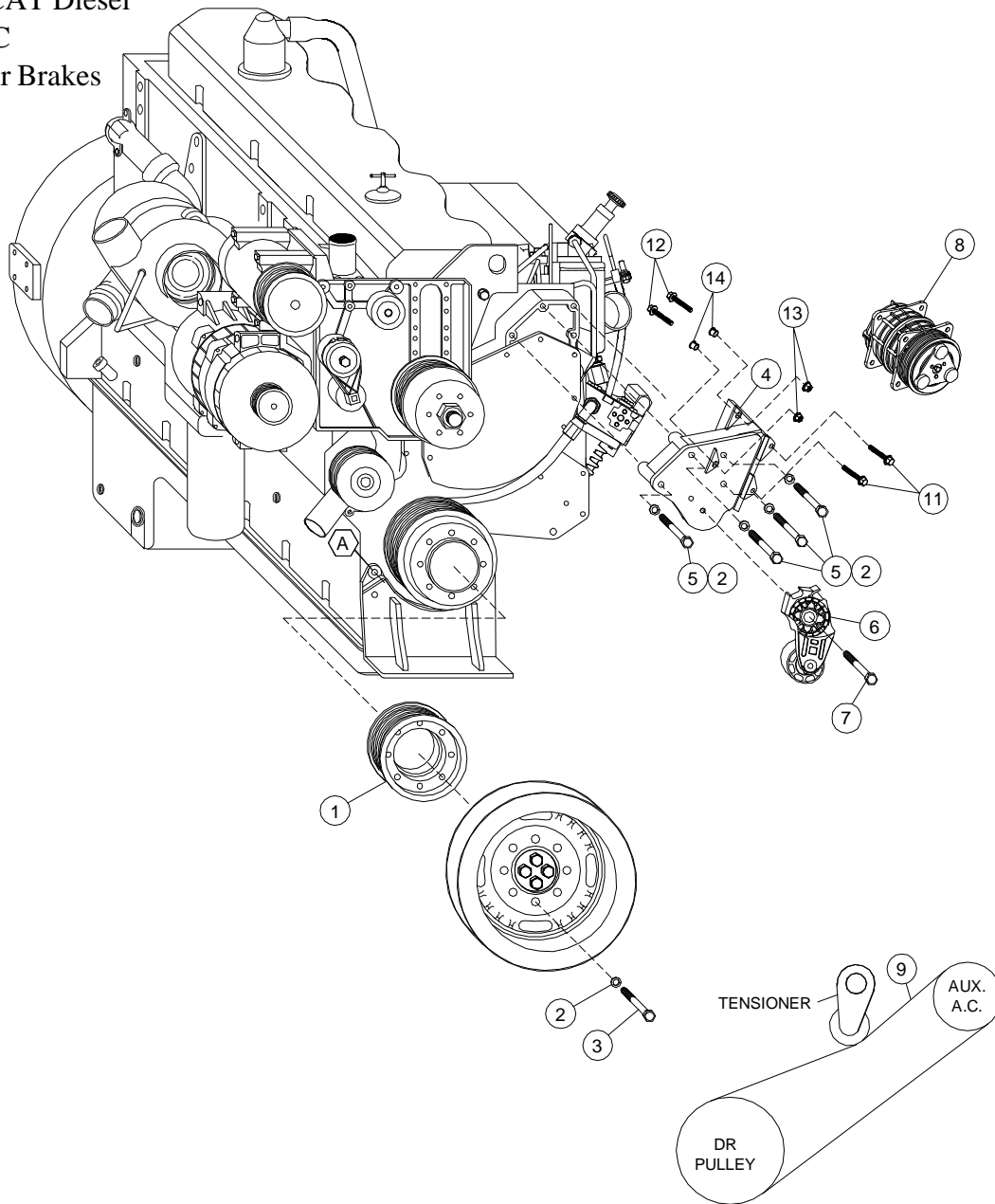

BELT DIAGRAM

PARTSLIST

- | | |
|-------------------------|--|
| 1. FPC 938 (1) | 8. A.C. Compressor (Sold Separately) |
| 2. 10mm LW (15) | 9. 5080625 Dayco |
| 3. 10mm x 65mm (8) | 10. 5500-8 Elbow Thompkins (not shown) |
| 4. IMP 63SD508-8 | 11. 10mm x 30mm Flange (2) |
| 5. 10mm x 80mm (4) | 12. 10mm x 40mm Flange (2) |
| 6. Tensioner 89200B (1) | 13. 10mm Flange Nut (2) |
| 7. 10mm x 75mm (1) | 14. 1255-0090 Slide Bushing (2) |