



CW MILL EQUIPMENT CO., INC.
P.O. Box 246 • Sabetha, Kansas 66534
(785) 284-3454 • FAX (785) 284-3601

FMK 260SD508-8
2008-10 Ford Truck F250-550
6.4L Diesel
W-WO/AC,WO/Dual Alt.

INSTALLATION NOTES

1. Using an 8mm socket or wrench, disconnect the negative battery cables first, then disconnect the positive cables and remove the battery hold downs. Remove both batteries from the vehicle. Remove the two bolts from the power steering reservoir and lift it from its cradle. Remove the four bolts from the top half of the fan shroud. (Do not try to remove the fan shroud at this time) To protect the coolers, cut two pieces of cardboard, one 24" X 24" and one 24" X 36". Slide the 24 X 36 inch piece between the A/C condenser and the transmission cooler, and the 24 X 24 inch piece between transmission cooler and the CAC (charge air cooler).
2. Using a 10mm socket or wrench, remove the two upper CAC bolts, the transmission cooler bolts and the hood latch bolts. Disconnect the horns, remove the bolt holding them to the radiator support and remove the horn and bracket assembly from the vehicle. Remove the plastic clips holding the hood latch cable to the radiator support. Remove the upper radiator support bolts and clamps from each side of the radiator. Using a 13mm socket or wrench, remove the three radiator support bolts from each side of the radiator support. While pushing the top of the radiator towards the cab, lift up on the radiator support and remove it from the vehicle. Using a 11mm deepwell socket, loosen the two right hand CAC tube clamps and remove the tube. Remove the top half of the fan shroud from the vehicle.
3. Disconnect the cooling fan clutch electrical connector. Unclip and position the fan wiring aside. Using a fan nut tool, remove the cooling fan and clutch. **IMPORTANT** (fan nut has lefthand threads). Gently pulling the radiator forward for clearance, lift the fan and clutch assembly from the vehicle. Use extreme care not to damage the radiator with the fan during removal. Using a 13mm socket, remove the two upper nuts and two lower bolts from the fan diffuser and remove it from the vehicle.
4. Remove the O.E. 8-groove serpentine belt and tensioner. Release the tension on the A/C belt and remove the A/C tensioner. The A/C belt can be left on the truck. Remove the two flat idlers from the engine. Remove the two nuts and two bolts holding the alternator bracket to the engine. Slide the bracket forward on the studs to gain access to the alternator wiring. Disconnect the alternator wires and remove the alternator and bracket assembly from the engine.
5. With a suitable tool, remove a portion of the righthand side battery box as show in the illustration. This is done to gain clearance to the alternator. Remove the alternator from the alternator bracket. If equipped with a heavy duty alternator, the front valve cover bolt will need to have the threaded portion cut from the top of the bolt for clearance.

6. Install the alternator onto the new bracket reusing the O.E. bolts. Install the A/C compressor onto the bracket using bolts (4,5), slide bushings (6), and nuts (6). Install the bracket assembly onto the engine reusing the O.E. studs. Connect the alternator wires before sliding the bracket all the way back. Secure the bracket reusing the O.E. bolts and nuts. Torque nuts and bolts to 40-45 ft-lbs.
7. Install the O.E. A/C tensioner and belt onto the new bracket with the O.E. bolt. Install the O.E. idler with the washer on it onto the engine at its original location. Install the the drive pulley (1) onto the engine dampner using bolts (2) and torque them to 45-50 ft-lbs.
8. Install tensioner (8) onto the bracket in the upper location using bolt (9). Install the O.E. belt as shown in the diagram. Install the auxilary belt tensioner (10) using bolt (11). Install aux. A.C. belt (12). Using a suitable tool, remove the fins from the diffuser that comes in contact with the aux. A.C. tensioner and belt.
9. Replace the fan diffuser and fan. Fan nut gets torqued to 96 lb-ft. Connect the fan clutch wire. Replace the fan shroud. Install the CAC tube and torque the clamps to 11 ft-lbs. Replace the radiator core support and torque the bolts to 46 ft-lbs. Replace the radiator support clamps. Replace the transmission cooler and remove the cardboard from the vehicle. Replace the hood latch, use the washer marks on the latch to properly align the hood latch. Note: The hood latch bolts have serrated washers on them. Replace the powersteering resevoir. Install and connect the batteries.

NOTE: Check all wires, hoses, etc. that may have been disturbed during assembly to ensure they donot come in connect with any hot or moving parts.

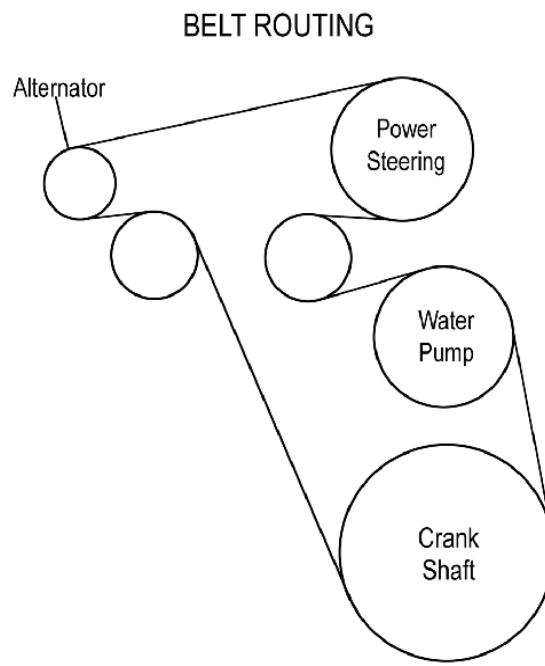

FMK 260SD508-8

2008-10 Ford Truck F250-550

6.4L Diesel

W-WO/AC,WO/Dual Alt.

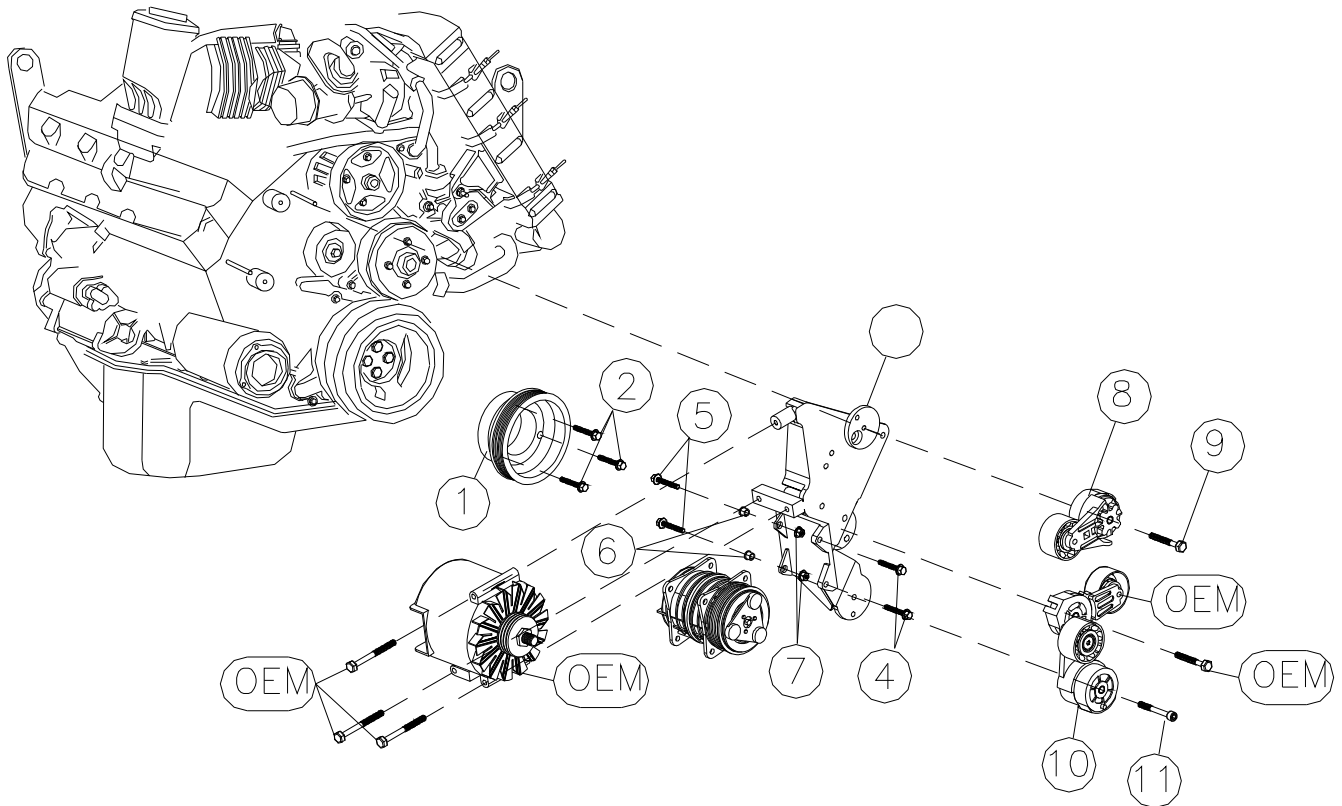

PARTS LIST

- | | | | |
|----|----------------------------|-----|------------------------|
| 1. | FPC2608(1) | 7. | 10mm Flange Nut(2) |
| 2. | 10mm x 50mm Bolts (3) | 8. | 89442(1) |
| 3. | FMP260SD508-8 | 9. | 10mm x 80mm Flange (1) |
| 4. | 10mm x 30mm Flange Bolt(2) | 10. | 89450(1) |
| 5. | 10mm x 40mm Flange (2) | 11. | 10mm x 60mm SHCS (1) |
| 6. | Slide Bushing (2) | 12. | 5080525 |

