



CW MILL EQUIPMENT CO., INC.
P.O. Box 246 • Sabetha, Kansas 66534
(785) 284-3454 • FAX (785) 284-3601

FMK47SD508-I6M

2013-2015 Ford F-650 6.8L
3 Valve Triton W-A/C

INSTALLATION NOTES

1. Disconnect the negative battery cable. Remove the OEM belt and idler at location "A". Remove the nut, radio noise suppressor and stud at location "B", and the bolt at location "C". Remove the bolts at locations "D" & "E". Install brace (2) with bolts (3) and flatwashers (4) at that location. On 2009 and newer models the O.E.M. alternator brace will need to be removed and trimmed according to the modifications sheet and spacers (18) will need to be installed. Radio noise suppressor can be installed at location "D". ***DO NOT TIGHTEN UNTIL MAIN BRACKET (1) IS TIGHTENED.***
2. Reroute the wiring harness so bracket (1) can be installed without damaging the wires. Install bracket (1) at location "B" with the bolt (6) and LW's (7), and location "C" with bolt (5) & lockwasher (7). Torque both bolts to 25 ft./lbs.. Install bolt (8) thru bracket (1), and into brace (2). Tighten bolts (8) and (3) evenly, then torque bolt (8) to 30 ft./lbs., and bolts (3) to 10 ft. lbs.. Install the OEM idler back to it's original location.
3. Install the aux. A.C. with bolts (13,16), nuts (14), and slide bushings (15). Install the belt according to the belt diagram, then install idler (10) in the lowest hole possible. *Note: It may be necessary to trim the plastic nipple or resonator from the air intake.* Connect the negative battery cable. Run the engine and check for proper belt tracking and clearances.

Note: Check all engine compartment hoses and electrical wiring that may have been disturbed or rerouted during kit installation to be sure that hoses are not kinked, that they do not touch any high temperature items, and that they do not interfere with any linkage components.

FMK47SD508-I6M

2013-2015 Ford F-650 6.8L

3-Valve Triton W-A/C

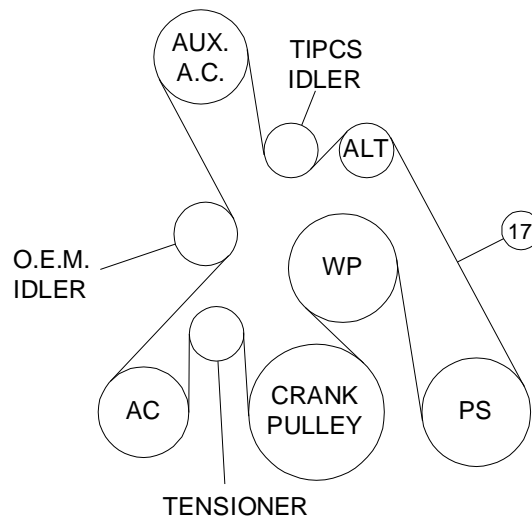
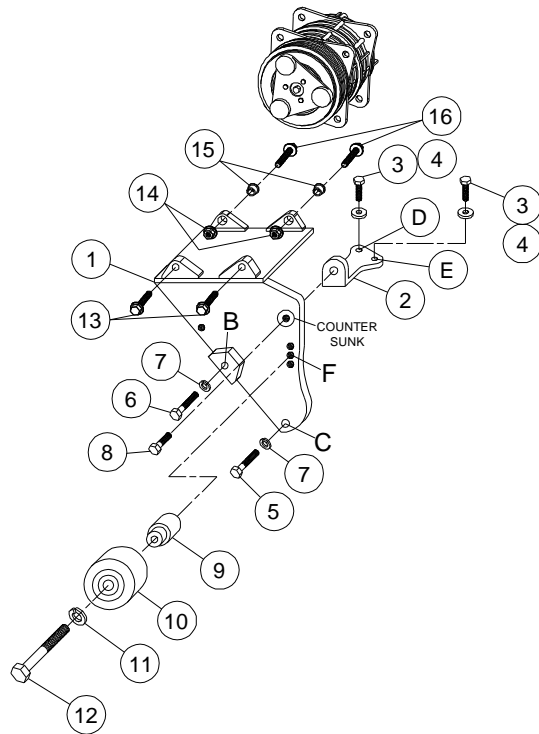
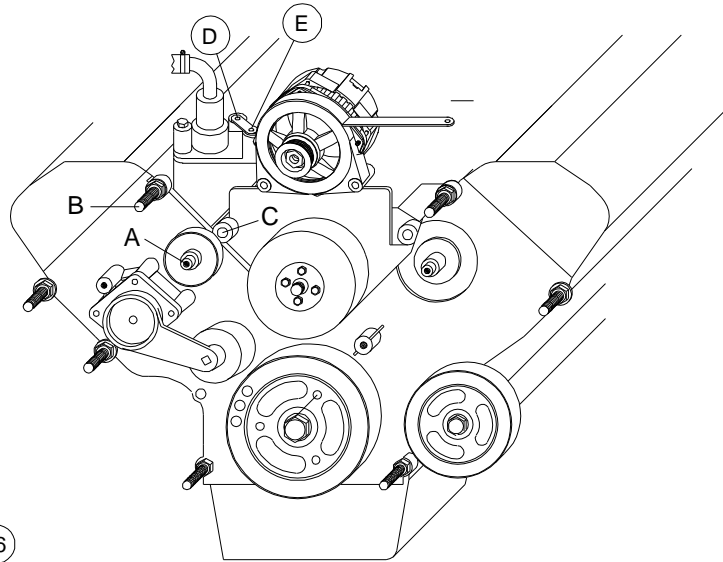

PARTS LIST

- | | |
|------------------------------|---------------------------------|
| 1. FMP 47SD508-I6 (1) | 10. 89007 Dayco (1) |
| 2. FMB 471-I6 (1) | 11. 12mm FW (1) |
| 3. 6mm x 25mm Bolt (2) | 12. 12mm x 45mm Bolt (1) |
| 4. 6mm FW (2) | 13. 10mm x 30mm Flange Bolt (2) |
| 5. 8mm x 60mm Bolt (1) | 14. 10mm Flange Nut (2) |
| 6. 8mm x 70mm (1) | 15. 1255-0090 Slide Bushing (2) |
| 7. 8mm LW (2) | 16. 10mm x 40mm Flange Bolt (2) |
| 8. 10mm x 20 Flange Bolt (1) | 17. 5061380 Dayco Belt (1) |
| 9. FMB 472-I6 (1) | 18. SP64-.1875 (2) |

MODIFICATIONS SHEET

6.8L TRITON
CUT HERE

6.8L TRITON
CUT HERE

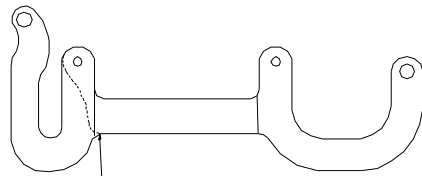
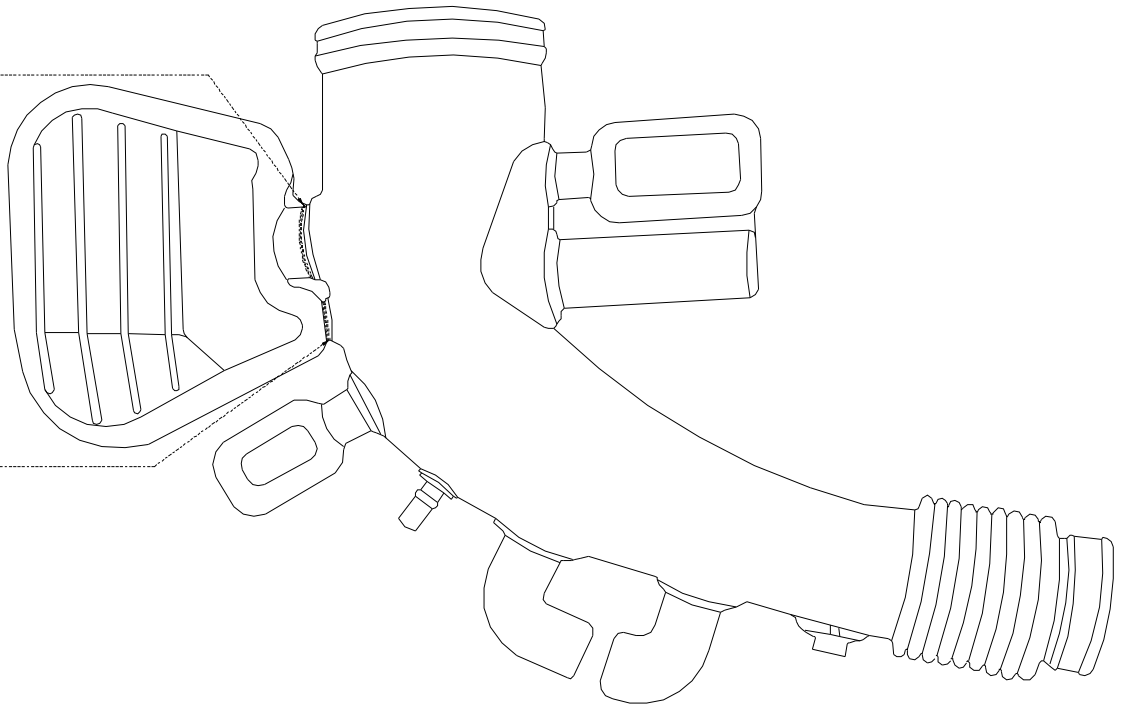

CUT ALONG LINE

FMB471-16

INSERT .188" SHIMS
ITEM #18

