



CW MILL EQUIPMENT CO., INC.
P.O. Box 246 • Sabetha, Kansas 66534
(785) 284-3454 • FAX (785) 284-3601

FMK 84SD508-8
2004-07 Ford F650 & F750
Diesel VT 365
W-W/O AC
W/O Air Compressor

INSTALLATION NOTES

1. Install drive pulley (1) onto harmonic balancer using bolts (2) and lockwashers (3). Torque bolts to 40 ft.lbs..
2. Install bracket (4) on the front of the driver side head at locations "A", "B", and "C" with bolts (5) and lockwashers (3). Torque bolts to 40 ft.lbs..
3. Install aux. A.C. compressor onto the bracket with bolts (10,11), nuts (12) and slide bushings (13). Install tensioner (6) with bolt (7). Install belt (8) as shown in diagram.
4. Run engine and check for proper belt tracking and clearances.

FMK 84SD508-8

2004-07 Ford F650 & F750

Diesel VT 365

W-W/O AC

W/O Air Compressor

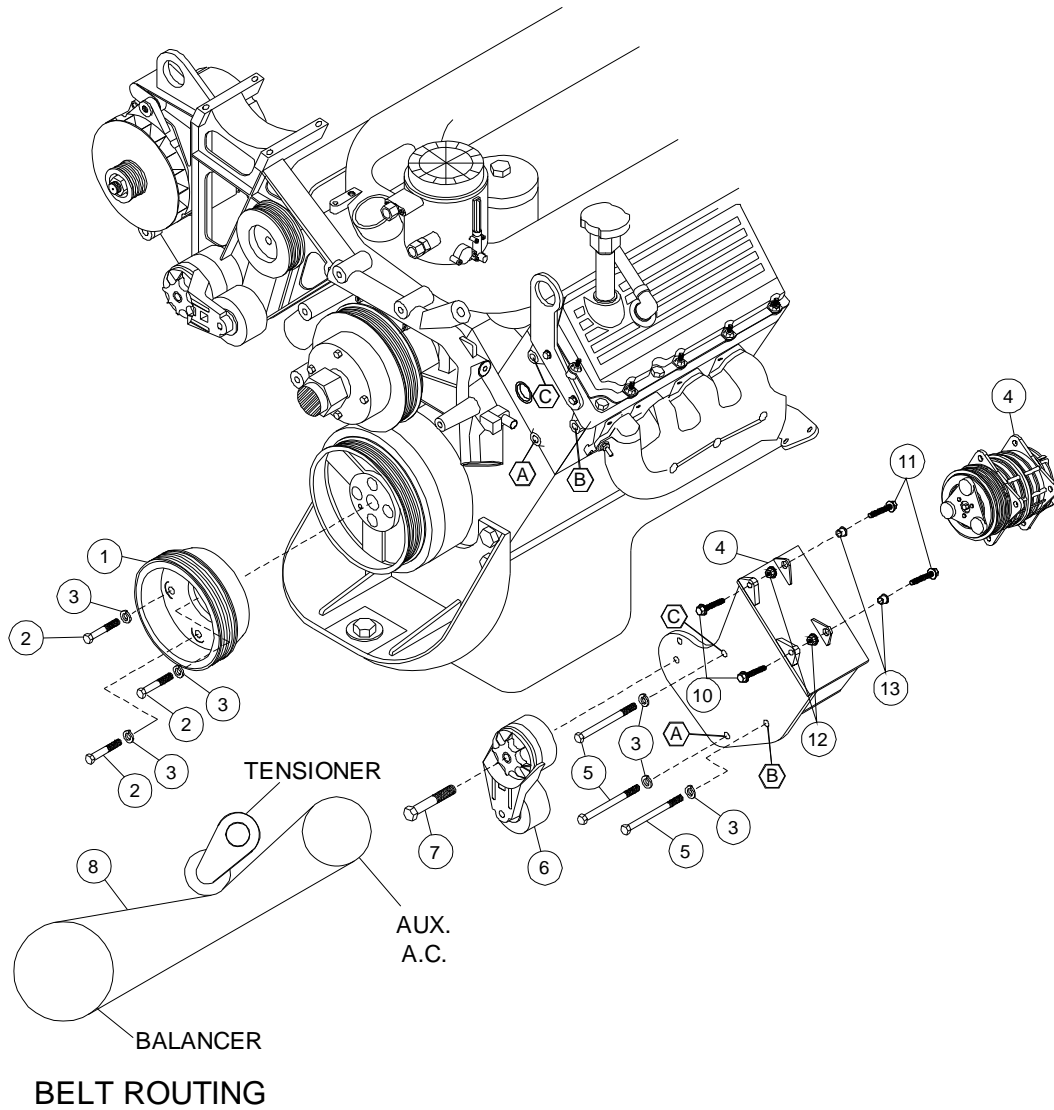

PARTSLIST

- | | |
|-------------------------|--------------------------------------|
| 1. FPC 688 (1) | 8. Dayco 5080620 (1) |
| 2. 10mm x 30mm (3) | 9. A.C. Compressor (Sold Separately) |
| 3. 10mm LW (6) | 10. 10mm x 30mm Flange (2) |
| 4. IMP 63SD508-8 (1) | 11. 10mm x 40mm Flange (2) |
| 5. 10mm x 150mm (3) | 12. 10mm Flange Nut (2) |
| 6. Tensioner 89200B (1) | 13. 1255-0090 (2) |
| 7. 10mm x 75mm (1) | |