



CW MILL EQUIPMENT CO., INC.
P.O. Box 246 • Sabetha, Kansas 66534
(785) 284-3454 • FAX (785) 284-3601

CMK 46 -2 Belts
1996-00 CHEVY 7.4L VORTEC
C&K-2500,3500,HD
454 W-WO/AC,
WO/A.I.R.,(K19)
(Serpentine)

INSTALLATION NOTES

1. Disconnect battery terminal. Remove serpentine belt and tensioner. Remove air filter assembly. **IMPORTANT:** Mark fan flange to water pump pulley for proper re-installation. Remove fan and shroud.
2. Remove crankshaft pulley, install O.E.M. crankshaft pulley on pump drive pulley (1) to check fit. **IMPORTANT:** Due to variations in O.E.M. pulley make sure both pulleys fully seat together. Install drive pulley (1) with provided bolts and lockwashers.
CAUTION: Be sure bolts have the same threads as O.E.M. bolts removed, discard O.E.M. center flatwasher.
3. Remove battery ground wire from lower bolt hole on front of the engine at location "A". Install set screw (15) at location "A". Remove bolts at location "C & D" on alternator bracket. Install bracket (10) at location "A & B" with bolts, washer and nuts (16,7,18). Locate holes "E & F" on the water pump. Use bolts and washers (22 & 24). At location "C & D" use spacers (12) bolts (14) and washers (17). At location "G" use spacer (13), bolt (21) and washer (24). Tighten all bolts at all locations.
4. Mount clutch pump (32) to pump plate (11). Make sure clutch pulley is aligned with drive pulley (1). Tighten pump bolts securely. Install pump drive belts (31), adjust pump plate (11) for proper belt tension, tighten bolts (19 & 20). Connect battery ground wires.
5. Remove fan studs and replace with provided studs (7). Install fan spacer (6), fan and shroud. **IMPORTANT:** Align marks from step 1. Tighten securely.
6. Secure heater hoses out of way using ties (30) provided.
WITH/AC: Secure AC line to fan shroud with clamp (29) provided.
7. **CAUTION:** Check all engine compartment wiring, vacuum and hoses that may have been disturbed or re-routed during kit installation. Be sure hoses are not kinked, do not contact any high temperature item, or moving components.

NOTE: Visually make certain that there is adequate clearance between fan and drive pulley and also between fan and radiator. It may be necessary to use a longer spacer for pulley or radiator clearance.

CMK 46 -2 Belts

1996-00 CHEVY 7.4L VORTEC

454 W-WO/AC

WO/A.I.R. (K19)

(SERPENTINE)

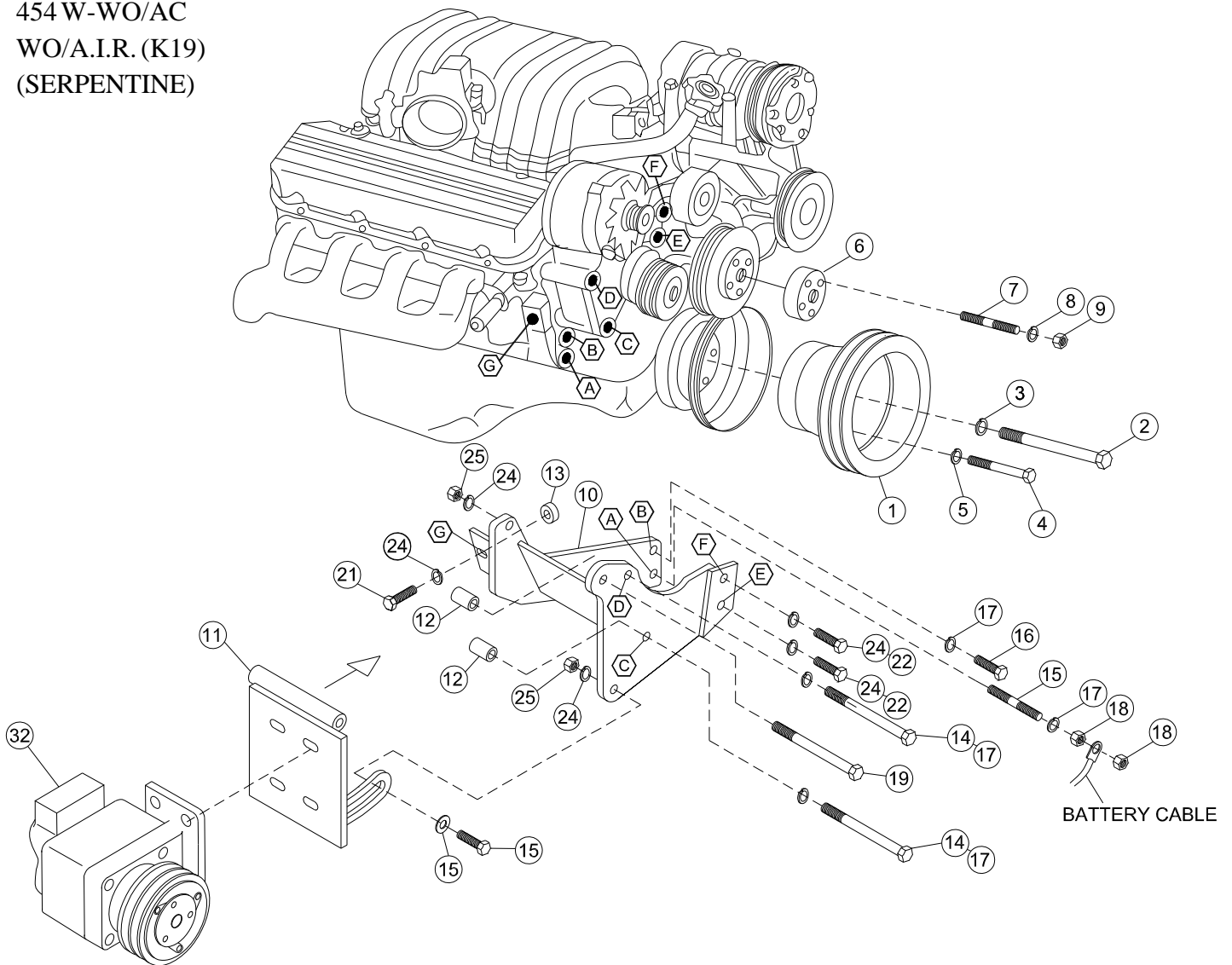

PARTS LIST

- | | | |
|----------------------------|---------------------------------|------------------------------|
| 1. CPC 442 (1) | 12. SP88-1.375 (2) | 23. 3/8 FW (1) |
| 2. 1/2 x 3 NF GR. 8 (1) | 13. SP88-.375 (1) | 24. 3/8 LW (5) |
| 3. 1/2 LW (1) | 14. 7/16 x 6 NC (2) | 25. 3/8 NC (2) |
| 4. 3/8 x 3 NC,NF GR. 8 (3) | 15. 7/16 x 2 1/2" Set Screw (1) | 26. 1/4 x 3/4 NC (1) |
| 5. 3/8 LW (3) | 16. 7/16 x 1 NC (1) | 27. 1/4 LW (1) |
| 6. FSO 516 (1) | 17. 7/16 LW (4) | 28. 1/4 NC (1) |
| 7. 8mm x 45mm 1.25 ST (4) | 18. 7/16 NC (2) | 29. #14 7/8" Adel Clamp (1) |
| 8. 8mm LW (4) | 19. 3/8 x 5 1/2 NC (1) | 30. Wire Ties (2) |
| 9. 8mm 1.25 (4) | 20. 3/8 x 1 1/2 NC (1) | 31. Belts (Not Shown) |
| 10. CMB460 (1) | 21. 3/8 x 1 1/4 NC (1) | #1 Pump-Dayco AX-51 (2) |
| 11. CMP 46(0-4) (1) | 22. 3/8 x 1 NC (2) | #2 & #4 Pump-Dayco AX-50 (2) |
| | | 32. Clutch Pump Assembly (1) |
| | | (Sold Separately) |

Note: With 7" Clutch #2 & #4 AX-52.