



CW MILL EQUIPMENT CO., INC.  
P.O. Box 246 • Sabetha, Kansas 66534  
(785) 284-3454 • FAX (785) 284-3601

**CMK 86-I6 Belts**  
2003-2009 4500-5500  
6.6L Duramax Diesel  
W/A/C, W/O Dual Alternators

## INSTALLATION NOTES

---

1. Disconnect the positive battery cables. Remove the drivers side inner fender. Remove the O.E.M. accessory drive belt. Remove the two 12mm bolts holding the P/S pump to the A/C bracket and lay the pump aside. (DO NOT DISCONNECT ANY HOSES) Remove the bolt holding the dipstick tube to the A/C bracket but do not move the dipstick tube. Remove the bolt at location A.
2. Install bracket (1) onto the A/C bracket with bolts (3, 5, 6,) and LW's (4). Tighten all bolts lightly, then torque bolts (3) to 60 ft-lbs, bolt (6) to 40 ft-lbs, and bolt (5) to 20 ft-lbs. Install bracket (2) with bolts (7) and (8). Tighten bolts lightly, then torque them to 40 ft-lbs.
3. Install the power steering pump onto the new bracket reusing the O.E.M. bolts. Loosen the jam nut on the power steering pump hose and pivot the hose to gain adequate clearance to the steering shaft. With the hose repositioned, lock the jam nut securely. Install the pump onto the pump plate with the bolts provided. Install the pump and plate assembly onto the bracket with nuts (10) and bolts (11). Align the clutch with the A/C and P/S pulleys then tighten the plate securely. Perfect alignment is crucial for proper belt tracking and belt life, so use a straight edge and extra time when aligning the pump.
4. Install the dual bearing idler (13) with bolt (12) and bushing (14) at location (B). Install the new belt according to the belt diagram, then depress the tensioner and install idler (15) into the lowest possible hole, tighten the bolt securely then release the tensioner. Due to limited space, this procedure might require two people. Install the inner fender and connect the battery cables.
5. Check all wires, hoses, etc. for proper clearance to any hot or moving parts. Run the engine and check for proper belt tracking. Adjust if necessary.

**NOTE: This kit will work W/O A/C, but a shorter belt will be required**

**CMK 86 -I6 Belts**  
**2003-2009 4500-5500**  
**6.6L Durimax Diesel**  
**W/ AC, W/O Dual Alt.**

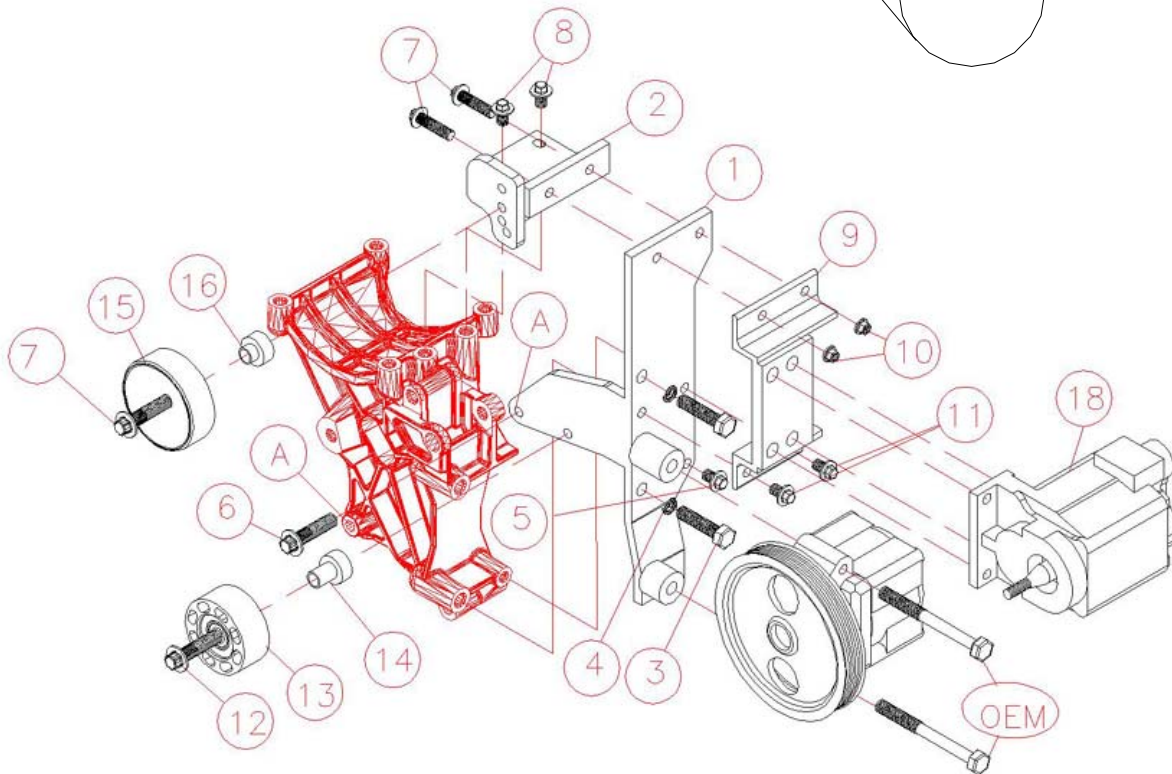
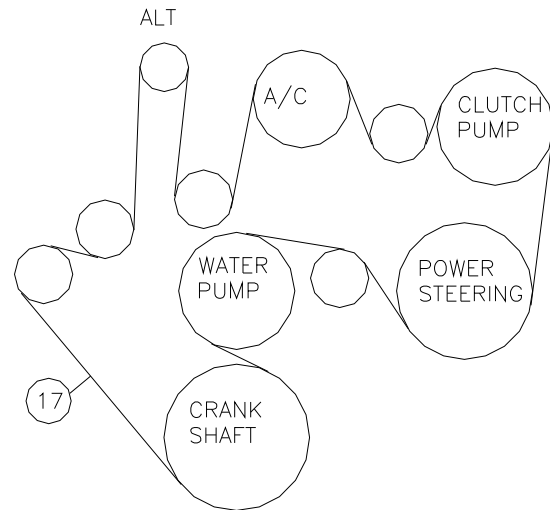

**PARTS LIST**

- |    |                             |     |                               |
|----|-----------------------------|-----|-------------------------------|
| 1. | CMB860-I6 (1)               | 10. | 10mm Flange Nut (2)           |
| 2. | CMB861-I6 (1)               | 11. | 10mm x 20mm Flange Bolt (2)   |
| 3. | 12mm x 35mm Bolt (2)        | 12. | 12mm x 45mm Flange Bolt (1)   |
| 4. | 12mm LW (2)                 | 13. | 89058 Dayco Tensioner (1)     |
| 5. | 8mm x 25mm Flange Bolt (1)  | 14. | CMB862-I6 Bushing             |
| 6. | 10mm x 90mm Bolt (1)        | 15. | 89006 Dayco Idler (1)         |
| 7. | 10mm x 40mm Flange Bolt (3) | 16. | CMB863-I6 Bushing (1)         |
| 8. | 10mm x 30mm Flange Bolt (2) | 17. | 5061360 Dayco Belt (1)        |
| 9. | CMP 86(0-4) (1)             | 18. | Clutch Pump (Sold Separately) |