



CW MILL EQUIPMENT CO., INC.
P.O. Box 246 • Sabetha, Kansas 66534
(785) 284-3454 • FAX (785) 284-3601

VCK 35 -2 Belts

1993-96 CHEVY VAN
305,350 G-1500,2500,3500
W-WO/AC, A.I.R.
(Serpentine)

NOTE: MUST USE SIDE PORTED PUMP.

INSTALLATION NOTES

1. Disconnect battery terminal. Remove belt and ram air tube. Mark diameter of O.E.M. pulley on crankshaft, onto bottom of fan shroud. It is necessary to trim approx. 1" from shroud, between marks to inner rib on shroud, for drive pulley (1) clearance.
2. Mark location of fan on water pump pulley. Remove fan and shroud. Trim shroud as marked. Remove braces between radiator and frame.
3. Remove bolts and washers from pulley on front of crankshaft. Install aluminum adapter (2) and drive pulley (1) with provided bolts. **CAUTION:** Be sure bolts have same thread as O.E.M. bolts removed.
4. Remove fan studs and replace with provided studs (9). Install fan spacer (8), insert fan and shroud, secure shroud. Locate fan to pulley as marked and tighten securely with lockwashers (10) and nuts (11) provided.
5. Remove bolt at location C. Install bracket (12) and brace (13) with bolts (17,19 & 20), install battery cable at location C, tighten securely.
6. Install jack bolts (25) and clutch pump to pump plate (15), do not tighten bolts. Bolt pump plate to bracket (12) with bolts (16,18 & 21) and slotted bracket (14).
7. Align clutch pulley to drive pulley (1). Tighten pump bolts. Install pump drive belts (26). Using jack bolt, adjust pump plate for proper belt tension.
8. Slightly bend transmission cooler lines away from bracket, if necessary. Install ram air tube. Connect battery terminal.

NOTE: It is necessary to use a side ported pump as clearance to the crossmember is minimal. Although it is seldom necessary, should the lip on front of crossmember need trimmed for pump clearance, leave large radius in corners of cut.

NOTE: It is recommended that a skid plate be installed to protect clutch pump from road debris and the elements.

NOTE: Visually make certain that there is adequate clearance between fan and drive pulley, and also fan to radiator. It may be necessary to use a longer spacer for pulley clearance. If there is little clearance to the radiator, check with Chevy dealer to insure that it will not flex into the radiator before operating. Provide adequate clearance between fan and radiator before operating.

VCK 35 -2 Belts

1993-96CHEVY VAN

305,350 W-WO/AC, A.I.R.

(Serpentine)

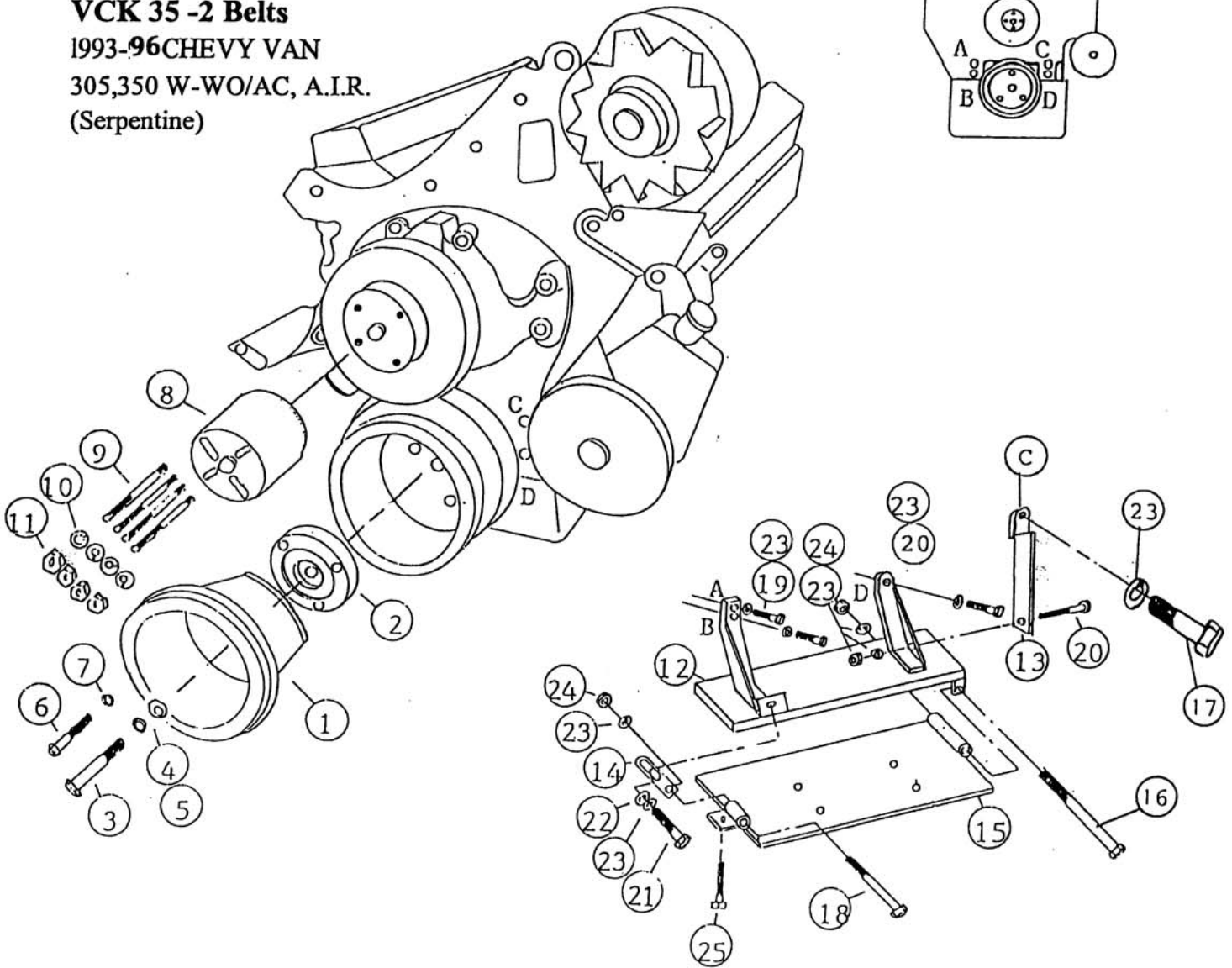

PARTS LIST

- 1. CPC 312 (1)
- 2. CPA 352 (1)
- 3. 7/16 X 4 1/2 NF (1)
- 4. 7/16 LW (1)
- 5. O.E.M.
- 6. 3/8 X 3 NF GR. 8 (3)
- 7. 3/8 LW (3)
- 8. FSO 512 (1)
- 9. 8mm X 75mm ST (4)
- 10. 8mm LW (4)
- 11. 8mm 1.25 (4)
- 12. VCB 351 (1)
- 13. VCB 352 (1)

- 14. VCB 343 (1)
- 15. VCP 34(0-4) (1)
- 16. 3/8 X 4 1/2 NC (1)
- 17. 3/8 X 4 NC (1)
- 18. 3/8 X 2 1/2 NC (1)
- 19. 3/8 X 1 3/4 NC (2)
- 20. 3/8 X 1 1/2 NC (2)
- 21. 3/8 X 1 1/4 NC (1)
- 22. 3/8 FW (1)
- 23. 3/8 LW (8)
- 24. 3/8 NC (3)
- 25. 3/8 X 3 1/2 SHSS
- 26. AX-37 (2)(Not Shown)(#4-AX-36)
- 27. Clutch Pump Assembly (1)
(Sold Separately)

NOTE: Must use side ported pump.