



CMK38J180-I6

99-2010 Silverado/Sierra

99-2014 Tahoe/Yukon/Suburban

4.8, 5.3, 6.0

W-WO/AC

INSTALLATION NOTES

1. Disconnect negative battery cable. Remove the air intake duct. The fan and fan shroud may be removed to make installation slightly easier, but is not necessary. Remove the O.E.M. belt. Remove the metal bracket holding the hot wire junction block from the side of the alternator bracket and from the junction block (discard). Remove the three bolts at locations "A, B & C".
2. Position bracket (1) over the front of the O.E.M. alternator bracket and install bolts (6) with lockwashers (12) at locations "A, B & C". Tighten bolts securely. Install brace (2) with bolts (8 & 10), flatwashers (11) and bushing (13) to the back of bracket (1) and to the engine at location "D". Tighten bolts evenly and securely.
3. Install the alternator onto the bracket with bolt (14), lockwasher (16) and nut (17). **DO NOT TIGHTEN.** Remove the O.E.M. alternator bolt that's closest to the fender. Install brace (4) with bolt (7) and lockwasher (12) into the O.E.M. alternator and bolt (15) with lockwasher (16) onto the add on alternator. **TIGHTEN ALTERNATOR BOLTS.**
4. Install the idler (5) with bolt (9), lockwasher (12), flatwasher (11) and bushing (3) into the bottom tapped hole on the front of the bracket. If the truck has a 105 amp alternator and the top hole if the truck is equipped with a 130 amp alternator. Install the new belt (19) onto the engine as shown on the illustration. Make sure the tensioner has adequate travel left once the belt is on. Replace the fan and fan shroud if removed. Replace the air intake duct and connect the battery. Secure any hoses or wires that may have been moved during installation. Run the engine and check for proper belt tracking.

CMK 38 J-180-I6

99-2010 Silverado/Sierra

99-2014 Tahoe/Yuon/Suburban

4.8, 5.3, 6.0

W-WO/AC

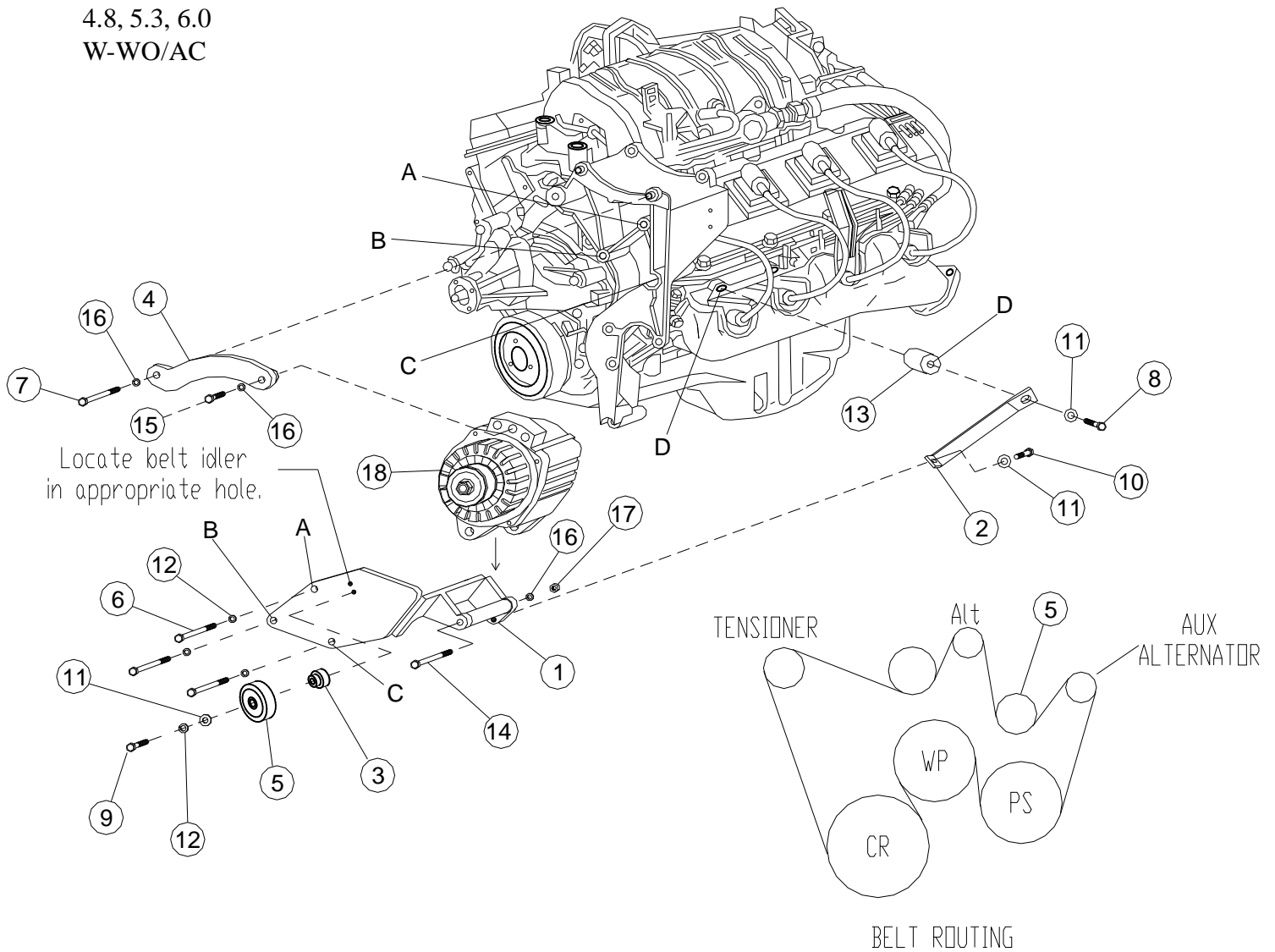

PARTS LIST

- | | |
|----------------------|----------------------------------------|
| 1. CMB 380-J-180 (1) | 10. 10mm x 25mm (1) |
| 2. CMB 381-J-180 (1) | 11. 10mm FW (3) |
| 3. CMB 382 (1) | 12. 10mm LW (5) |
| 4. CMB 383-J-180 (1) | 13. 1" x 1.70 Bushing (1) |
| 5. 89007 Dayco (1) | 14. 1/2 x 6 NC (1) |
| 6. 10mm x 140mm (3) | 15. 1/2 x 2 NC (1) |
| 7. 10mm x 100mm (1) | 16. 1/2 LW (2) |
| 8. 10mm x 65mm (1) | 17. 1/2 NC (1) |
| 9. 10mm x 50mm (1) | 18. Alternator (Sold Separately) |
| | 19. 5061130 Dayco belt (1) (Not Shown) |



CW MILL EQUIPMENT CO., INC.
P.O. Box 246 • Sabetha, Kansas 66534
(785) 284-3454 • FAX (785) 284-3601

BULLETIN

CMK 38 92V-I6

Chevy/GMC 4.8,5.3,6.0 W-WO/AC

All 4.8, 5.3, and 6.0 litre engines will require the removal of aluminum from the O.E.M. alternator bracket in order for the alternator to fit properly. The illustration shows the area that needs to be removed.

