

INSTALLATION NOTES

1. Disconnect negative battery cable. Remove the top half of the fan shroud and the fan. (*Fan nut is right hand threads*). It's not necessary to remove the fan and fan shroud, but makes installation easier. Remove the air cleaner duct and the O.E.M. belt.
2. Remove the three bolts holding the alternator bracket to the engine. Install the aux. alternator bracket (1) using those three hole locations on the alternator bracket with bolts (8) and lock-washers (7). Tighten bolts securely. Install brace (2) using bolt (9) and bushing (3) at the engine, and bolt (10) at the back of the aux. alternator bracket (1). Tighten bolts (9) and (10) evenly so the brace does not pull the main bracket when tightened.
3. Install aux. alternator onto the main bracket (1) with bolts (12) and slide bushings (13). Install idler (5) with bolt (6) and bushing (4) into the tapped hole located at the bottom of the bracket (1). Install the belt, then load the tensioner and install the other idler (5) into the lowest possible hole it will fit into on the front of the main bracket using bolt (6) and bushing (4).
4. Replace the fan and top half of the fan shroud if removed. Replace the air duct. Connect battery. Run the engine and check for proper belt tracking. Adjust if necessary.
5. If wires from the ECM run close to the belt or alternator pulley, use 1/4 bolts, washers, spacers and nut to relocate the ECM to the fan shroud.

NOTE: Check all engine compartment hoses and electrical wiring that may have been disturbed or rerouted during kit installation to be sure that hoses are not kinked, that they do not touch any high temperature items, and that they do not interfere with any linkage components.

CMK 3992V-I6
2011-2013 C&K 1500
2011-2016 C&K 2500-3500
4.8,5.3,6.0
W-WO/AC

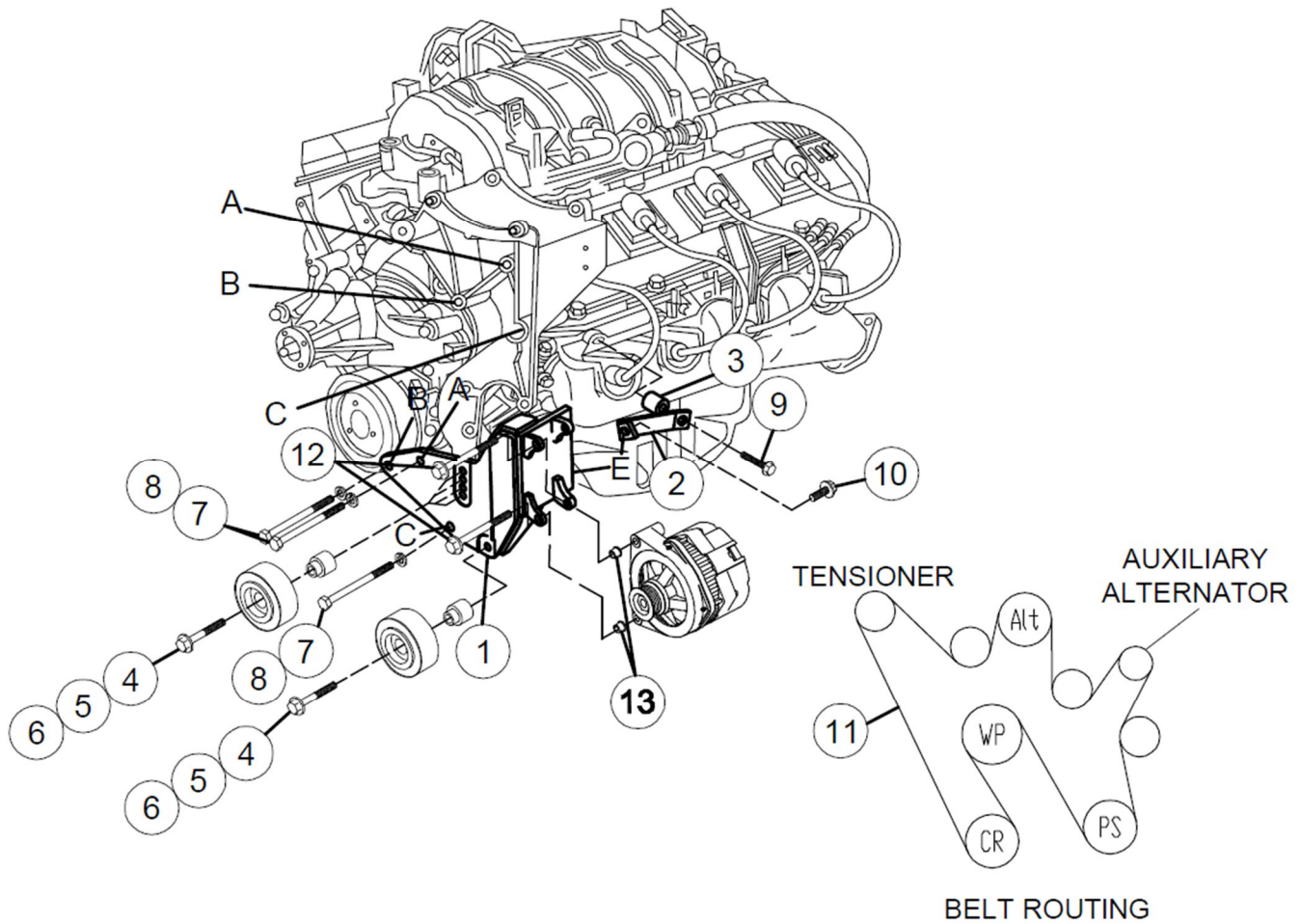

PARTS LIST

- | | |
|---|-------------------------------------|
| 1. CMP39SD508-I6 (1) | 10. 10mm x 20mm Flange Bolt (1) |
| 2. CMB391 (1) | 11. Belt Dayco 5061150 (1) |
| 3. SP100-1.200 (1) | 12. 10mm x 80mm Flange (2) |
| <i>(TIPKSC-39 Includes one of each items 4-6)</i> | 13. 1255-0090 Slide Bushing (2) |
| 4. CMB 3867 (2) | <u>ITEMS 14-17 NOT SHOWN</u> |
| 5. 89007 (2) | 14. 1/4 x 2 NC Bolt (4) |
| 6. 10mm x 40mm Flange Bolt (2) | 15. 1/4 Flat washer (4) |
| 7. 10mm Lock washer (3) | 16. 1/4 Nylock Nut (4) |
| 8. 10mm x 140mm 1.5 (3) | 17. SP64-0.500 Spacer (4) |
| 9. 10mm x 50mm Flange Bolt (1) | |