

INSTALLATION NOTES

Be sure to read and understand all available information including but not limited to instructions, warnings, sale terms, and warranties for the vehicle and all system components prior to attempting installation.

Disconnect negative battery cable. Disconnect wiring from alternator. Remove the drive belt. Remove the radiator fan and set inside the shroud. **NOTE: Fan has right hand threads.** Remove alternator, alternator bracket engine lifting lug. Engine lifting lug will not be reinstalled. Remove the air intake tube to give more room during install. Remove the tensioner and the power steering pump. The hoses do not need to be removed from the power steering pump. It can be set aside in the engine compartment. Remove the bracket from the engine that the power steering pump was bolted to.

Install new bracket (1) as shown using bolts (2-7). Install the OEM alternator onto the bottom of the bracket reusing the O.E.M. bolts. Install the power steering pump onto the bracket using bolts (3,8).

Install the auxiliary alternator and brace (17) with hardware (21-24). Install tensioner (9) using bolt (8). Install the 3" idler (11) with bushing (10) and bolt (12) onto the bracket into one of the three tapped holes. The idler will usually need to go in the top hole. Replace the 2 ½ stamped steel OEM idler that is located just below the upper radiator hose with the 2 ½ machined steel idler (14) using bushing (13) and bolt (15).

PARTS LIST

- | | |
|----------------------------|-------------------------------------|
| 1. VFMP36J180-I7 (1) | 14. IPCS-2.5 (1) |
| 2. 10mm x 50mm Flange (2) | 15. 10mm x 60mm Flange (1) |
| 3. 8mm x 80mm Flange (2) | 16. 1255-0090 Spit Bushing (2) |
| 4. 8mm x 60mm Flange (1) | 17. Alternator Brace (1) |
| 5. 8mm x 70mm Flange (2) | 18. 1/2 x 2 Bolt (1) |
| 6. 8mm x 25mm Flange (1) | 19. 1/2 LW (1) |
| 7. 8mm x 30mm Flange (1) | 20. 1/2 FW (1) |
| 8. 8mm x 50mm Flange (3) | 21. 6x35mm Flg Bolt (2) |
| 9. Dayco 89281 (1) | 22. 8mm Coupler Nut (1) |
| 10. CMB3867 (1) | 23. 1/2 x 6 Bolt (1) |
| 11. Dayco 89007 (1) | 24. 1/2 Nut (1) |
| 12. 10mm x 40mm Flange (1) | 25. 5071223 Belt (1) |
| 13. VFMB36-2 (1) | 26. VFK36 Wiring kit (Not shown)(1) |

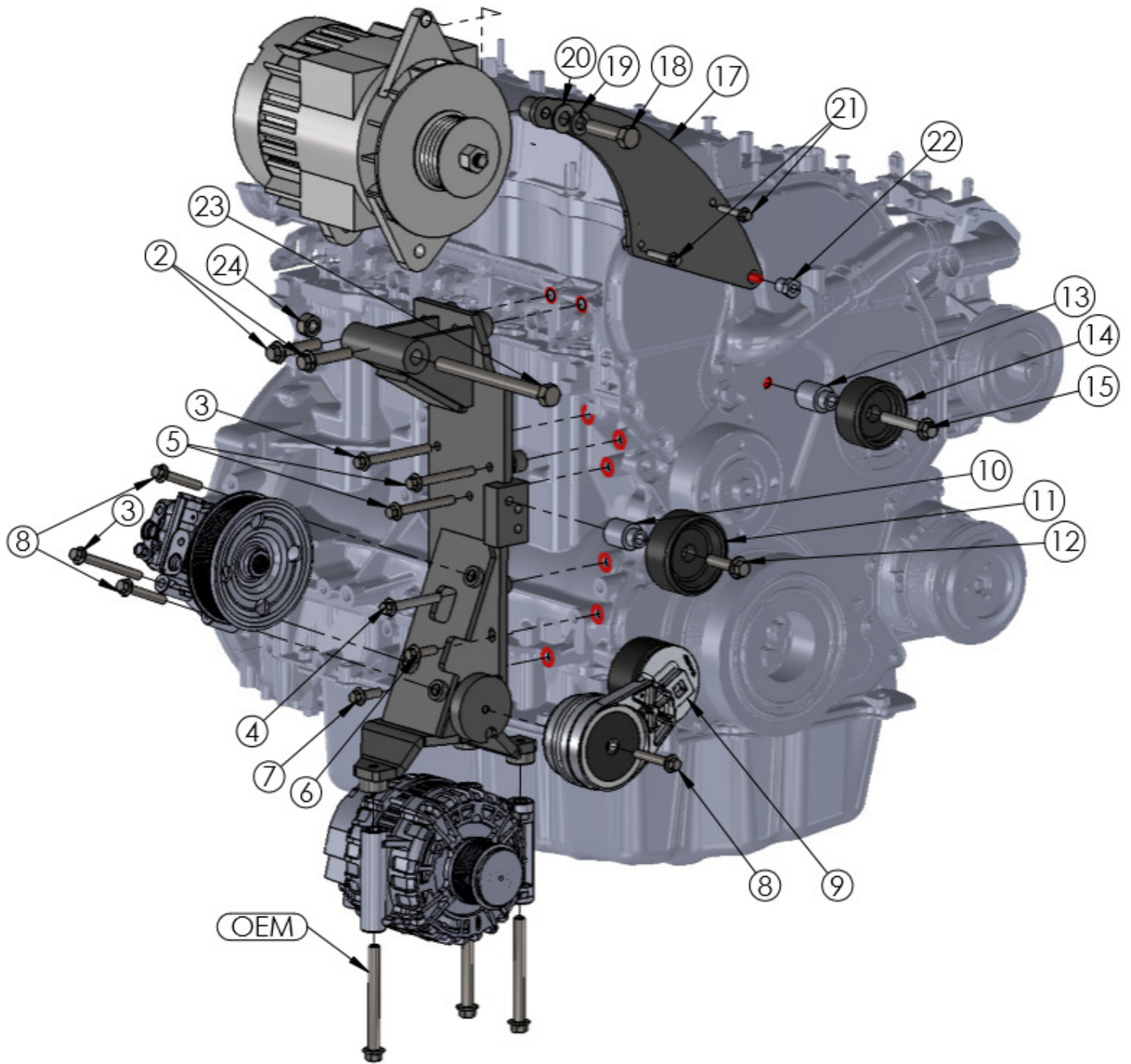

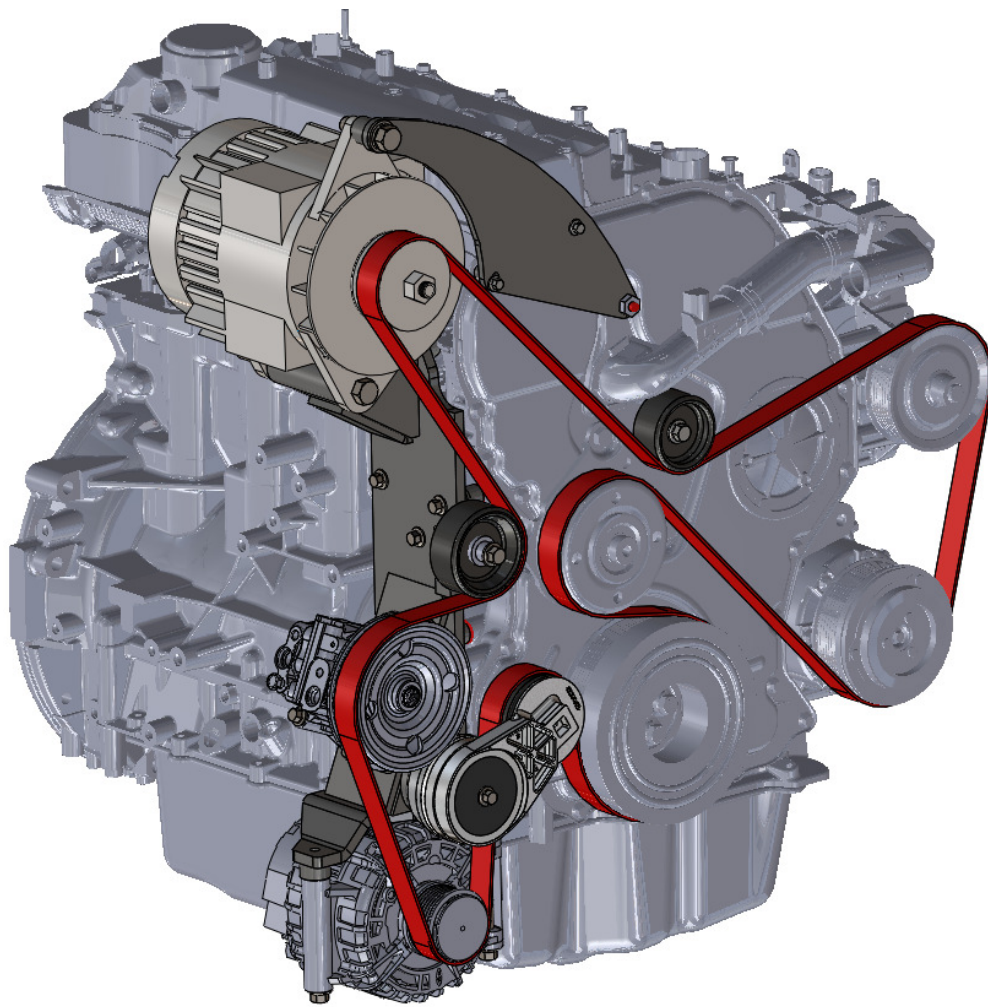

Install belt(25) according to the diagram above. Readjust idler if necessary. Check belt alignment.

Install the fan. Using the wire extension provided, splice into the alternator wiring by crimping and soldering connections and insulating using shrink sleeve. Connect main battery wire extension using the 8mm x 12mm flange bolt and nut. Connect the plug and power wire to the alternator. Install the air intake tube. Reconnect battery cable. Run engine, check for proper belt tracking. Be sure no wires or hose come in contact with any hot or moving parts.

Disclaimer: (1.) Due to the custom nature and variation of all add-on systems of this type, no complete system kits are offered by the manufacturer, and any group of parts marketed as a kit is limited to only the individually defined parts in that specific kit. The system designer's rotating accessory components are not included, offered, or fully known by the manufacturer. In addition to the absence of the rotating accessory system, other potential components such as additional clamps, brackets, wear liners, hardware, or other items that may be required by the system designer must be identified and supplied by the actual system designer. (2.) Due to vehicle manufacturer's assembly tolerances, production changes, and installation variances, it is the buyer's responsibility to insure adequate clearance for all components including space for and safe location of the fan, radiator, all lines, and wires. Check for possible movement, vibration, friction points, heat exposure and/or shifting of any and all components such as hoses, wires, and all other components including those that may otherwise be considered non-moving and/or unaffected by the installation (3.) The buyer is responsible for the entire installation of a mounting kit as the mounting kit is part of a custom process controlled by the buyer through their whole system design and directed installer as the installer evaluates, locates, routes, aligns, and tightens all components while determining if additional clamps, brackets, wear-liners, or other components may be required, beyond those included in the kit. Any additional items required, beyond those included in the kit, are to be provided at the expense of the buyer. (4.) the buyer is responsible for the development and communication of their whole system installation procedures, safety precautions, application, and use of the engine accessory mounting kit in their system, including efforts to maintain vehicle control and prevent pinch, wear, impact, and/or burn exposure on all hoses, wires, and other parts. (5.) The buyer is responsible for providing trained and experienced installation decision making with technical know-how to apply professional judgment that specifically applies to each individual installation. The buyers chosen installers must be qualified and experienced technicians that are familiar with the vehicle and accessory being mounted as well as the buyer's whole system design and installation procedures associated with the kit. (6.) The buyer is responsible for determining and achieving compliance to all regulatory issues that apply to the use of all products. (7.) The manufacturer reserves the right to make changes and/or improvements to any product at any time with or without notice.