



CMK140A-I6

2020-2024 Chevrolet Silverado 2500HD-3500HD
2020-2024 GMC Sierra 2500HD-3500HD
6.6L V8 Gas w/-w/o A/C, w/o OEM Dual Alternators

Requires 6-Groove Clutch, SAE Two-Bolt "A" Flange Pump
Recommended 1.75 in.³ or 8 gal. Pump w/ 12hp Restriction
NOTE: Must use Rear Ported Pump

INSTALLATION NOTES

1. The buyer is responsible for providing trained and experienced installation decision making with technical know-how to apply professional judgment that specifically applies to each individual installation.
2. Be sure to read and understand all available information including but not limited to instructions, warnings, sale terms, and warranties for the vehicle and all system components prior to attempting installation.
3. Disconnect the negative battery cable. Remove the upper fan shroud, air filter tube, and air deflector. Remove the fan (fan has right-hand threads).
4. Remove the OEM belt. Remove the power steering pump bolts by going through the pulley (discard). Set aside the power steering pump. Remove the OEM power steering bracket. Save the bolts for reinstallation in the next step.
5. Remove the wire bracket, and cut the bracket as shown, reinstall.
6. Install studs (3) in the engine block at mounting location [A]. Install the main bracket (1) onto the engine block with the retained OEM power steering bracket bolts (2) at mounting location [B] and nuts (4) at mounting location [A]. Install the clutch pump assemblies according to the manufacturers' instructions with mounting hardware (15-18). Install the power steering pump using bolts (5) onto the main bracket (1). Place the small coolant hose behind pump reservoir.
7. Install the smooth idler assembly (6-9) onto the main bracket (1).
8. Install new belt (19). Route it according to the belt diagram. With the tensioner completely loaded, install the grooved idler pulley assembly (10-14) onto the main bracket (1) as far down on the slot as needed. Release the tensioner. Adjust the belt or other components as necessary.
9. Reinstall the fan, air deflector, air filter tubes, and fan shroud. It may be necessary to rotate the upper radiator hose slightly for clearance. Reconnect the negative battery cable.

CAUTION: Before starting the engine, check to make certain no wires, hoses, etc. that may have been disturbed during installation do not come in contact with any hot or moving parts. Properly refill any fluids that may have been drained. Check for leaks. Run the engine, check for proper belt tracking and clearance of any hoses, wires, etc. It is the installer's responsibility to correct/adjust any components, if necessary, before the vehicle is put into service.

CW Mill Equipment Co., Inc. Mounting Kit and Mounting Kit Component Disclaimer: (1.) Due to the custom nature and variation of all add-on systems of this type, no complete system kits are offered by the manufacturer, and any group of parts marketed as a kit is limited to only the individually defined parts in that specific kit. The system designer's rotating accessory components are not included, offered, or fully known by the manufacturer. In addition to the absence of the rotating accessory system, other potential components such as additional clamps, brackets, wear liners, hardware, or other items that may be required by the system designer must be identified and supplied by the actual system designer. (2.) Due to vehicle manufacturer's assembly tolerances, production changes, and installation variances, it is the buyer's responsibility to ensure adequate clearance for all components including space for and safe location of the fan, radiator, all lines, and wires. Check for possible movement, vibration, friction points, heat exposure and/or shifting of any and all components such as hoses, wires, and all other components including those that may otherwise be considered non-moving and/or unaffected by the installation (3.) The buyer is responsible for the entire installation of a mounting kit as the mounting kit is part of a custom process controlled by the buyer through their whole system design and directed installer as the installer evaluates, locates, routes, aligns, and tightens all components while determining if additional clamps, brackets, wear-liners, or other components may be required, beyond those included in the kit. Any additional items required, beyond those included in the kit, are to be provided at the expense of the buyer. (4.) The buyer is responsible for the development and communication of their whole system installation procedures, safety precautions, application, and use of the engine accessory mounting kit in their system, including efforts to maintain vehicle control and prevent pinch, wear, impact, and/or burn exposure on all hoses, wires, and other parts. (5.) The buyer is responsible for providing trained and experienced installation decision making with technical know-how to apply professional judgment that specifically applies to each individual installation. The buyers chosen installers must be qualified and experienced technicians that are familiar with the vehicle and accessory being mounted as well as the buyer's whole system design and installation procedures associated with the kit. (6.) The buyer is responsible for determining and achieving compliance to all regulatory issues that apply to the use of all products. (7.) The manufacturer reserves the right to make changes and/or improvements to any product at any time with or without notice.



CW Mill Equipment Co., Inc.
 14 Commerce Drive Sabetha, KS 66534
 Phone: (785) 284-3454
 Fax: (785) 284-3601
 Email: brackets@cwmill.com
 Website: www.cwkits.com

CMK140A-I6

2020-2024 Chevrolet Silverado 2500HD-3500HD
 2020-2024 GMC Sierra 2500HD-3500HD
 6.6L V8 Gas w/-w/o A/C, w/o OEM Dual Alternators

Requires 6-Groove Clutch, SAE Two-Bolt "A" Flange Pump
 Recommended 1.75 in.³ or 8 gal. Pump w/ 12hp Restriction
 NOTE: Must use Rear Ported Pump

Parts List & Belt Routings

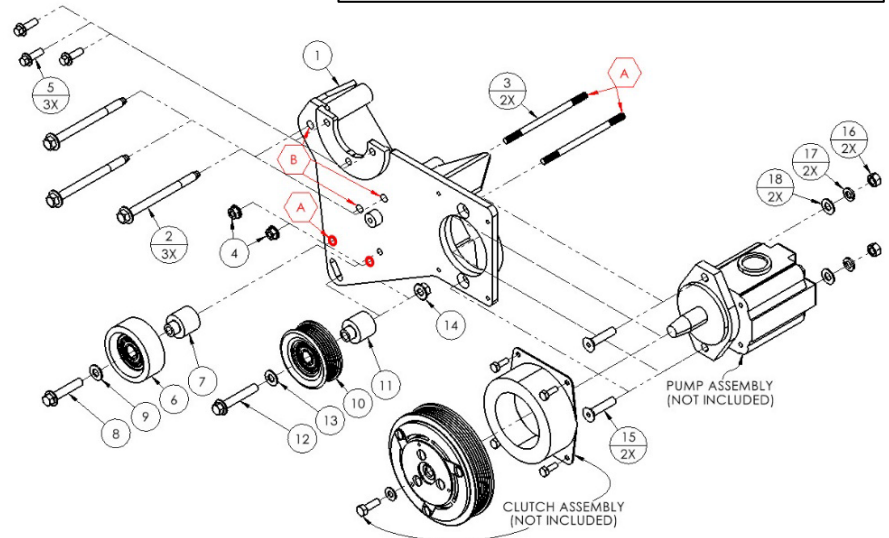
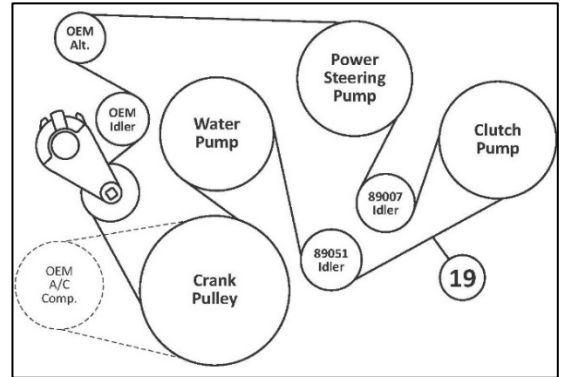
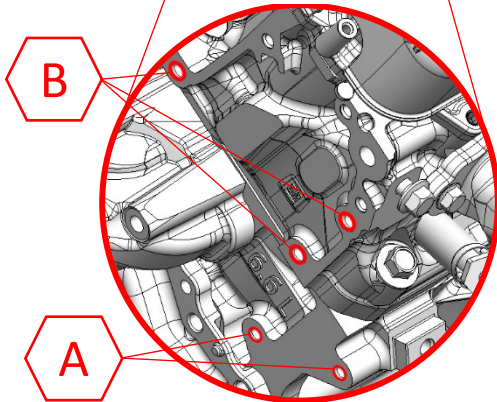
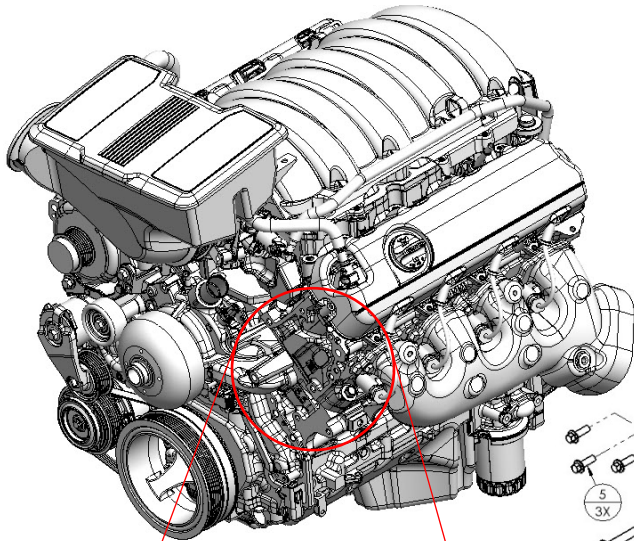

PARTS LIST							
Item	Part Number	Description	Qty.	Item	Part Number	Description	Qty.
Main Bracket				12	1018229	M10-1.5 x 60mm 10.9Gr Hex Flg. Bolt	1
1	CMB140A-I6	Main Bracket	1	13	1007644	3/8" USS Flat Washer	1
Main Bracket Mounting Hardware				14	1018204	M10-1.5 10.9Gr Hex Flg. Nut	1
2	N/A	OEM Power Steering Bracket Bolt	3	Clutch Pump Mounting Hardware			
3	1018292	M8-1.25 x 140mm Stud	2	15	1003930	3/8"-16 x 1-3/4" NC Gr5 FHSCS	2
4	1013333	M8-1.25 10.9Gr Hex Flg. Nut	2	16	1010314	3/8"-16 NC Gr5 Hex Nut	2
Power Steering Pump Mounting Hardware				17	1010315	3/8" Med Lock Washer	2
5	1011887	M8-1.25 x 25mm 10.9Gr Hex Flg. Bolt	3	18	1007644	3/8" USS Flat Washer	2
Smooth Idler Pulley Assembly				Belt (6" Clutch O.D.)			
6	89007	Dayco Smooth Idler Pulley	1	19	5061185	Dayco 6-Groove 118.5" Belt	1
7	CMB140-2	Machined Idler Bushing	1	Belt (5.5" Clutch O.D.)			
8	1006934	M10-1.5 x 50mm 10.9Gr Hex Flg. Bolt	1	19	5061178	Dayco 6-Groove 117.8" Belt	1
9	1007644	3/8" USS Flat Washer	1				
Grooved Idler Pulley Assembly							
10	89051	Dayco Grooved Idler Pulley	1				
11	CMB140-2	Machined Idler Bushing	1				

CW **CW Mill Equipment Co., Inc.**
14 Commerce Drive Sabetha, KS 66534
Phone: (785) 284-3454
Fax: (785) 284-3601
Email: brackets@cwmill.com
MOUNTING KITS Website: www.cwkits.com

CMK140A-I6

2020-2024 Chevrolet Silverado 2500HD-3500HD

2020-2024 GMC Sierra 2500HD-3500HD

6.6L V8 Gas w/-w/o A/C, w/o OEM Dual Alternators

Requires 6-Groove Clutch, SAE Two-Bolt "A" Flange Pump

Recommended 1.75 in.³ or 8 gal. Pump w/ 12hp Restriction

NOTE: Must use Rear Ported Pump

Wire Bracket Modification

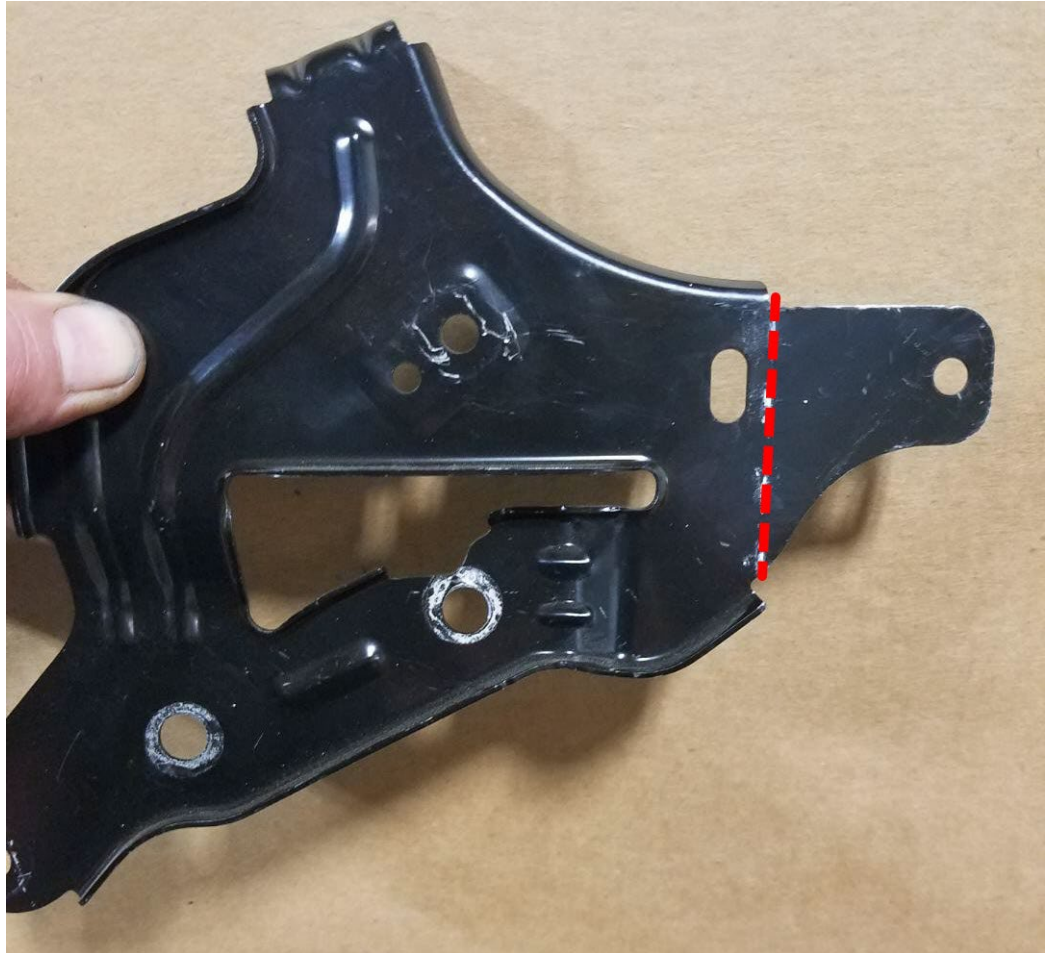

Cut at Red Dotted Line