

INSTALLATION NOTES

1. Disconnect negative battery cable. Remove the top half of the fan shroud and the fan. (*Fan nut is right hand threads*). It's not necessary to remove the fan and fan shroud, but makes installation easier. Remove the air cleaner duct and the O.E.M. belt.
2. Remove the three bolts holding the alternator bracket to the engine. Install the pump bracket (1) using those three hole locations on the alternator bracket with three 10mm x 140mm bolts (8) and lock-washers (7). Tighten bolts securely. Install pump bracket brace (2) using bolt (9) and bushing (3) at the engine, and bolt (10) at the back of the pump bracket. Tighten bolts (9) and (10) evenly so the brace does not pull the main bracket when tightened.
3. Install pump (12) onto the pump bracket with bolts provided. Make certain the clutch pulley is aligned with the OEM pulleys. Install idler (5) with bolt (6) and bushing (4) into the tapped hole located just below and to the inside of the pump. Install the belt, then load the tensioner and install the other idler into the lowest possible hole it will fit into on the front of the main bracket..
4. Replace the fan and top half of the fan shroud if removed. Replace the air duct.
Connect battery. Run the engine and check for proper belt tracking. Adjust if necessary.
5. If wires from the ECM run close to the belt or clutch, use 1/4 bolts, washers, spacers and nut to relocate the ECM to the fan shroud.

NOTE: Check all engine compartment hoses and electrical wiring that may have been disturbed or rerouted during kit installation to be sure that hoses are not kinked, that they do not touch any high temperature items, and that they do not interfere with any linkage components.

CMK 39-I6 Belts

2011-2013 Chevy Silverado 1500

2011-2017 Chevy Silverado 2500-3500

4.8,5.3,6.0

W-WO/AC

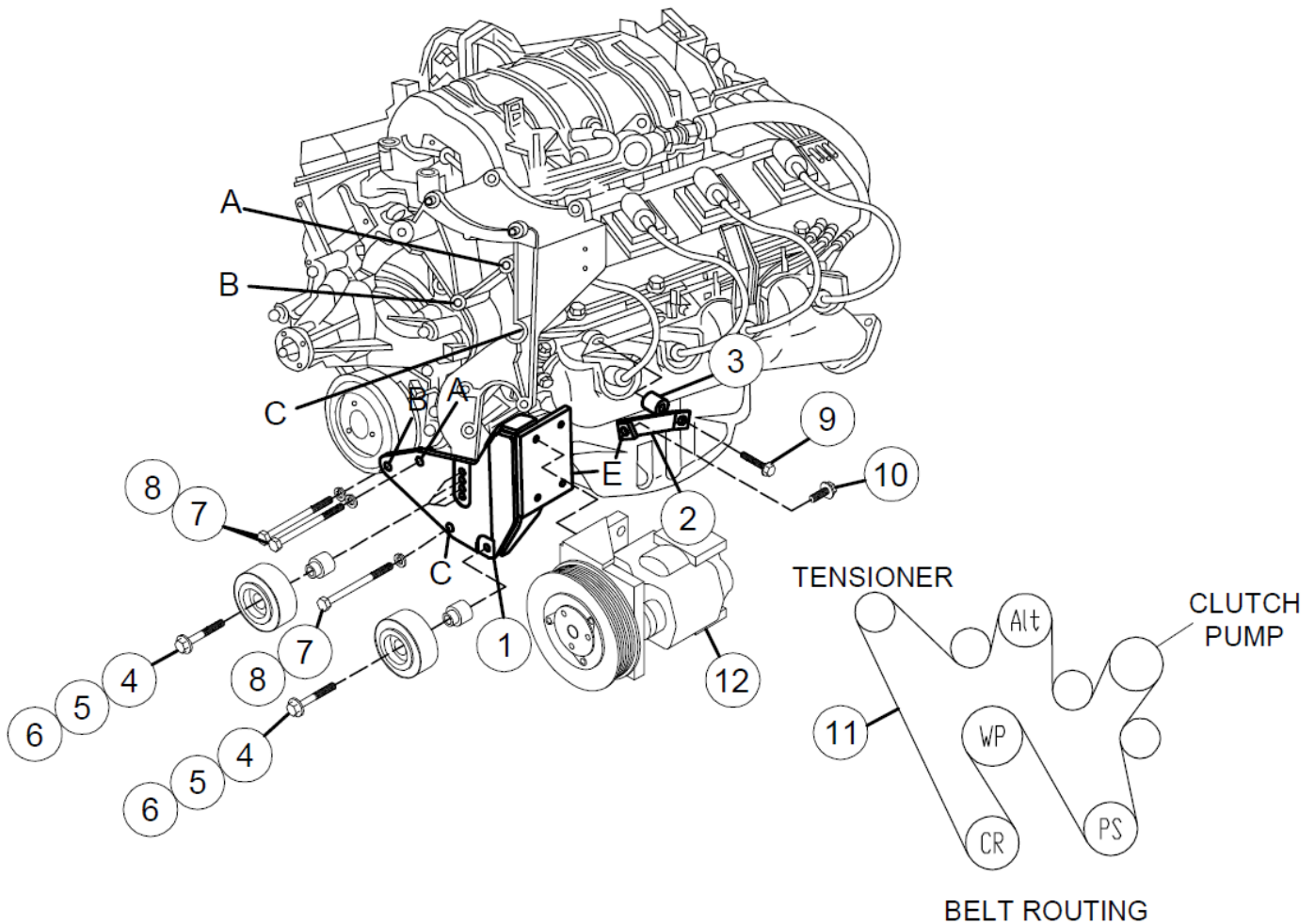

PARTS LIST

- | | |
|---|--|
| 1. CMP39(0-4) (1) | 9. 10mm x 50mm Flange Bolt (1) |
| 2. CMB391 (1) | 10. 10mm x 20mm Flange Bolt (1) |
| 3. SP100-1.200 (1) | 11. Belt Dayco 5061185 (1) |
| <i>(TIPKSC-39 Includes one of each items 4-6)</i> | 12. Clutch Pump Assembly (Sold Separately) |
| 4. CMB 3867 (2) | <u>ITEMS 13-16 NOT SHOWN</u> |
| 5. 89007 (2) | 13. 1/4 x 2 NC Bolt (4) |
| 6. 10mm x 40mm Flange Bolt (2) | 14. 1/4 Flat washer (4) |
| 7. 10mm Lock washer (3) | 15. 1/4 Nylock Nut (4) |
| 8. 10mm x 140mm 1.5 (3) | 16. SP64-0.500 Spacer (4) |