



CWMILL EQUIPMENT CO., INC.
P.O. Box 246 • Sabetha, Kansas 66534
(785) 284-3454 • FAX (785) 284-3601

DMK 36 -2 Belts

1993-99 Dodge 360
W-WO/AC
W/A.I.R. Pump
(Serpentine)

INSTALLATION NOTES

1. Disconnect battery cable. Remove fan, fan shroud and serpentine belt. Remove the six bolts on the crankshaft pulley. Remove center bolt and washer on balancer.
2. Install pulley pilot (2a) into balancer using bolt and lockwasher provided. Torque bolt (2b) to 135lb/ft. Install the drive pulley (1) and spacer (2) on the crankshaft using the six 5/16 Grade 8 bolts provided in the kit. Tighten securely.
3. Remove belt tensioner from the A.I.R. pump bracket. Disconnect coil wires and remove the A.I.R. pump and bracket. Remove the A.I. R. pump from the O.E.M. bracket and install it in the new bracket using the two 3/8 X 5 1/2" bolts provided in the kit. Bolt the new bracket (6) in the same place the O.E.M. bracket re-using the three O.E.M. bolts. (Tighten.) Install the serpentine belt tensioner. Using spacers provided in the kit, align the A.I.R. pump pulley with the belt tensioner and the other pulleys. Install serpentine belt. Remove coil from O.E.M. bracket and install it on the new bracket (6) using bolts (11) washers (12) and nuts (13), reconnect coil wires.
NOTE: Do not tighten the two A.I.R. pump bolts until the clutch pump has been installed and belts tightened.
4. Mount the clutch pump and align its pulley to the drive pulley (1). Install drive belts and adjust to proper tension.
5. Install fan spacer (5), fan, and fan shroud. Install coil (see note) and re-connect battery cable. Tighten A.I.R. pump bolts.

DMK 36 -2 Belts

1993-99 Dodge 360

W-WO/AC

W/A.I.R. Pump

(Serpentine)

NOTE: Remove aluminum smog pump bracket and replace with steel bracket. Use shims to space A.I.R. pump accordingly.

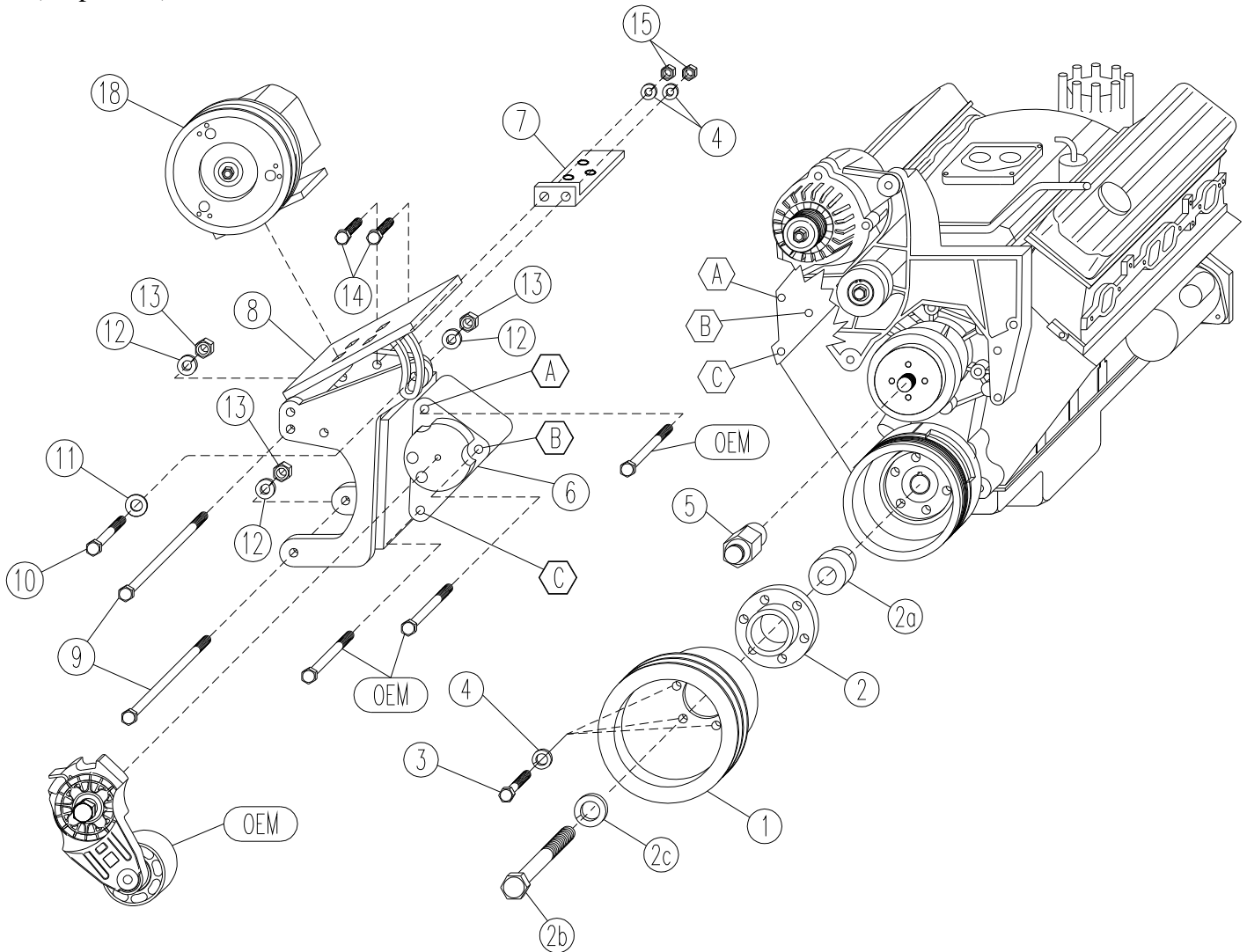

PARTS LIST

- | | | |
|------------------------------|------------------------|----------------------------------------------|
| 1. DPC 352 (1) | 4. 5/16 LW (11) | 11. 3/8 FW (1) |
| 2. DPA 365 (1) | 5. FSK 36R (1) | 12. 3/8 LW (3) |
| 2a. DPA 356 (1) | 6. DMB 361 (1) | 13. 3/8 NC (3) |
| 2b. 3/4 X 3 1/2 NF (1) | 7. DMB 362 (1) | 14. 5/16 X 1 NC (5) |
| 2c. 3/4 LW (1) | 8. DMP 36(0-4) (1) | 15. 5/16 NC (5) |
| 3. 5/16 X 2 1/4 NC GR. 8 (6) | 9. 3/8 X 5 1/2 NC (2) | 16. Assorted Spacers
(Not Shown) |
| | 10. 3/8 X 1 1/4 NC (1) | 17. AX-61 (Not Shown)
(#2 AX-60,#4 AX-59) |
| | | 18. Clutch Pump
(Sold Separately) |

NOTE: With 7" clutch #2 AX-61, #4 AX-60.