

INSTALLATION NOTES

1. Disconnect the negative battery cable. Drain the engine coolant. Remove the air filter assembly from the engine compartment. The filter assembly is held on by two small bolts located under the fender well. Remove the antifreeze/windshield washer fluid reservoir from the fan shroud. Drain the windshield washer fluid from the tank. Remove the fan shroud and fan. (Fan nut has left hand threads) Remove the upper radiator hose from the thermostat housing then remove the thermostat housing. Reusing the bolts, install the new thermostat housing (19) onto the engine. Torque bolts to 20 ft. lbs.
2. Remove the bolt from the engine dampener. Using a cutoff wheel or other suitable tool carefully cut the washer in half and remove it from the bolt. The bolt will be reused so be careful not to damage it. Install pulley (1) onto the front of the dampener with the O.E.M. bolt. Torque bolt to 135ft. lbs. Install set screws (2) into pulley (1) and run them in by hand until they all touch the dampener. Using a star pattern, tighten the set screws in 20 in. lb. increments to 100 in. lbs. A mild grade of loc-tite on the set screws is advisable.
3. Install bracket (3) onto the engine at locations A, B, C with bolts (4, 5, 6) and lock washers (7, 8). Torque bolts (4, 5) to 25 ft. lbs. and bolt (6) to 35 ft lbs. Remove the nut at location D and replace it with coupler nut (15). Torque to 25 ft. lbs. Remove the bolt at location E and install stud (11) until it bottoms out in the hole then install bushing (12) onto the stud. Install the front bracket (9) with nut (13) at location E, bolt (14) at location D and bolts (10) into bracket (3). Torque nut and bolt (13, 14) to 25 ft lbs and bolts (10) to 35 ft. lbs.
4. Install the clutch pump onto bracket (3) with bolts provided in the kit. Using a quality straight edge, align the pump with the drive pulley. Perfect alignment is critical for proper belt life and performance. With the pump aligned, torque the bolts to 35 ft. lbs. Install idlers (17) with bushings (16) and bolts (18). Torque idler bolts to 25 ft. lbs. Install tensioner (21) with bolt (22). Install the belt around the tensioner idler then torque the bolt to 30 ft. lbs. Install the pump belt and route as shown in the illustration. Replace the fan and fan shroud. Make sure there is adequate clearance (*1/4 minimum*) between the fan and the tensioner.
5. *(2009 only Using a heat gun, heat the windshield washer tank and compress it inward approximately 3/4" at the location shown in the illustration. Install the tank onto the fan shroud. There should be a minimum of 1/2" clearance between the clutch on the pump and the windshield washer tank.)*
6. Cut 8" from the engine end of the upper radiator hose and install it onto the new thermostat housing using hose clamp (20). On 2011 models, the upper radiator hose will also need to be rotated. Cut the hose and use the splice with clamps supplied so the hose can be rotated with out kinking it.
7. Install the air cleaner assembly. Replace the engine coolant and the windshield washer fluid.
Make certain any wires or hoses rerouted during installation do not come in contact with any hot or moving parts. Run the engine to check for proper belt tracking.

DMK40-6

2009-2017 Dodge Truck

D2500, 3500

5.7L Hemi

W/WO AC

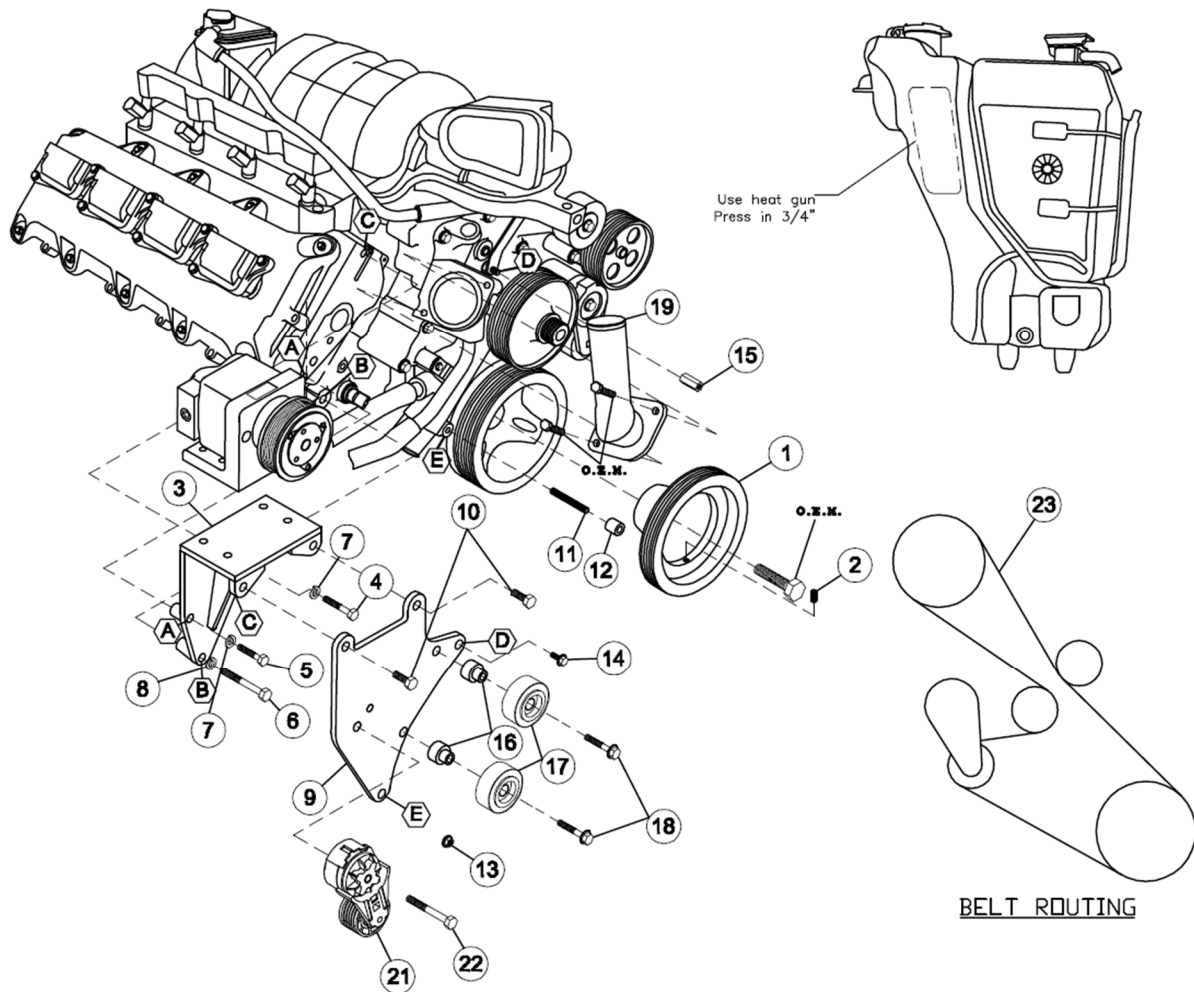

PARTS LIST

- | | | | |
|-----|----------------------------|-----|--|
| 1. | DPC 406 (1) | 13. | 8mm Flange Nut (1) |
| 2. | 8mm x 25mm Set Screw (3) | 14. | 8mm x 20mm Flange Bolt (1) |
| 3. | DMP 40(0-4) (1) | 15. | 8mm x 35.5mm Coupler Nut (1) |
| 4. | 8mm x 70mm (1) | 16. | CMB 3867 Bushing (2) |
| 5. | 8mm x 60mm (1) | 17. | 89007 Dayco Idler (2) |
| 6. | 10mm x 70mm (1) | 18. | 10mm x 30mm Flange Bolt (2) |
| 7. | 8mm LW (2) | 19. | DMB 401 (1) |
| 8. | 10mm LW (1) | 20. | #32 Hose Clamp (<i>not shown</i>) (1) |
| 9. | DMB 400 (1) | 21. | 89203-051 Tensioner (1) |
| 10. | 10mm x 20mm w/ .150 HD (2) | 22. | 10mm x 60mm Bolt (1) |
| 11. | 8mm x 175mm Stud (1) | 23. | #1 5060665, #2 5060655, #4 5060645 Dayco (1) |
| 12. | SP75-1.20 (1) | 24. | Clutch Pump (<i>Sold Separately</i>) |