



CW MILL EQUIPMENT CO., INC.
P.O. Box 246 • Sabetha, Kansas 66534
(785) 284-3454 • FAX (785) 284-3601

DMK584-I8AT

2011-2013 Dodge D-2500-3500

2013 Without remote mounted P.S. reservoir

6.7 Cummins Diesel

W-AC

INSTALLATION NOTES

1. Drain radiator below upper radiator hose. Remove upper radiator hose. Remove fan and fan shroud. Remove belt. Remove return hose from power steering reservoir and let reservoir drain. Remove bolts from power steering pump through the holes in the pulley. Leaving pressure lines attached, set pump aside on passenger side of engine. Remove power steering pump brackets.
2. *(If installing on a truck with a manual transmission skip to step 3.)* Remove Automatic transmission cooler lines from radiator side by removing quick clips. Drain fluid out of lines. Mark cooler lines in approximate location that they should be cut looking at the illustration. Check location by routing replacement hoses and adjust cut location if necessary. Cut with a tubing cutter and discard radiator side of the O.E.M. line. Install new hoses(23) as shown in illustration. **Note:** *Make sure to get compression fittings tight. Pressures in these lines may reach up to 300psi.*
3. Install studs (2) in timing cover w/nuts (3). Install pump onto adapter plate (11) using bolts (12) and pump spacer (13). Install pump and adapter plate (11) onto bracket (1) using bolts (14), lockwashers (15) and flatwashers (16). When installing pump and adapter plate to main bracket, line the back of the plates flush with each other. This will give a good start to aligning the clutch with the O.E.M. drive. Install 5/8 hose (18) onto return hose using hose barb (20) and hose clamps (19). Power steering lines on steering gearbox may need moved for proper clearance to the pump.
4. Install pump and bracket assembly onto studs (2) using nuts (3). Check alignment on pump and adjust if necessary. NOTE: It may be easier to install hoses and power wire before power steering pump is reinstalled. Install power steering pump onto bracket using bolts (4) and LW's (5). Install new belt (17) according to the belt diagram. Install idler (7) in lowest hole location possible while tensioner is retracted fully using bolt (8) and bushing (6).
5. Install hose rest (9) onto cylinder head on driver side using flange head bolts (10). Cut 3/4" off radiator side of top radiator hose and reinstall. Connect new power steering return hose (18) to power steering reservoir using OEM hose clamp. Fill power steering reservoir w/ATF Plus 4 transmission fluid. *(If installing on a truck with automatic transmission)* Top off transmission w/ATF Plus 4 transmission fluid. Reinstall fan and fan shroud. Fill radiator and overflow tank. Check for proper belt tracking and clearances.

DMK584-I8AT

2011-2013 Dodge Truck 2500-3500

2013 Without remote mounted P.S. reservoir

6.7 Cummins Diesel

W-AC

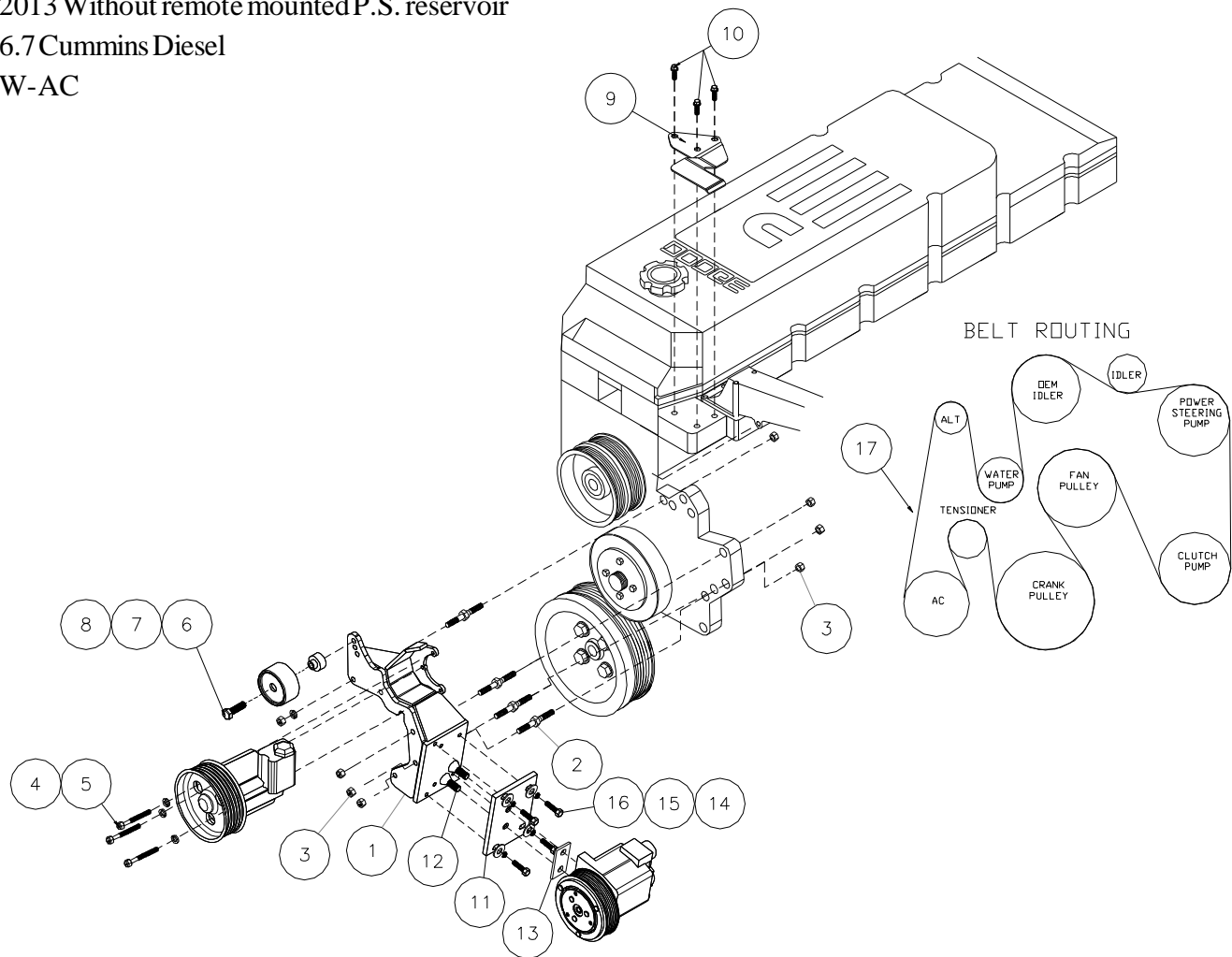

PARTS LIST

- | | |
|--------------------------------|-------------------------------------|
| 1. DMP582-I8 (1) | 13. 1/4" Pump Tab (1) |
| 2. 8mm Stud 080751.25 ST (4) | 14. 3/8 x 1 NC (4) |
| 3. 8mm Flange Nut (8) | 15. 3/8 LW (4) |
| 4. 8mm x 80mm (3) | 16. 3/8 FW (4) |
| 5. 8mm LW (3) | 17. 5081300 Dayco (1) |
| 6. DMB562 (1) | ITEMS 18-22 NOT SHOWN |
| 7. 89016 Dayco (1) | 18. 14" of 5/8" Oil Hose (1) |
| 8. 10mm x 40mm Flange Bolt (1) | 19. #10 Hose Clamp Dayco (2) |
| 9. DMB 563 (1) | 20. 5/8" Double Ended Hose Barb (1) |
| 10. 10mm x 20mm Flange (3) | 21. 3/8 LW (2) |
| 11. DMP574 (1) | 22. 15" Plastic Tie Strap (1) |
| 12. 1/2 X 1 3/4 FHSCS (2) | 23. D58TCHK (1) |

Transmission cooler line modifications

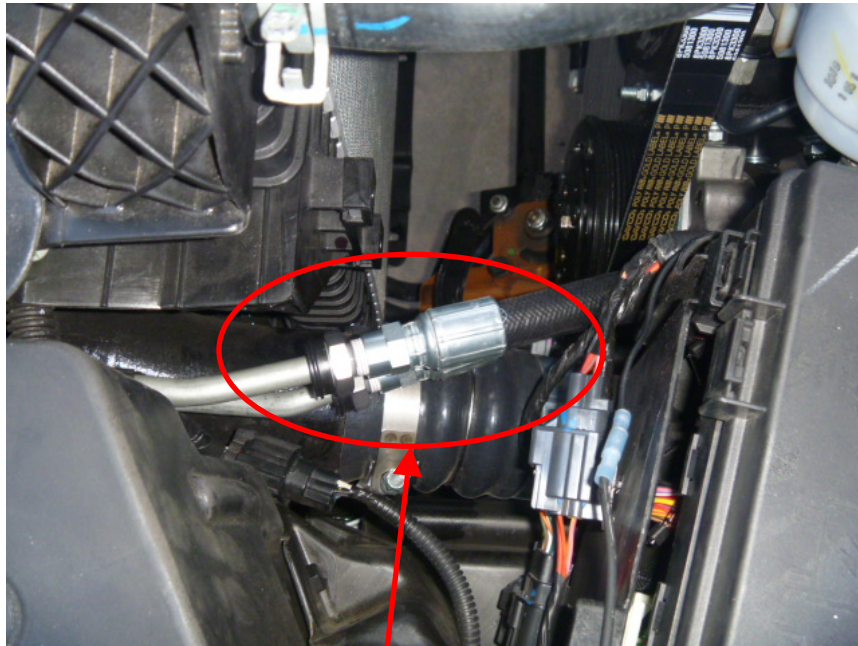

Install quick clip end of hoses to radiator side.



Cut transmission cooler lines and install hoses using the compression fittings making sure to get them tight enough without collapsing tube to prevent leaking.