



CW MILL EQUIPMENT CO., INC.  
P.O. Box 246 • Sabetha, Kansas 66534  
(785) 284-3454 • FAX (785) 284-3601

FMK 21 -2 Belts 80-82  
FMK 22-2 Belts 83-86  
FMK 23 -2 Belts 87-92  
FMK 24 -2 Belts 93-96  
Ford Truck F-150,250,350  
300 I-6 (4.9L) W-WO/AC

## INSTALLATION NOTES

1. Disconnect battery terminal. Remove fan. **NOTE:** '83-'86 models use left hand threads on fan; '87-'94 models have right-hand threads.
2. Remove bolt and washer from center of crankshaft pulley. Install drive pulley (1) with provided bolts, discard O.E.M. washer. **CAUTION:** Be sure threads are the same as removed O.E.M. bolt.
3. On '80-'86 models: remove nuts from studs at locations "A & D". Replace with spacer nuts (13), do not use lockwashers. Remove bolts at locations "B & C". Using spacers and bolts described for each location, install bracket (7) to engine "A" - 1 ea. (12,15,16), "B" - 1 ea. (9,12,14,16), "C" - 1 ea. (15,16).  
  
On '87-'93 models: thread spacer nuts (13) over O.E.M. nuts on studs at locations "A & C". Remove bolts at locations "B & D". Use bolts (15) at locations "A & C". At locations "B & D", use spacers (9) and either (10 or 11), depending on length of O.E.M. nuts on studs "A & C", with bolts (14).  
  
On 94 models: use 2 ea. 1 3/4" spacers and 7/16 X 3" NC bolts and lockwashers at locations "B & D". Use O.E.M. studs and nuts at locations "A & C".
4. Install pump plate (8) to bracket (7) with bolts (17 & 19).
5. Mount clutch pump (24) to pump plate with bolts (19). Align clutch pulley with steel drive pulley (1). Tighten pump bolts securely. Install pump drive belts (23). Adjust mounting plate (8) for proper belt tension using jack bolts (18). Tighten bolts (17 & 19) on pump plate.
6. Install fan spacer (6) and fan. Be sure fan is secured. Connect battery terminal.
7. After plumbing pump with suction and pressure hoses, check clearance with steering linkage while tires are turned as much as possible to the passenger side (right). A shorter length of belt may be necessary if there is contact. Be sure hoses do not interfere with any linkage components.

**NOTE:** It is necessary to use a side ported pump as clearance to the crossmember is minimal. Install fittings to pump before installing it to pump plate.

**NOTE:** Visually make certain that there is adequate clearance between fan and drive pulley, and also fan to radiator. It may be necessary to use a longer spacer for pulley clearance. If there is little clearance to the radiator, check with your local Ford dealer to insure that it will not flex into the radiator before operating. Provide adequate clearance between fan and radiator before operating. Move radiator if necessary.

**FMK 21 -2 Belts    80-82 FORD 300 I-6 (4.9L) W-WO-AC**  
**FMK 22 -2 Belts    83-86**  
**FMK 23 -2 Belts    87-92**  
**FMK 24 -2 Belts    93-96**

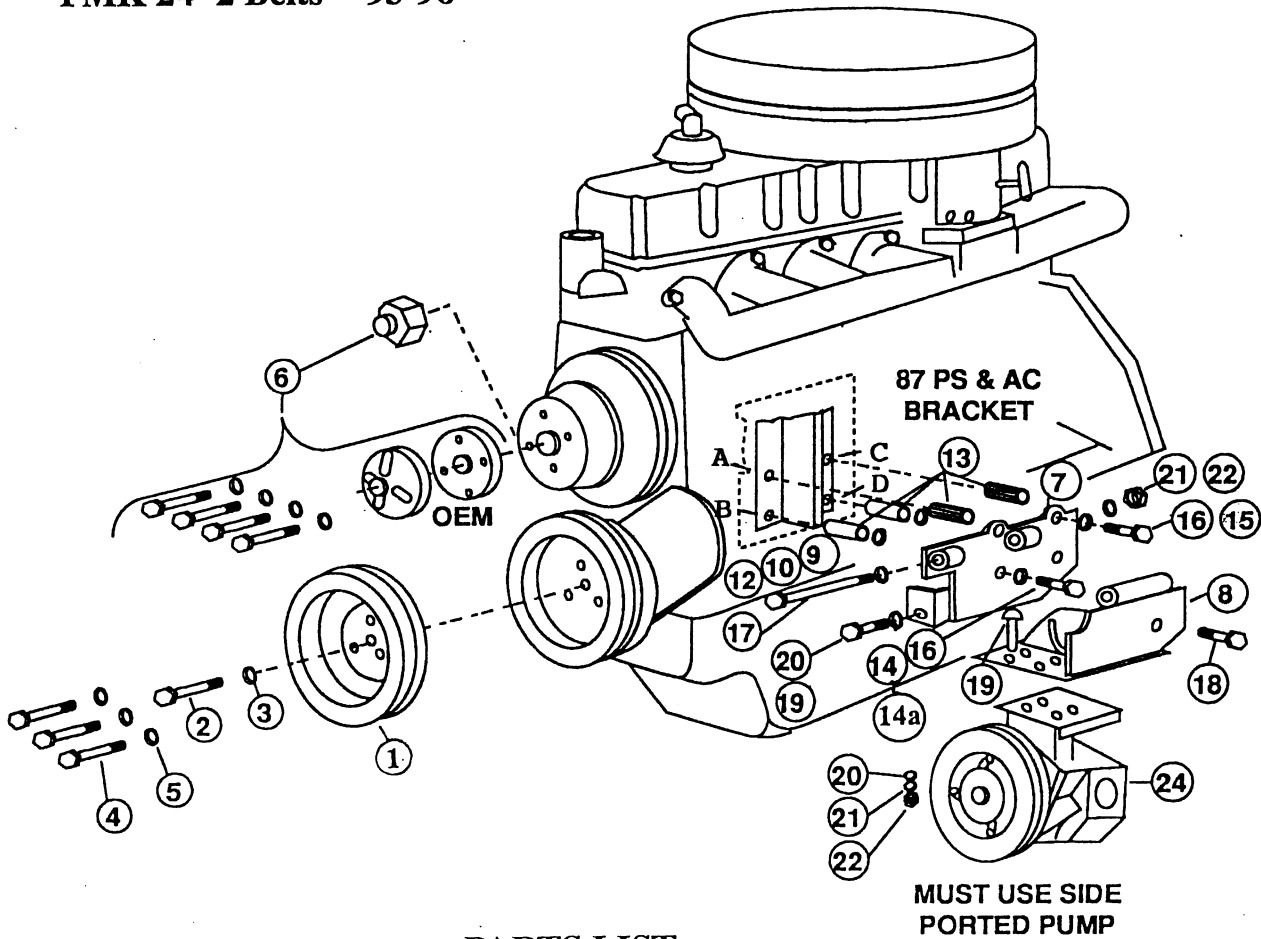

### PARTS LIST

- |                               |   |
|-------------------------------|---|
| 1. FPC 212 (1)                | 11. SP88-0.375 (2)                            |
| 2. 5/8 X 3 NF (1)             | 12. SP88-0.187 (2)                            |
| 3. 5/8 LW (1)                 | 13. SP7/16 NC 1.750 (2)                       |
| 4. 3/8 X 2 NC (3)             | 14. 7/16 X 4 NC (2)                           |
| 5. 3/8 LW (3)                 | 14a. 7/16 X 3 NC (2)                          |
| 6. FSK 508B (1) <b>FMK 21</b> | 15. 7/16 X 1-1/4 NC (2)                       |
| 5/16 X 3 1/2 NF (4)           | 16. 7/16 LW                                   |
| 5/16 LW (4)                   | 17. 3/8 X 5 NC (1)                            |
| FSK 30L (1) <b>FMK 22</b>     | 18. 3/8 X 1-1/2 SQ. (1)                       |
| FSK 30R (1) <b>FMK 23</b>     | 19. 3/8 x 1-1/2 NC (5)                        |
| FSK 24 (1) <b>FMK 24</b>      | 20. 3/8 FW (5)                                |
| 7. FMB 210 (1)                | 21. 3/8 LW (6)                                |
| 8. FMP 21(0-4) (1)            | 22. 3/8 NC (5)                                |
| 9. SP88-1.750 (2)             | 23. AX-35 (2) <b>FMK 24</b> AX-34 (Not Shown) |
| 10. SP88-0.500 (2)            | 24. Clutch Pump Assembly (1)                  |
|                               | (Sold Separately)                             |