



## FMK241A-I6DA

2020-2022 Ford F-250-F-550 Super Duty  
2020-2022 Ford F-600 Super Duty  
7.3L V8 Gas w/-w/o A/C, w/ OEM Dual Alternators

Requires 6-Groove Clutch, SAE Two Bolt 'A' Flange Pump  
Recommended 1.75 in.<sup>3</sup> or 8 gal. Pump w/ 12hp Restriction  
**NOTE: Must Use Rear Ported Pump**

### INSTALLATION NOTES

---

1. The buyer is responsible for providing trained and experienced installation decision making with technical know-how to apply professional judgment that specifically applies to each individual installation.
2. Be sure to read and understand all available information including but not limited to instructions, warnings, sale terms, and warranties for the vehicle and all system components prior to attempting installation.
3. Disconnect both battery cables. Drain coolant low enough for removal of upper radiator hose. Disconnect the upper radiator hose at the radiator.
4. Remove fan clutch wire and bracket from engine. Remove OEM belt. Disconnect alternator wires and lay aside. Remove both OEM alternators. Remove OEM alternator bracket and bolts. The bolts will not be reused.
5. Install main bracket (1) with bolts (2) and lock washers (3) onto the engine block (make sure to install bolt into bracket hole closest to water pump before installing bracket).
6. Install wire extension (12) to OEM main alternator wire with hardware (14-15) and heat shrink (13). Install OEM main alternator with OEM bolt (7) and bolt (8) onto main bracket (1). Install the two smooth idler pulley assemblies (4-6) onto main bracket (1) (install in hole furthest from the water pump). Install OEM secondary alternator with bolts (9) onto main bracket (1) (make sure wire harness is placed between the two mounting holes). Install clutch pump assembly onto main bracket (1) according to the manufacturers' specifications with provided mounting hardware (10-11). Install wires to both alternators.
7. Install belt (22). Reinstall fan wire and OEM wire bracket.
8. Remove factory clamp from radiator hose (this is done by cutting at holes and separate plastic clamp). Install rubber elbow (17) with hose clamps (19) installed loosely onto the upper radiator hose quick disconnect. Install steel tube (16) with the expanded end into the rubber elbow (17) and adjust as shown in the photo. Mark and cut the OEM upper radiator hose at the appropriate location so it will slip over the steel tube (16) by approximately 1½". Install hose clamp (18) loosely. Then, push steel tube (16) into the modified OEM upper radiator hose. Adjust hose for best fit and clearance to the clutch. Then, tighten all hose clamps and secure the hose to the fan shroud with loom clamp (20) and bolt (21).
9. Reconnect the upper radiator hose quick disconnect to the radiator if needed. Replace the engine coolant and check for leaks.

**CAUTION:** Before starting the engine. Check to make certain no wires, hoses, etc. that may have been disturbed during installation do not come in contact with any hot or moving parts. Run the engine and check for proper belt tracking, adjust if necessary.

# FMK241A-I6DA

2020-2022 Ford F-250-F-550 Super Duty  
 2020-2022 Ford F-600 Super Duty  
 7.3L V8 Gas w/w/o A/C, w/ OEM Dual Alternators

Requires 6-Groove Clutch, SAE Two Bolt 'A' Flange Pump  
 Recommended 1.75 in.<sup>3</sup> or 8 gal. Pump w/ 12hp Restriction  
**NOTE: Must Use Rear Ported Pump**

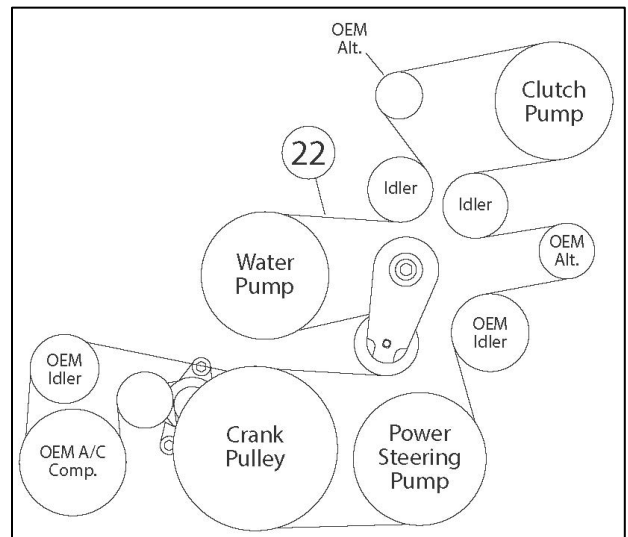
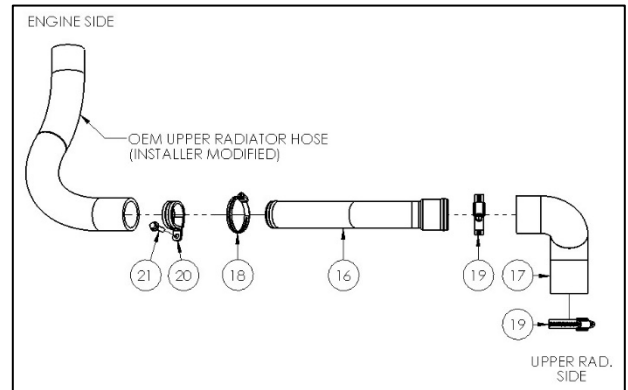
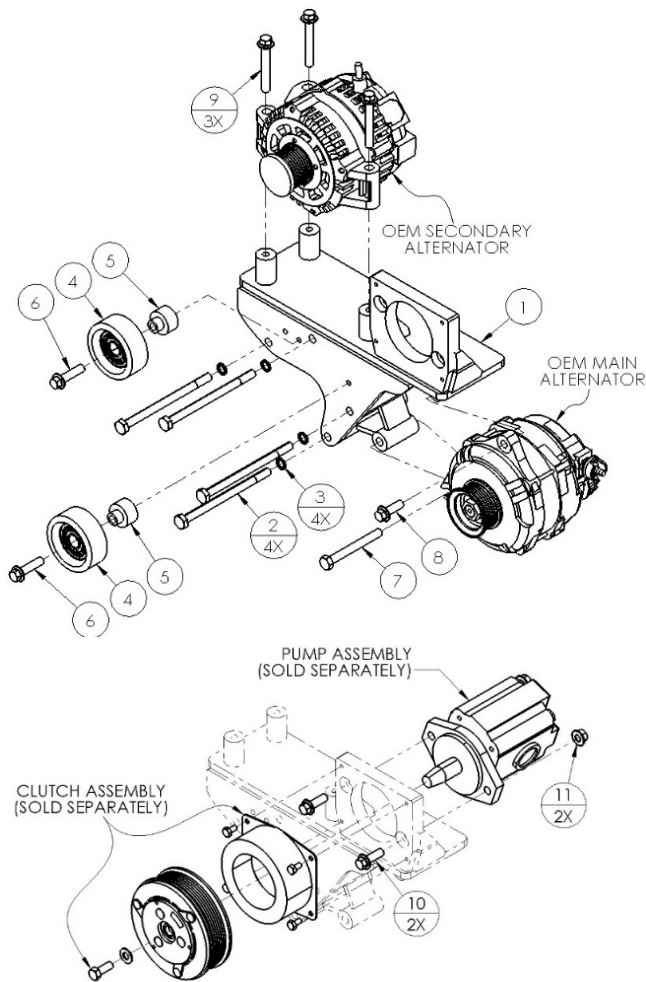

PARTS LIST							
Item	Part Number	Description	Qty.	Item	Part Number	Description	Qty.
<b>Main Bracket</b>				<b>Wire Extension (Not Shown)</b>			
1	FMB241A-I6	Main Bracket	1	12	FMB241WE	Wire Extension	1
<b>Main Bracket Mounting Hardware</b>				13	1005393	Heat Shrink	3"
2	1005275	M10-1.5 x 150mm 10.9Gr Hex Bolt	4	14	1011623	M8-1.25 x 12mm 10.9Gr Hex Flg. Bolt	1
3	1003822	M10-1.5 Lock Washer	4	15	1013333	M8-1.25 10.9Gr Hex Flg. Nut	1
<b>Smooth Idler Pulley Assembly (2x)</b>				<b>Upper Radiator Hose Modification Assembly</b>			
4	89007	Dayco Smooth Idler Pulley	2	16	FMB241-2	Fabricated Steel Tube	1
5	FMB241-1	Machined Idler Bushing	2	17	FMB241-3	Custom Modified Rubber Elbow	1
6	1006933	M10-1.5 x 40mm 10.9Gr Hex Flg. Bolt	2	18	1016325	#24 Hose Clamp	1
<b>OEM Main Alternator Mounting Hardware</b>				19	1006199	#28 Hose Clamp	2
7	N/A	OEM M10-1.5 x 90mm Bolt	1	20	1017265	#32 Loom Clamp	1
8	1006927	M10-1.5 x 30mm 10.9Gr Hex Flg. Bolt	1	21	1016341	M6-1.0 x 25mm 10.9Gr Hex Flg. Bolt	1
<b>OEM Secondary Alternator Mounting Hardware</b>				<b>Belt</b>			
9	1016343	M10-1.5 x 70mm 10.9Gr Hex Flg. Bolt	3	22	5061115	Dayco 6-Groove 111.5" Belt	1
<b>Clutch Pump Mounting Hardware</b>							
10	1006927	M10-1.5 x 30mm 10.9Gr Hex Flg. Bolt	2				
11	1018204	M10-1.5 10.9Gr Hex Flg. Nut	2				

**CW** **CW Mill Equipment Co., Inc.**  
14 Commerce Drive Sabetha, KS 66534  
Phone: (785) 284-3454  
Fax: (785) 284-3601  
Email: brackets@cwmill.com  
**MOUNTING KITS** Website: [www.cwkits.com](http://www.cwkits.com)

# FMK241A-I6DA

2020-2022 Ford F-250-F-550 Super Duty  
2020-2022 Ford F-600 Super Duty  
7.3L V8 Gas w/-w/o A/C, w/ OEM Dual Alternators

Requires 6-Groove Clutch, SAE Two Bolt 'A' Flange Pump  
Recommended 1.75 in.<sup>3</sup> or 8 gal. Pump w/ 12hp Restriction  
**NOTE: Must Use Rear Ported Pump**

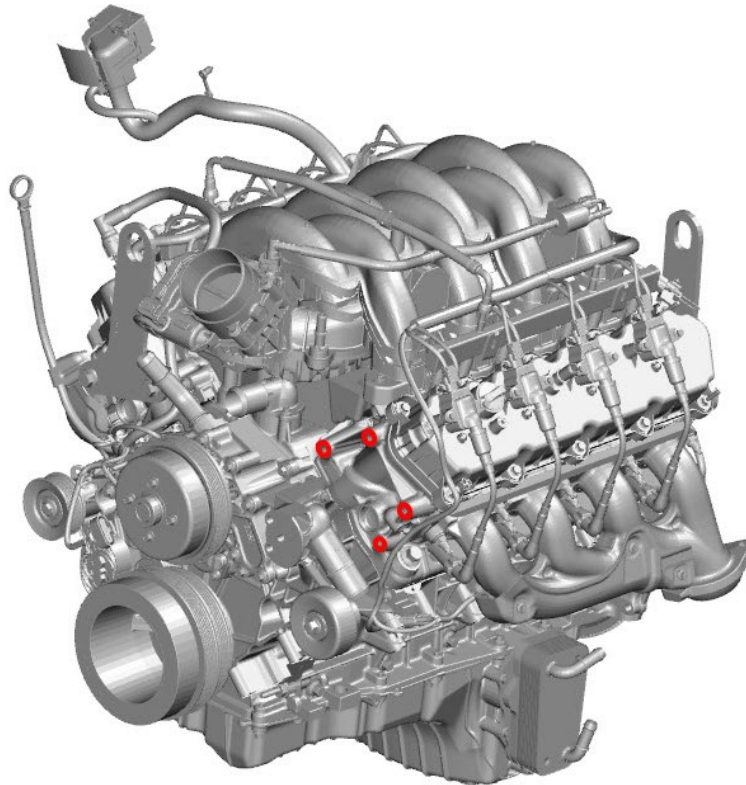

Main Bracket Mounting Location



As Shown: Auxiliary Clutch Pump Application

**CW** **CW Mill Equipment Co., Inc.**  
14 Commerce Drive Sabetha, KS 66534  
Phone: (785) 284-3454  
Fax: (785) 284-3601  
Email: brackets@cwmill.com  
**MOUNTING KITS** Website: [www.cwkits.com](http://www.cwkits.com)

# FMK241A-I6DA

2020-2022 Ford F-250-F-550 Super Duty  
2020-2022 Ford F-600 Super Duty  
7.3L V8 Gas w/-w/o A/C, w/ OEM Dual Alternators

Requires 6-Groove Clutch, SAE Two Bolt 'A' Flange Pump  
Recommended 1.75 in.<sup>3</sup> or 8 gal. Pump w/ 12hp Restriction  
**NOTE: Must Use Rear Ported Pump**

## NOTES

---

Disclaimer: (1.) Due to the custom nature and variation of all add-on systems of this type, no complete system kits are offered by the manufacturer, and any group of parts marketed as a kit is limited to only the individually defined parts in that specific kit. The system designer's rotating accessory components are not included, offered, or fully known by the manufacturer. In addition to the absence of the rotating accessory system, other potential components such as additional clamps, brackets, wear liners, hardware, or other items that may be required by the system designer must be identified and supplied by the actual system designer. (2.) Due to vehicle manufacturer's assembly tolerances, production changes, and installation variances, it is the buyer's responsibility to ensure adequate clearance for all components including space for and safe location of the fan, radiator, all lines, and wires. Check for possible movement, vibration, friction points, heat exposure and/or shifting of any and all components such as hoses, wires, and all other components including those that may otherwise be considered non-moving and/or unaffected by the installation (3.) The buyer is responsible for the entire installation of a mounting kit as the mounting kit is part of a custom process controlled by the buyer through their whole system design and directed installer as the installer evaluates, locates, routes, aligns, and tightens all components while determining if additional clamps, brackets, wear-liners, or other components may be required, beyond those included in the kit. Any additional items required, beyond those included in the kit, are to be provided at the expense of the buyer. (4.) The buyer is responsible for the development and communication of their whole system installation procedures, safety precautions, application, and use of the engine accessory mounting kit in their system, including efforts to maintain vehicle control and prevent pinch, wear, impact, and/or burn exposure on all hoses, wires, and other parts. (5.) The buyer is responsible for providing trained and experienced installation decision making with technical know-how to apply professional judgment that specifically applies to each individual installation. The buyers chosen installers must be qualified and experienced technicians that are familiar with the vehicle and accessory being mounted as well as the buyer's whole system design and installation procedures associated with the kit. (6.) The buyer is responsible for determining and achieving compliance to all regulatory issues that apply to the use of all products. (7.) The manufacturer reserves the right to make changes and/or improvements to any product at any time with or without notice.