



**CW Mill Equipment Co., Inc.**  
 14 Commerce Drive Sabetha, KS 66534  
 Phone: (785) 284-3454  
 Fax: (785) 284-3601  
 Email: brackets@cwmill.com  
 Website: [www.cwkits.com](http://www.cwkits.com)

**FMK53A-8SB**  
**2016-2019 Ford F650-750**  
**6.8L V10 Gas 3 Valve**  
 • For Use W-WO AC

- Requires Two Bolt "A" Flange Pump
- Kit Supplied W/ Bearing Support
- Requires 8 Groove Clutch

## INSTALLATION NOTES

1. Be sure to read and understand all available information including but not limited to instructions, warnings, sale terms, and warranties for the vehicle and all system components prior to attempting installation.
2. Disconnect negative battery cable. Remove air duct. Remove top half of the fan shroud. (It is not necessary to remove the upper radiator hose, but it does make it easier to remove the fan shroud.)
3. Install the pulley drive adaptor (4) onto the engine damper with three 10mm X 20mm socket head cap screws (5). Remove the nut and transmission coolant line brace from the stud at the lower right hand side of the engine. Install the drive pulley (3) with the belt (19) onto the engine with two 10mm flange nuts (7) and 10mm X 40mm flange bolt (6). The short leg on the support bracket will be inside the belt loop.
4. Remove the nut and the radio noise suppressor from the upper timing cover stud on the left side of the engine. Check OEM studs for proper torque. Install the clutch pump bracket (1) with the three shoulder nuts provided (8)(9). The longer nut goes in the lowest mounting hole. Tighten securely. Install the brace with the 16mm X 70mm bolt (10) and 10mm X 20mm flange bolt (11). Bolt radio noise suppressor to the top of the bracket with the 8mm X 12mm flange bolt (12).
5. Install idlers (13) with hardware (14)(15)(16) and tensioner (17) onto the bracket with 10mm x 72mm bolt (18). Install clutch pump, coil and clutch onto the bracket. Install the belt and route it as shown.
6. Install fan spacer (20) onto the water pump. Replace the fan shroud and air duct. (Connect upper radiator hose if removed and replace coolant.) Run engine and check for proper belt tracking.

## PARTS LIST

ITEM #	DESCRIPTION	PART #	QTY.			
				12.	8mm x 12mm Flg Bolt	1011623 1
1.	Main Bracket	FMP53A	1	13.	Idler	89016 2
2.	Brace	FMB530	1	14.	Idler Bush .875	FMB531 2
3.	Pulley *	FPC458	1	15.	10mm x 50mm Flg Bolt	1006934 2
4.	Pulley Adapter *	FPA45	1	16.	3/8 Flat Washer	1007644 4
5.	10mm x 20mm SHCS *	1009978	3	17.	Tensioner	89446-8 1
6.	10mm x 40mm Flg Bolt *	1006933	1	18.	10mm x 72mm Bolt	1007652-F53 1
7.	10mm Flg Nut *	1006935	2	19.	Belt *	5080780 1
8.	8mm Shldr Nut Short	F240SN1	2	20.	Fan Spacer	FSK6.8B 1
9.	8mm Shldr Nut Long	F240SN2	1	21.	3/8 x 1-1/4 Bolt	1009929 2
10.	16mm x 70mm Bolt	1005676	1	22.	3/8 Lock Washer	1010315 2
11.	10mm x 20mm Flg Bolt	1008390	1	23.	3/8 Nut	1010314 2

**\* If using 5.5" Clutch, Belt #5080780 - If using 6" Clutch, Belt #5080785**

**\* FPC458A Includes Items 3-7**

# FMK53A-8SB

2016-2019 Ford F650-750, 6.8L V10 Gas 3 Valve

- For Use W-WO AC
- Requires Two Bolt "A" Flange Pump
- Kit Supplied W/ Bearing Support
- Requires 8 Groove Clutch

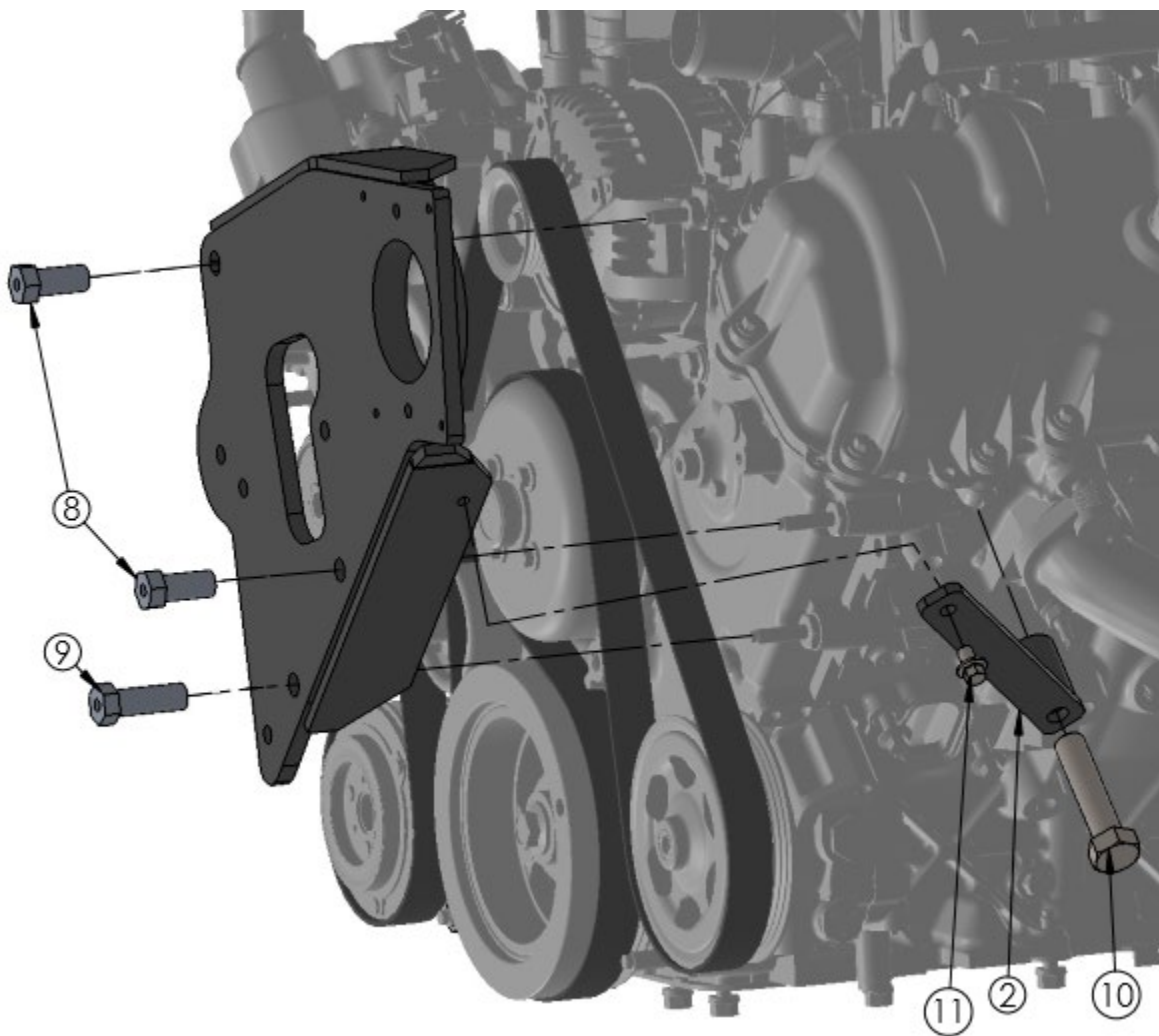

# FMK53A-8SB

2016-2019 Ford F650-750, 6.8L V10 Gas 3 Valve

- For Use W-WO AC
- Requires Two Bolt "A" Flange Pump
- Kit Supplied W/ Bearing Support
- Requires 8 Groove Clutch

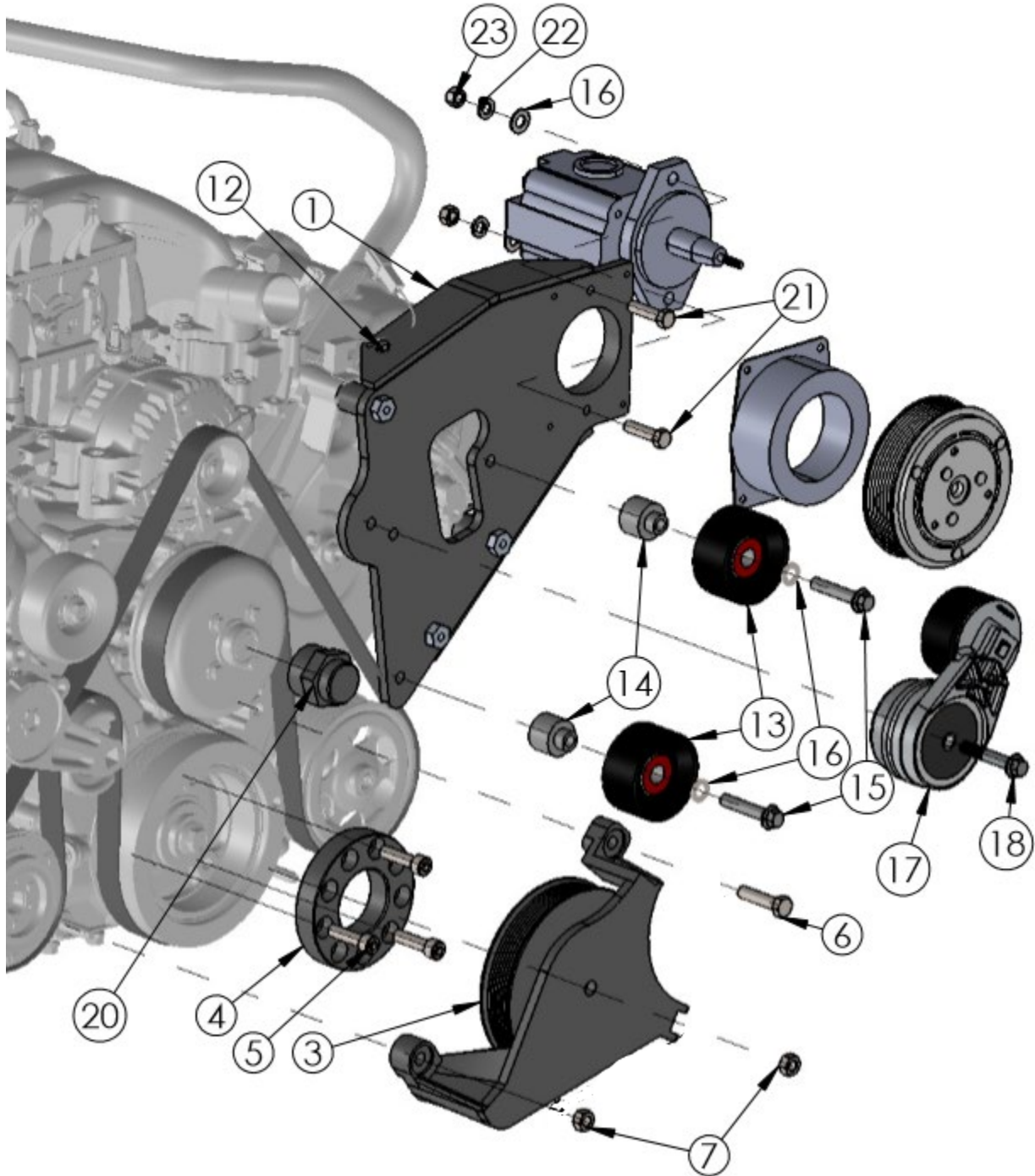

# FMK53A-8SB

2016-2019 Ford F650-750, 6.8L V10 Gas 3 Valve

- For Use W-WO AC
- Requires Two Bolt "A" Flange Pump
- Kit Supplied W/ Bearing Support
- Requires 8 Groove Clutch

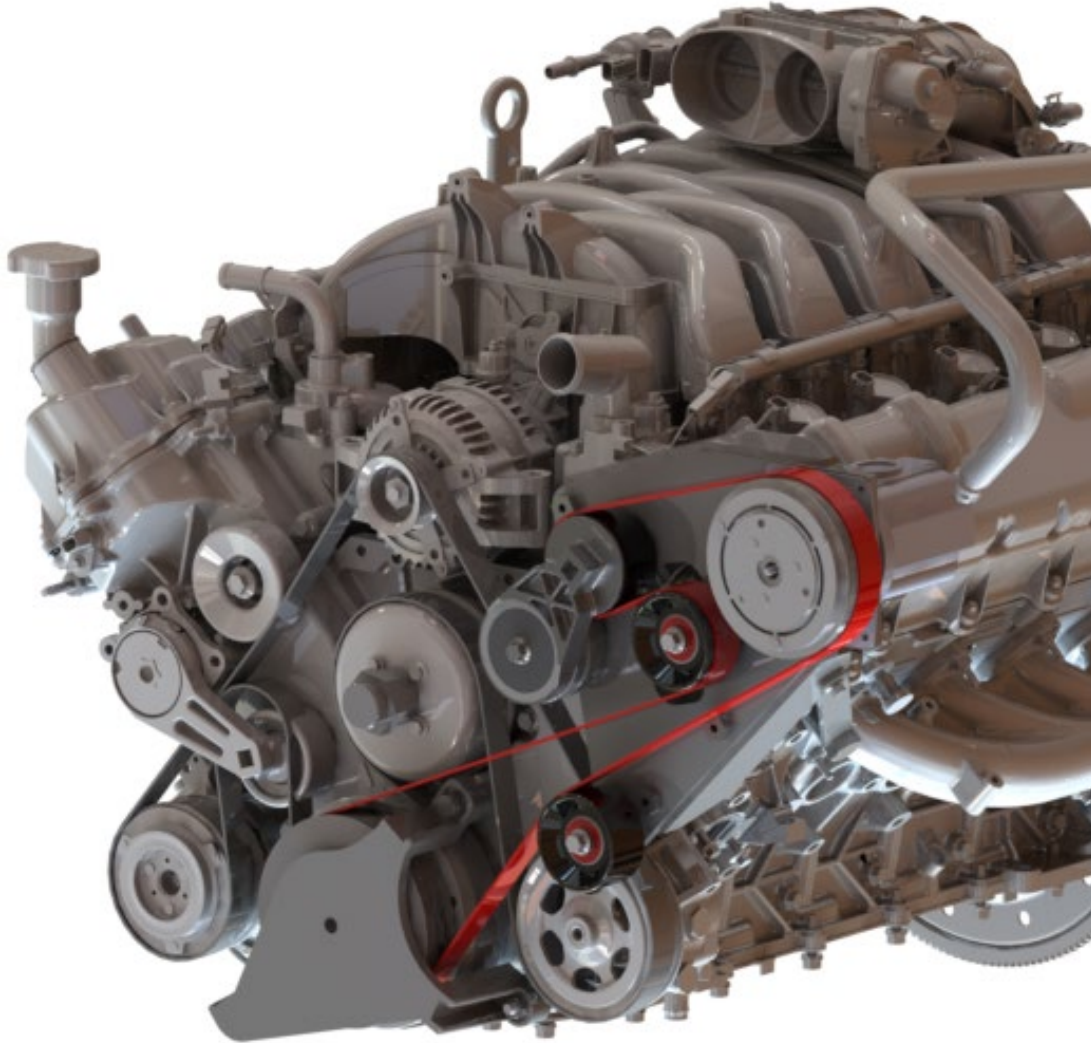

Disclaimer: (1.) Due to the custom nature and variation of all add-on systems of this type, no complete system kits are offered by the manufacturer, and any group of parts marketed as a kit is limited to only the individually defined parts in that specific kit. The system designer's rotating accessory components are not included, offered, or fully known by the manufacturer. In addition to the absence of the rotating accessory system, other potential components such as additional clamps, brackets, wear liners, hardware, or other items that may be required by the system designer must be identified and supplied by the actual system designer.

(2.) Due to vehicle manufacturer's assembly tolerances, production changes, and installation variances, it is the buyer's responsibility to insure adequate clearance for all components including space for and safe location of the fan, radiator, all lines, and wires. Check for possible movement, vibration, friction points, heat exposure and/or shifting of any and all components such as hoses, wires, and all other components including those that may otherwise be considered non-moving and/or unaffected by the installation (3.) The buyer is responsible for the entire installation of a mounting kit as the mounting kit is part of a custom process controlled by the buyer through their whole system design and directed installer as the installer evaluates, locates, routes, aligns, and tightens all components while determining if additional clamps, brackets, wear-liners, or other components may be required, beyond those included in the kit. Any additional items required, beyond those included in the kit, are to be provided at the expense of the buyer. (4.) The buyer is responsible for the development and communication of their whole system installation procedures, safety precautions, application, and use of the engine accessory mounting kit in their system, including efforts to maintain vehicle control and prevent pinch, wear, impact, and/or burn exposure on all hoses, wires, and other parts. (5.) The buyer is responsible for providing trained and experienced installation decision making with technical know-how to apply professional judgment that specifically applies to each individual installation. The buyers chosen installers must be qualified and experienced technicians that are familiar with the vehicle and accessory being mounted as well as the buyer's whole system design and installation procedures associated with the kit. (6.) The buyer is responsible for determining and achieving compliance to all regulatory issues that apply to the use of all products. (7.) The manufacturer reserves the right to make changes and/or improvements to any product at any time with or without notice.