



CW MILL EQUIPMENT CO., INC.  
P.O. Box 246 • Sabetha, Kansas 66534  
(785) 284-3454 • FAX (785) 284-3601

**FMK 66 -2 Belts**  
1999-2003 Ford Truck 250-550  
7.3 Direct Injected Intercooled Diesel  
W-WO/AC or Dual Alternator

## INSTALLATION NOTES

1. Disconnect the negative battery cables. Drain the engine coolant until coolant level is below the thermostat housing. Remove the tire wrench and jack tools from the radiator support. Remove the three bolts from the coolant reservoir and move it aside. Remove the upper radiator hose, the fan and fan shroud. The fan nut has right hand threads.
2. Install drive pulley (1) on the front of the harmonic balancer with bolts (2) and lockwashers (3). Remove plastic 7.3 cover and it's mounting bracket from the top of engine. Unload belt tensioner and remove belt. Remove alternator from bracket and lay on top of engine.
3. Use powersteering pulley puller, (Snap-On PN# CJ117, MAC PN# PP7185M or it's equivalent) to remove powersteering pulley. Remove the three bolts holding the powersteering pump to the bracket, do not remove hoses from PS pump. Remove the four bolts holding the powersteering and alternator bracket to the engine and remove the bracket.
4. Install the new alternator and pump bracket (4) onto the engine using bolts with lockwashers (9,10,11). Bolt the powersteering pump onto the new bracket using the O.E.M. bolts. Install the powersteering pulley onto the powersteering pump using a pulley installation tool, (Snap On PN# CJ113B, Mac PN# PP7005M or it's equivalent). Install the alternator onto bracket (4) using O.E.M. bolts. Install O.E.M. serpentine belt.  
**NOTE:** Since the alternator location was altered, the O.E.M. belt will fit slightly tighter. On trucks not equipped with A/C, it may be necessary to loosen the three bolts holding the O.E.M. idler in order to install the factory serpentine belt.
5. Install clutch pump (25) onto plate (5) with countersunk bolts (23). Install pump and plate onto pump bracket using bolts (12-15) provided. Align clutch pulley to crankshaft pulley (1), tighten plate bolts securely.  
**NOTE:** Due to a new air cleaner duct design change by Ford, some interference may be encountered when installing a hydraulic clutch pump. If this occurs, use a hot air gun to heat the cover and form it away from the pulley about 1/2 inch. Align clutch pulley to crankshaft pulley (1), tighten plate bolts securely.
6. Install pump belt idler tensioner (6) onto pump bracket (4) using bolt (7-8). Using bolt (19) and shims (18), properly align the idler pulley (17) with the drive pulley (1) and clutch pump pulley. **NOTE:** Use Locktite on bolt (19).
7. Install pump belts (24) as shown in diagram, check for proper belt alignment. Tighten belts with tensioner, using flat wrench (22), torque bolt (19) to 80 ft. lbs.
8. Install the fan and fan shroud. Install the upper radiator hose according to the attached sheet. Replace the radiator reservoir, tire wrench and jack tools. Reconnect the battery cables. Run the engine and check for proper belt tracking and clearance to all moving parts.

**CAUTION:** Check all engine compartment vacuum hoses and electrical wiring that may have been disturbed or re-routed during kit installation to be sure that hoses are not kinked, that they do not touch any high temperature item, and that they do not interfere with any linkage components.

## FMK 66 -2 Belts

1999-2003 Ford Truck 250-550

7.3D.I.T. Intercooled Diesel

W-WO/AC/Dual Alternator

**CAUTION:** Due to limited space available in the engine compartment, the pump is mounted directly under the hood light. Check clearance between the light and the pump before closing the hood. If there is not enough clearance, relocate the hood light to provide clearance.

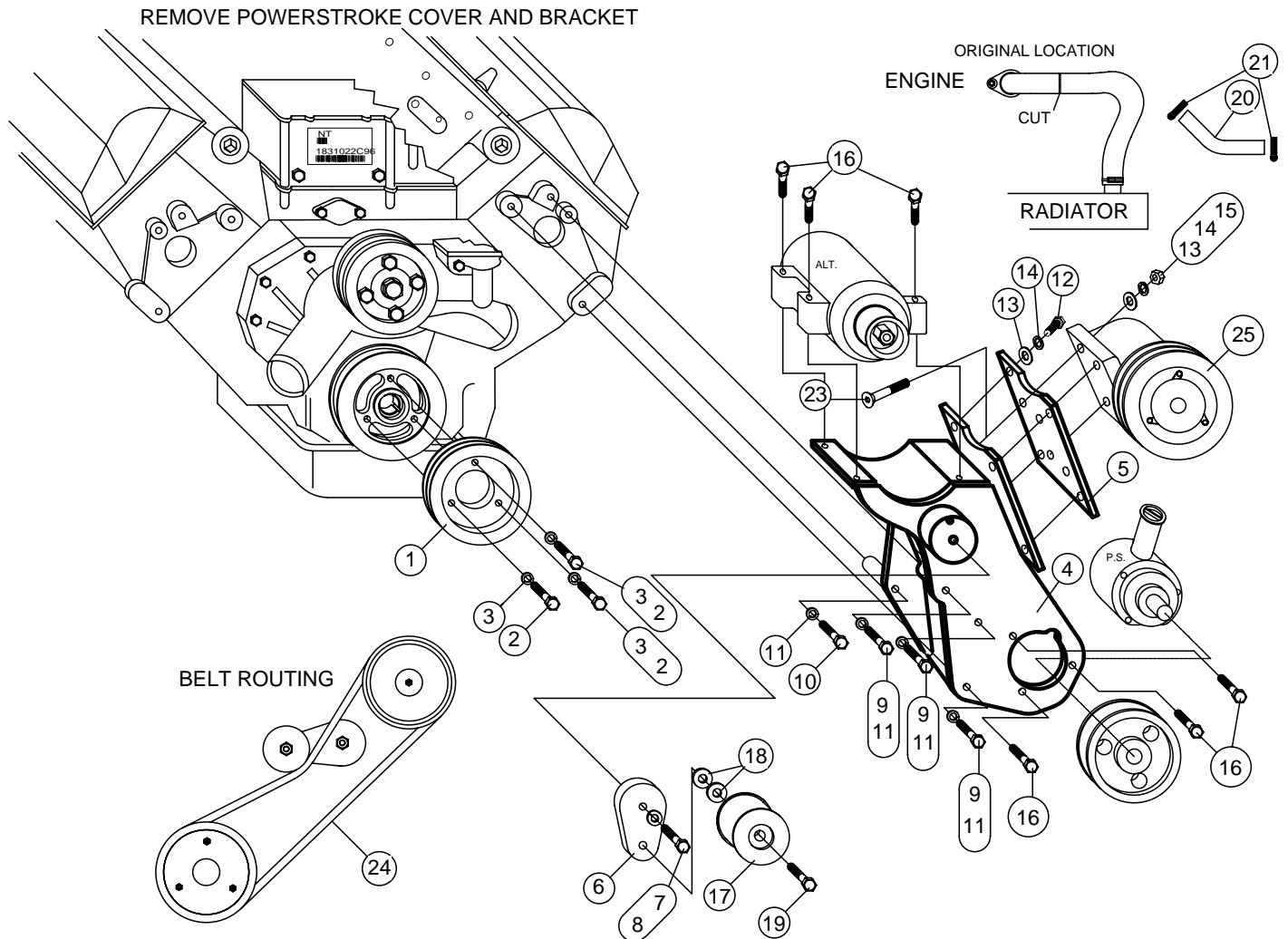

### PARTS LIST

1. FPC 65212 (1)
2. 10mm x 40mm 1.5 (3)
3. 10mm LW (3)
4. FMB 660 (1)
5. FMP 66(0-4) (1)
- IPKD66L Assembly (items 6-8 & 17-19)
6. FMB 661L (1)
7. 12mm x 45mm 1.75 (1)
8. 12mm LW (1)
9. 10mm x 140mm 1.5 (3)
10. 10mm x 80mm 1.5 (1)
11. 10mm LW (4)
12. 3/8 x 1 NC (4)
13. 3/8 FW (4)
14. 3/8 LW (4)
15. 3/8 NC Nut (2)
16. O.E.M.
- IPKD-25L Assembly (items 17-19)
17. IPCD Idler (1)
18. IPW 14 Shim (4)
19. 17mm x 2 1/2 Left hand thread (1)
20. F66 Rad. Line (1)
21. #28 Clamp (2)
22. 1" Wrench (1) (Not Shown)
23. Flat Socket Pump Bolts
24. Belts (2) (Not Shown)  
Goodyear 84710 (A69F)  
#2 Goodyear 84700 (A68F)  
#4 Goodyear 84690 (A67F)
25. Clutch Pump Assembly  
(Sold Separately)