



CW MILL EQUIPMENT CO., INC.
P.O. Box 246 • Sabetha, Kansas 66534
(785) 284-3454 • FAX (785) 284-3601

FMK 84A-8
2004-07 Ford F 650 & F750
Diesel VT 365
W-W/OAC
W/O Air Compressor

INSTALLATION NOTES

1. Install drive pulley (1) onto harmonic balancer using bolts (2) and lockwashers (3). Torque bolts to 40 ft.lbs..
2. Install bracket (4) on the front of the driver side head at locations "A", "B", and "C" with bolts (5) and lockwashers (3). Torque bolts to 40 ft.lbs..
3. Install clutch pump (11) onto the bracket with bolts (8), lockwashers (9), and nuts (10). Install coil and clutch as per manufacturer's instructions. Tighten bolts securely. Install tensioner (6) with bolt (7). Install belt (8) as shown in diagram.
4. Make certain any hoses, wires, etc. that were disturbed or relocated during installation have been properly secured out of the way of any hot or moving parts. Run engine and check for proper belt tracking and clearances.

FMK 84A-8

2004-07 Ford F650 & F 750

Diesel VT 365

W-W/O AC

W/O Air Compressor

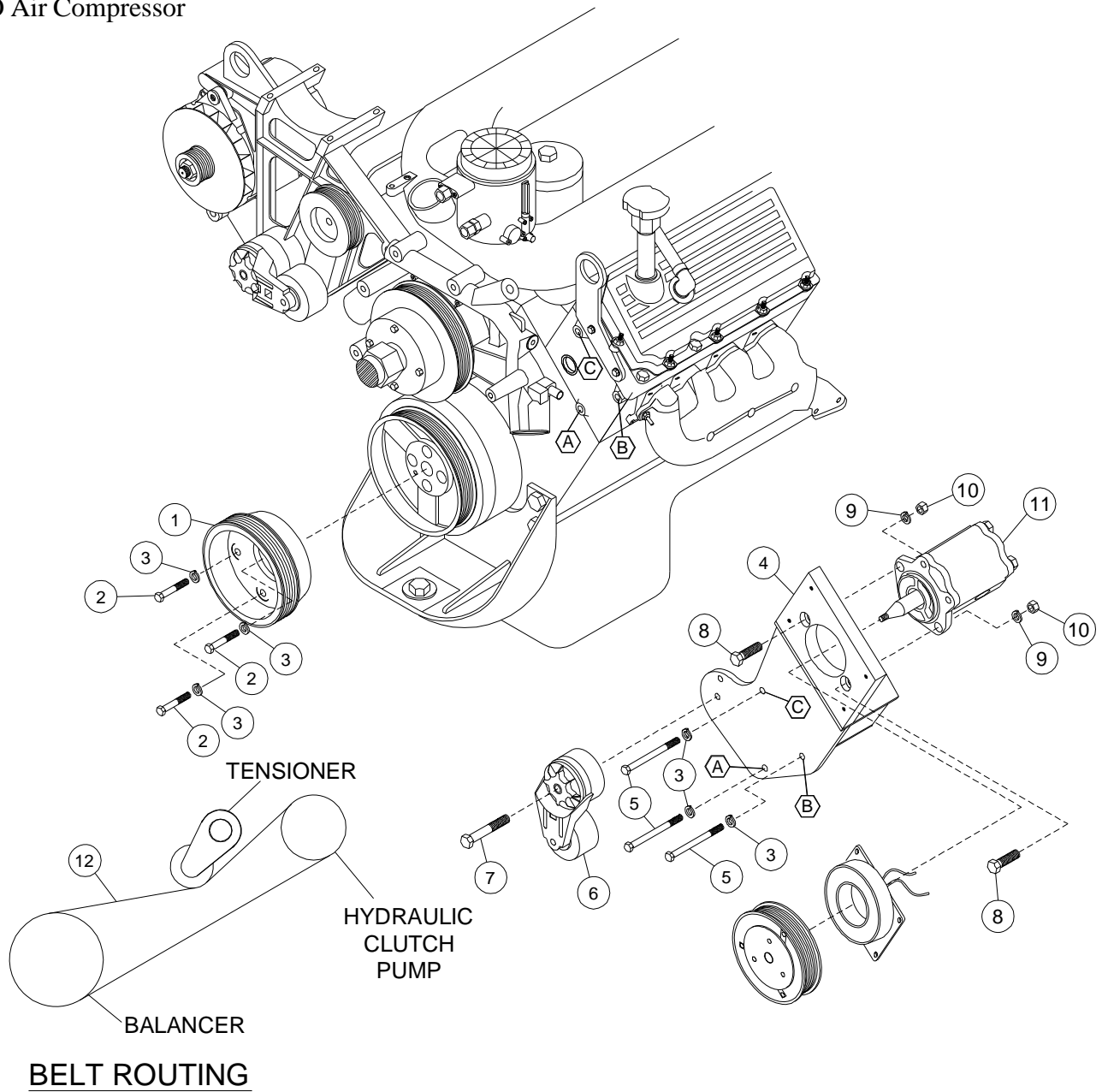

PARTSLIST

- | | |
|-------------------------|---|
| 1. FPC 688 (1) | 8. 3/8 x 1 1/2 NC (2) |
| 2. 10mm x 30mm (3) | 9. 3/8 LW (2) |
| 3. 10mm LW (6) | 10. 3/8 Nut NC (2) |
| 4. IMB 63A (1) | 11. Clutch Pump Assembly
(Sold Separately) |
| 5. 10mm x 150mm (3) | 12. Belt; Dayco 5080630 (1) |
| 6. Tensioner 89200B (1) | |
| 7. 10mm x 75mm (1) | |