



CW MILLEQUIPMENT CO., INC.
P.O. Box 246 • Sabetha, Kansas 66534
(785) 284-3454 • FAX (785) 284-3601

FMK 91 -2 Belts

2000-01 Ford Truck 650 & 750

CAT 3126, W-WO/AC

with engine serial #8YL82468 & lower

INSTALLATION NOTES

1. Disconnect negative battery cable. Drain the coolant from the radiator and remove the 1" diameter hose from the upper radiator tank. Remove the air intake tube at the air cleaner and the radiator. Remove the fan with a 1 3/4" and 1 7/8" wrench. Threads are left handed. Remove the O.E.M. serpentine belt, it will not be reused. Remove the six bolts from the fan idler pulley, remove the pulley and replace it with the pulley (1) from the kit. Reuse the O.E.M. pulley bolts to install the new pulley.
2. Remove the alternator and both of the alternator brackets. Loosen the two bolts underneath the A/C compressor and swing it outwards. Using the six bolts (15) and lockwashers (14) install the hydraulic pump bracket to the engine using the same holes that held the alternator brackets in place. Tighten bolts. Install the brace with the slotted holes to the back of the bracket using bolt (15), lockwashers (14) and nut (16). To the engine just above the exhaust manifold, use bolt (13) and lockwasher (14). It will be necessary to bend the metal tab that keeps the exhaust bolts from turning down. Tighten bolts evenly.
3. Install the alternator into the new bracket using the O.E.M. bolts and slide bushing. Pivot the A/C compressor out until the hole at the bottom of the bracket aligns with the hole on the compressor. Install O.E.M. bolt and tighten bolts at all three locations.
NOTE: It may be necessary to bend the A/C/ lines so that the compressor can swing out far enough. Install the serpentine belt that came in the kit using O.E.M. belt routing.
4. Install the pump plate onto the bracket using bolts (23 & 24), lockwashers (21), nut (22), and adjustment slide (5) with the slot to the top. Install the pump onto the plate with the bolts provided, align clutch pulley with the drive pulley and tighten bolts. Install the pump belts and tension properly using the jack bolt. Tighten jam nut. Replace the fan. Replace the 1" diameter hose from the truck with the longer hose from the kit. Use O.E.M. clamps and make sure the hose does not come in contact with clutch pump pulley. Replace the air duct. It may be necessary to heat the air tube where it passes the back of the pump and push it in to provide enough clearance. Replace antifreeze. Connect battery cable.

CAUTION: Check all engine compartment vacuum hoses and electrical wiring that may have been disturbed or re-routed during kit installation to be sure that hoses are not

FMK 91 -2 Belts

2000-01 Ford Truck 650 & 750

CAT 3126, W-WO/AC

with engine serial #8YL82468 & lower

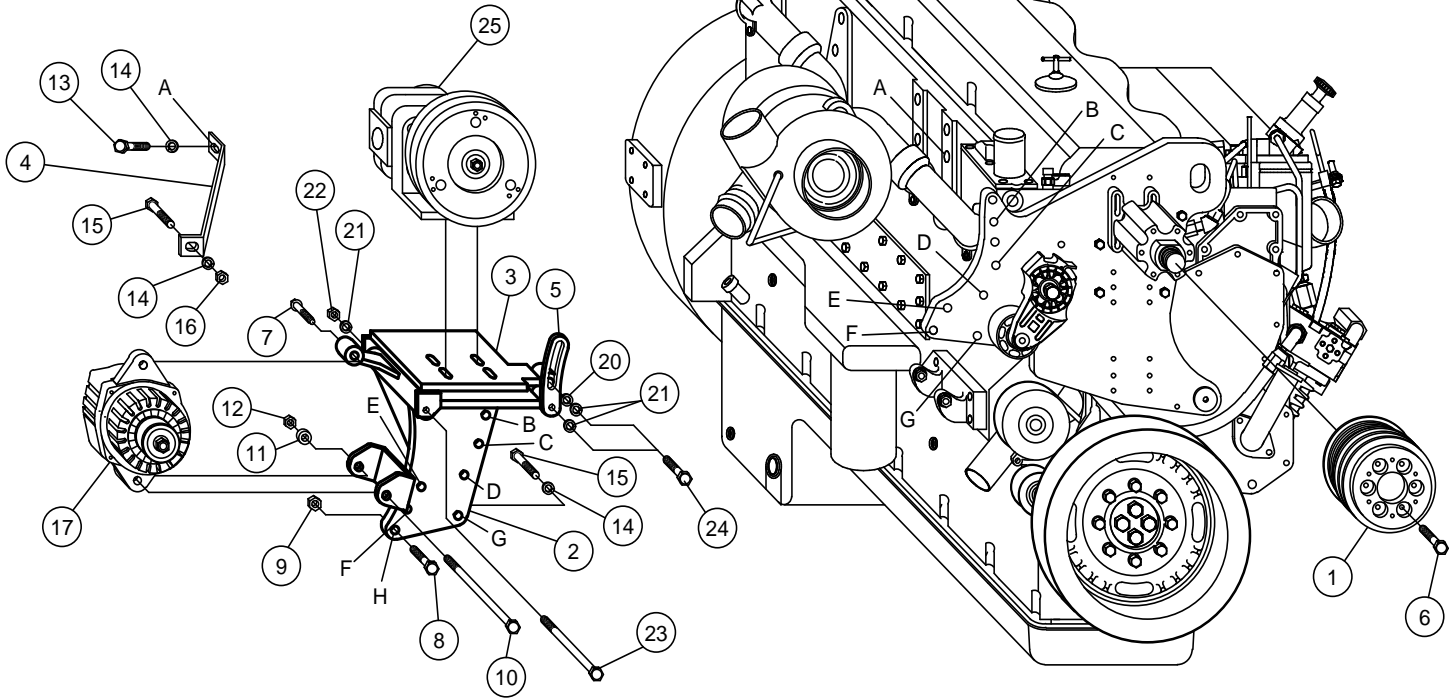

PARTS LIST

- | | |
|-----------------------------|--|
| 1. FPC 912 (1) | 23. 3/8 x 6-1/2 NC (1) |
| 2. FMB 910 (1) | 24. 3/8 x 1-1/4 NC (2) |
| 3. FMP 91(0-4) (1) | 25. Clutch Pump Assembly
(Sold Separately) |
| 4. FMB 911 (1) | 26. Acc. Drive Belt (Not Shown) (1)
Dayco 5080830 |
| 5. FMB 912 (1) | Pump Belts (Not Shown) (2)
Dayco AX-46
#2 AX-45, #4 AX-44 |
| 6. OEM Fan Pulley Bolts (6) | 27. 1" heater hose (Not Shown) |
| 7. OEM Alternator Bolt (1) | 28. <u>A/C Bracket Assembly (Not Shown)</u>
<i>Required for trucks without a/c.</i> |
| 8. OEM Bolt (1) | FMB 913 (1) |
| 9. OEM Nut (1) | 3/8 x 1 1/2 NC (2) |
| 10. OEM Bolt (1) | 3/8 LW (2) |
| 11. OEM Bushing (1) | 3/8 NC Nut (2) |
| 12. OEM Nut (1) | Instruction Card (1) |
| 13. 10mm x 25mm Bolt (1) | |
| 14. 10mm LW (8) | |
| 15. 10mm x 30mm Bolt (7) | |
| 16. 10mm Nut (1) | |
| 17. OEM Alternator (1) | |
| 20. 3/8 FW (1) | |
| 21. 3/8 LW (3) | |
| 22. 3/8 NC (1) | |

NOTE: With 7" clutch #2 AX-46, #4 AX-45.