



CW MILL EQUIPMENT CO., INC.
P.O. Box 246 • Sabetha, Kansas 66534
(913) 284-3454 • FAX (913) 284-3601

IMK 32 -2 Belts
1989-93 International
DTA360 ,W-WO/PS,HD Alt.
WO/AC, WO/Air Brakes

INSTALLATION NOTES

1. Disconnect battery terminal. Remove front lifting lug from cylinder head on driver's side - location "C". If equipped with air or vacuum pump, remove belt. Remove the two 3/8 in. bolts on front of water pump - locations "A & B".
2. Mark location of fan hub to inside pulley for proper re-installation. Remove fan and outside pulley, replace pulley with drive pulley (14) using O.E.M. bolts. Re-install fan aligning marks. Secure fan.
3. Install bracket (3) with bolts (7) at location "A & B", do not tighten bolts. Bolt bracket (1) to bracket (3) with bolts (9) and to cylinder head with bolt (4), tighten bolts at all locations.
4. Install pump plate (2) and pump with bolts (6 & 9). Make sure clutch pulley is in line with two grooves on water pump pulley closest to fan, tighten pump. Install jack-screw (10) to pump plate.
CAUTION: Check clearance between fan and clutch pump.
5. Install two pump drive belts (16) and adjust pump plate (2) for proper belt tension using jackscrew. Tighten bolts (6 & 9) on pump plate. Connect battery terminal.

CAUTION: Check all engine compartment hoses and electrical wiring that may have been disturbed or re-routed during kit installation to be sure that hoses are not kinked, that they do not touch any high temperature item, and that they do not interfere with any linkage components.

NOTE: Radiator hose on some older models may need re-routed for clearance around clutch pump.

IMK 32 -2 Belts

1989-93 DTA360 INTERNATIONAL

W-WO/P.S., H.D. ALT.

WO/AC, WO/AIR BRAKES

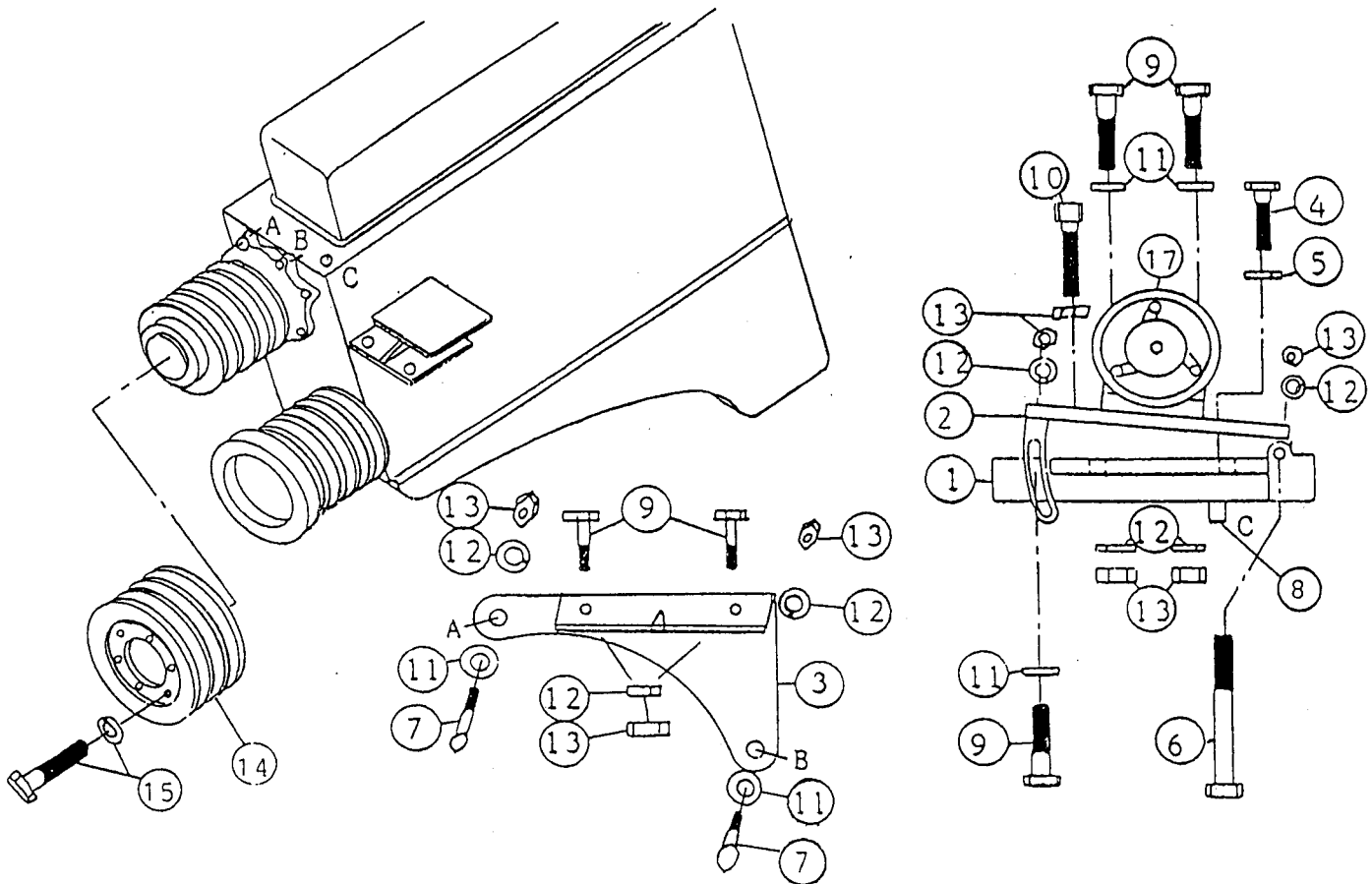

PARTS LIST

- | | |
|--------------------------|---|
| 1. IMB 310 (1) | 9. 3/8 X 1 1/4 NC (6) |
| 2. IMP 31(0-4) (1) | 10. 3/8 X 3 1/2 SQ. (1) |
| 3. IMB 311 (1) (Notched) | 11. 3/8 FW (7) |
| 4. 9/16 X 3 NC (1) | 12. 3/8 LW (10) |
| 5. 9/16 LW (1) | 13. 3/8 NC (11) |
| 6. 3/8 X 4 1/2 NC (1) | 14. IPC 432B (1) |
| 7. 3/8 X 2 NC GR. 8 (2) | 15. O.E.M. |
| 8. SP165 X 1.937 (1) | 16. AX-44 (Not Shown) (#2-AX-43,#4-AX-42) |
| | 17. Clutch Pump Assembly (1) |
| | (Sold Separately) |

NOTE: With 7" Clutch AX-46, #2 AX-45, #4 AX-44.