



CW MILL EQUIPMENT CO., INC.
P.O. Box 246 • Sabetha, Kansas 66534
(785) 284-3454 • FAX (785) 284-3601

IMK 46 -2 Belts

1994-2001 International
DT408 & 466, WO/AC
(Serpentine)

INSTALLATION NOTES

1. Disconnect battery. Remove engine lifting lug on passenger side of cylinder head.
2. Install bracket (4) with bolts and lockwashers (7 & 8) into holes "A & B". Install bracket (5) using O.E.M. bolts into holes D & C on the engine and the two holes on the upper right side of bracket (4) using bolts, nuts & lockwashers (11,13 & 14). Tighten all bolts securely.
3. Remove cooling fan and serpentine drive belt. Remove the six bolts from the fan pulley. Using bolts and lockwashers (2 & 3) install pulley (1) over fan pulley and tighten. Install serpentine belt.
4. Install pump (16) onto plate (6), **do not tighten bolts**. Install pump and plate assembly onto bracket (4) and align the pump pulley with drive pulley (1). Tighten pump to plate bolts. Install and tighten pump drive belts.
5. Install fan and check for proper clearance with hoses, wires, radiator. Reconnect battery.

CAUTION: Check all engine compartment hoses and electrical wiring that may have been disturbed or re-routed during kit installation to be sure that hoses are not kinked, that they do not touch any high temperature item, and that they do not interfere with any linkage components.

IMK 46 -2 Belts

1994-2001 DT408 & 466 INTERNATIONAL
WO/AC (SERPENTINE)

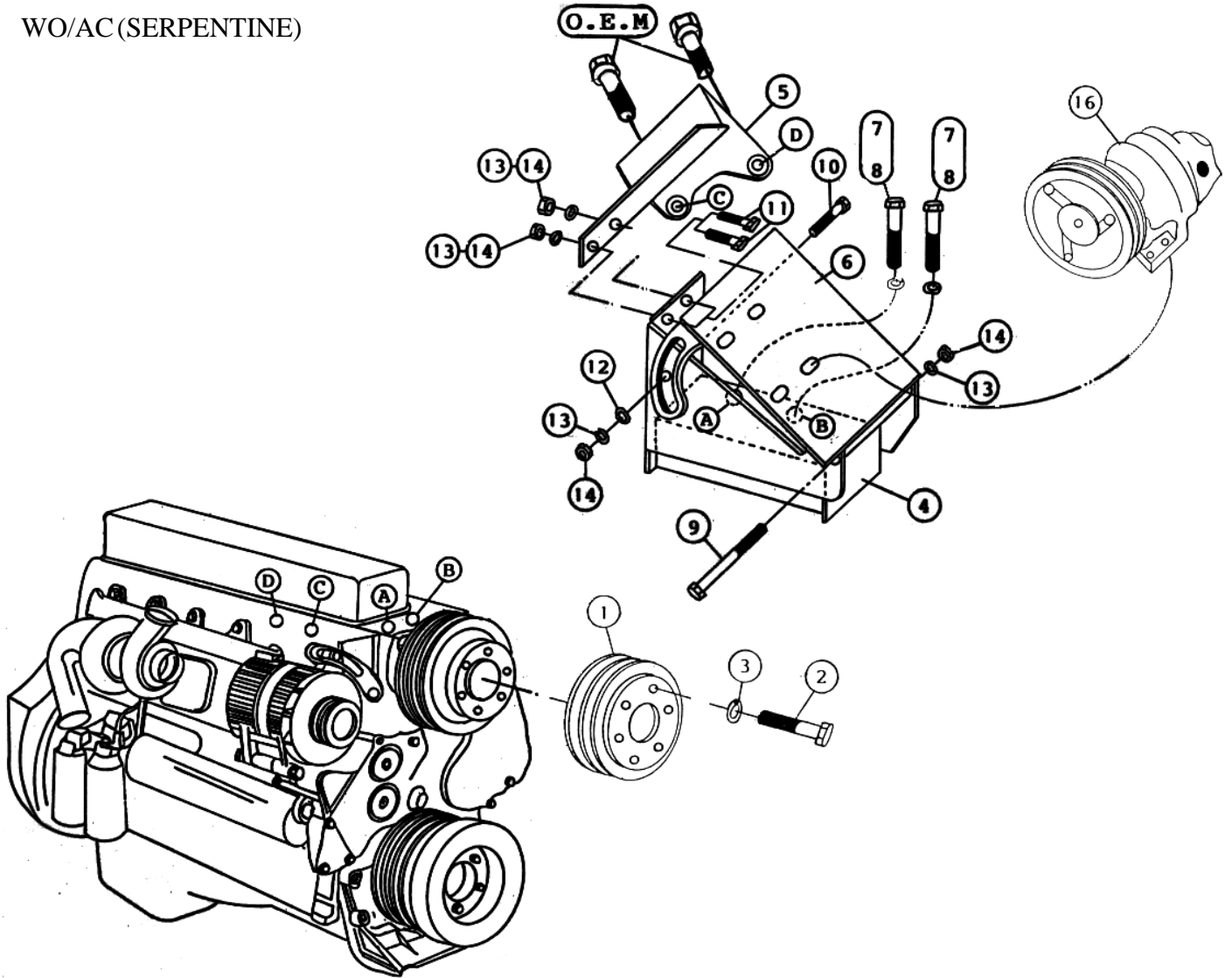

PARTS LIST

- | | |
|-------------------------|--|
| 1. IPC 462 (1) | 10. 3/8 x 1 1/2 NC (1) |
| 2. 8mm x 30mm 1.25 (6) | 11. 3/8 x 1 NC (2) |
| 3. 8mm LW (6) | 12. 3/8 FW (1) |
| 4. IMB 460 (1) | 13. 3/8 LW (4) |
| 5. IMB 461 (1) | 14. 3/8 NC Nut (4) |
| 6. IMP 46(0-4) (1) | 15. A46F Goodyear (2) (Not Shown)
(#2 A45F,#4 A44F) |
| 7. 12mm x 65mm 1.75 (2) | 16. Clutch Pump Assembly (1)
(Sold Separately) |
| 8. 12mm LW (2) | |
| 9. 3/8 x 5 NC (1) | |

NOTE: With 7" #2 A46F, #4 A45F.