



CW MILL EQUIPMENT CO., INC.  
P.O. Box 246 • Sabetha, Kansas 66534  
(785) 284-3454 • FAX (785) 284-3601

## **IMK 52A-I8 Belt**

**2005-07 International  
7400  
DT466, 530  
4-bolt Alternator  
W-/AC**

### **INSTALLATION NOTES**

---

1. Disconnect the negative battery cable. Remove the passenger side inner fender. Remove the turbo cooler tube. Remove the accessory drive belt. Disconnect the alternator wires and remove the alternator and the alternator bracket. The alternator and alternator bracket bolts will be reused.
2. Install the alternator onto the new bracket (1) as shown in the illustration. Torque the bolts to 35 ft/lbs. Install the alternator and bracket assembly onto the engine at the OEM alternator bracket location reusing the OEM bolts. Torque the 10mm bolts to 40-45 ft/lbs, and the 8mm bolts to 25-28 ft/lbs. Install the clutch pump onto the bracket with bolts (7), flatwashers (8), lockwashers (9), and nuts (10). Torque the nuts to 35 ft/lbs. Install the coil and clutch per manufacturer's instructions.
3. Install idler (3) onto the bracket with bushing (2), flatwasher (4), and bolt (5). **DO NOT TIGHTEN**. Install the new belt (10) onto the engine according to the belt diagram. With the tensioner arm rotated and the belt in place, slide the idler (3) as far inward as possible and tighten bolt (5) before releasing the tensioner.
4. Reconnect the alternator wires. Remove the steel band from the 3-1/2" end of the cooler tube, being careful not to damage the rubber coupler as it will be reused. Install the 3-1/2" OEM rubber coupler onto the end of the new tube (11), and the 3" 45° elbow (12) onto the other end. Install the two hose clamps (14) onto the 45° elbow and clamp (13) along with the OEM clamp onto the straight OEM coupler. Do not tighten. Install the cooler tube assembly onto the engine and position it for the best fit and clearance. then tighten the hose clamps securely. Install the inner fender and reconnect the battery cable.
5. Check that hose(s) and wire(s) have clearance from hot or moving parts. Run the engine to make sure the belt tracks properly and tension is correct.

**IMK 52A-I8**  
**2005-07 International**  
**7400**  
**DT466, 530**  
**4-bolt Alternator**  
**W/AC**

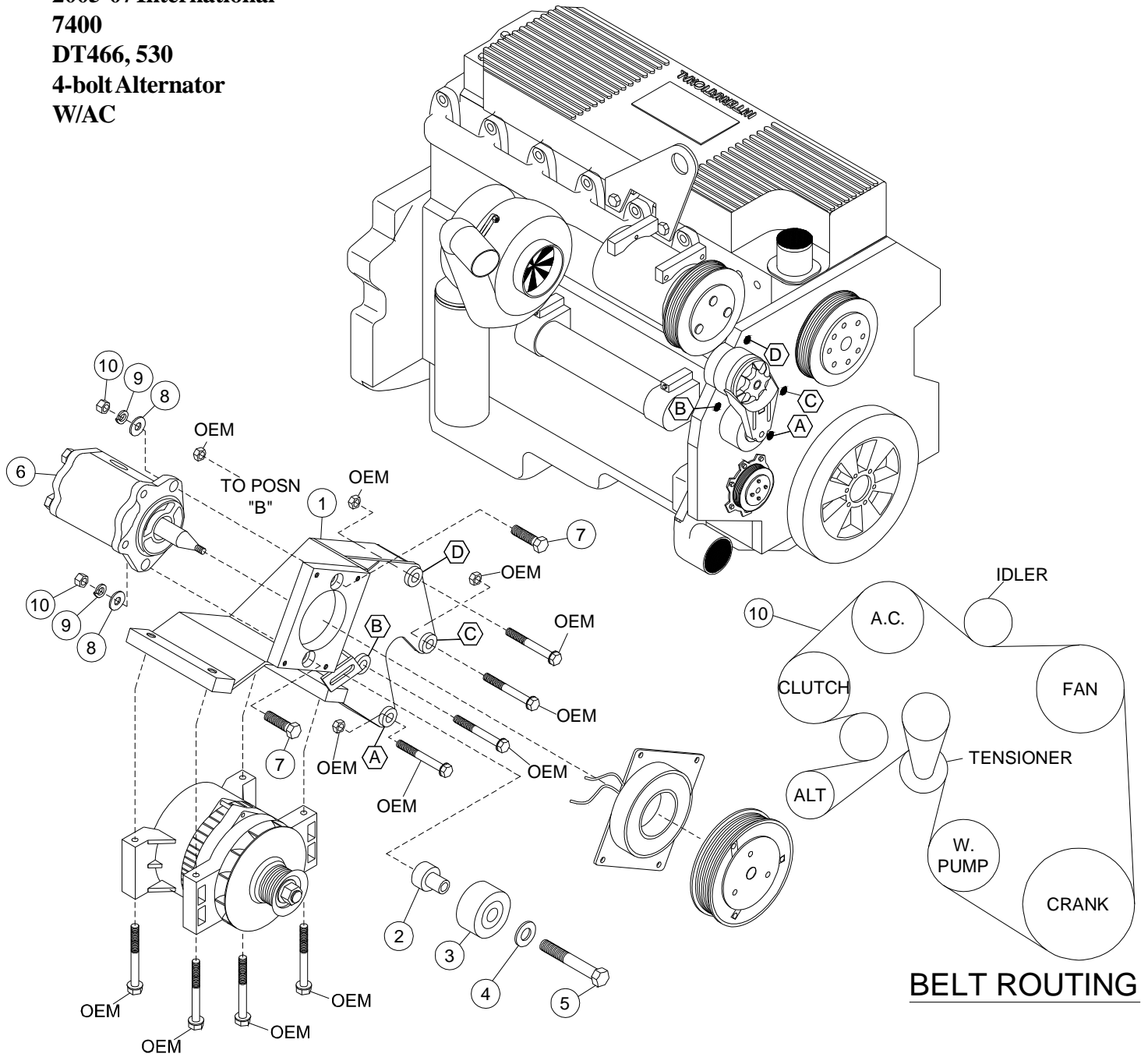

**PARTS LIST**

- |                             |                             |
|-----------------------------|-----------------------------|
| 1. IMB 490 (1)              | 8. 3/8 FW (2)               |
| 2. IMB 491 (1)              | 9. 3/8 LW (2)               |
| 3. IPCD 2.75 (1)            | 10. 3/8 Nut (2)             |
| 4. 12mm FW (1)              | 11. 5081125 Dayco (1)       |
| 5. 12mm x 65mm (1)          | 12. ST 39035 Steel Tube (1) |
| 6. Clutch Pump Assembly (1) | 13. TP1487000 45° Elbow (1) |
| (Sold Separately)           | 14. 250-92 Clamp (1)        |
| 7. 3/8 x 1-1/2 Bolt (2)     | 15. 250-84 Clamp (2)        |

***NOTICE:***

**Due to O.E.M. belt length variation, the belt supplied in this kit may not be the right length for your application. If a different length belt is needed, the installer can purchase a belt locally or exchange it for a different length belt from CW Mill Equipment, with the installer being responsible for the freight charge.**

.....

***NOTICE:***

**Due to O.E.M. belt length variation, the belt supplied in this kit may not be the right length for your application. If a different length belt is needed, the installer can purchase a belt locally or exchange it for a different length belt from CW Mill Equipment, with the installer being responsible for the freight charge.**