

INSTALLATION NOTES

1. Disconnect the negative battery cable. Install drive pulley (1) onto the engine damper with bolts (2) and lock washers (3). Torque bolts to 35 ft. lbs.
2. Remove engine lifting lug from the front of the driver's side cylinder head.
3. Install pump bracket (4) with bolts (5) and lock washers (3). Torque to 35 ft. lbs.
4. Install pump (15) with bolts (12), lock washers (13) and nuts (14). Install coil and clutch per manufacture's instructions.
5. Install idlers (9) using bolts (11), flat washers (10) and idler spacers (8). Install belt tensioner (6) using bolt (7). Install the belt (16) as shown in the diagram on the back of this sheet. Reconnect the battery cable.

NOTE: Run engine and check for proper belt tracking and clearances.

IMK64A-8

2008-2016 International Dura Star

2011-2016 Terra Star

MAXXFORCE 7

W-W/O AC W/O Air Compressor

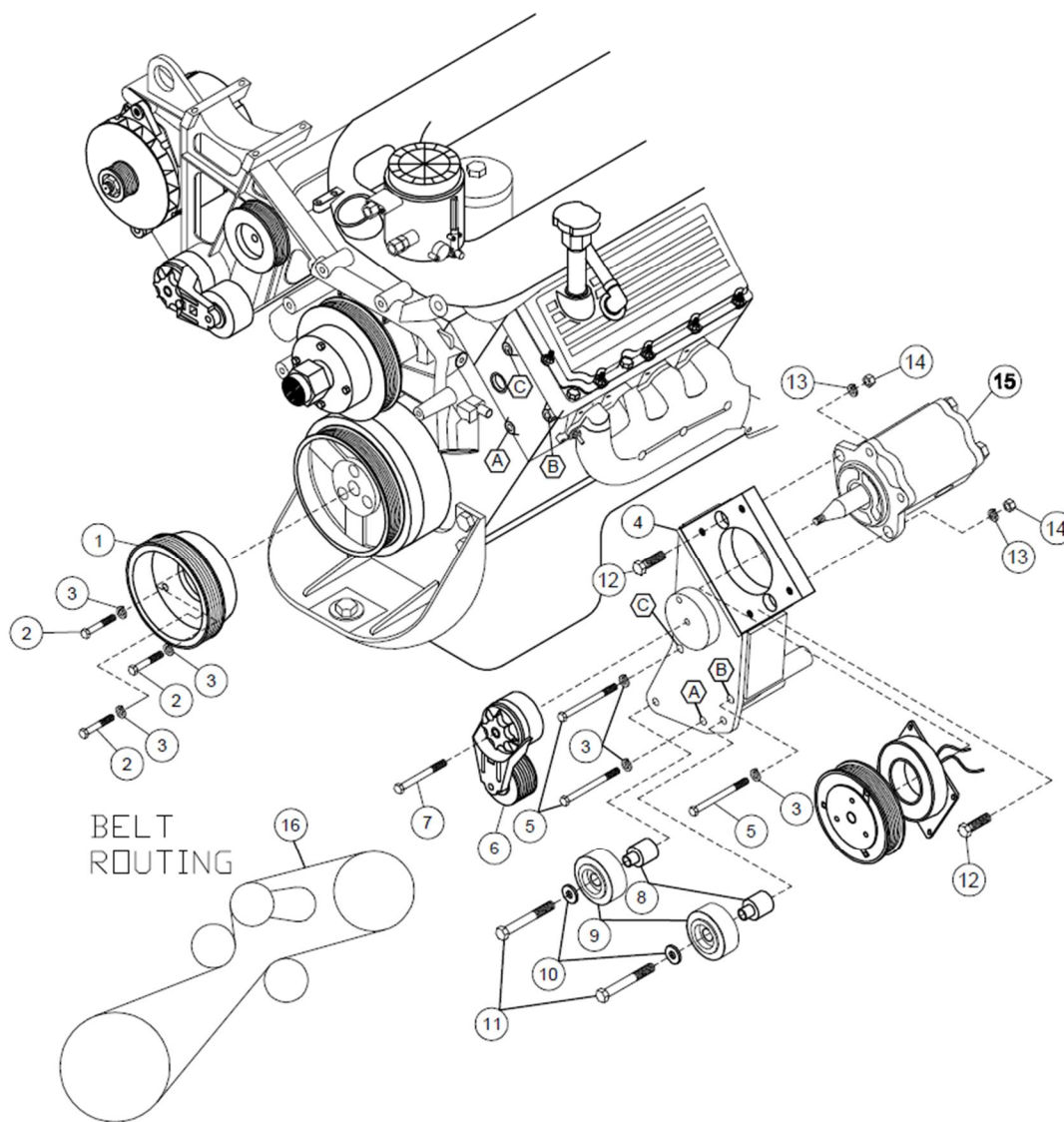

PARTS LIST

- | | |
|--------------------------------|--------------------------------------|
| 1. FPC 2608 (1) | 9. 89016 Idler (2) |
| 2. 10mm x 50mm Bolts (3) | 10. 12mm FW (2) |
| 3. 10mm LW (6) | 11. 12mm x 75mm Bolt (2) |
| 4. IMP 64A (1) | 12. 3/8 x 1-1/2 (2) |
| 5. 10mm x 150mm (3) | 13. 3/8 LW (2) |
| 6. 89438-53 Tensioner (1) | 14. 3/8 NC (2) |
| 7. 10mm x 80mm Flange Bolt (1) | 15. Pump (sold separately) |
| 8. IMB641 (2) | 16. Belt 5080670 (1) (5-1/2" Clutch) |