



CW MILL EQUIPMENT CO., INC.  
P.O. Box 246 • Sabetha, Kansas 66534  
(785) 284-3454 • FAX (785) 284-3601

**IPK 63A-I8**  
2003-07 International  
4200 Series, VT 365 Diesel  
W/O AC, W-W/O Air Brakes

---

## INSTALLATION NOTES

---

1. If equipped with an air compressor, remove the air compressor belt. Remove the accessory drive belt. Remove the grooved idler at location "A" and replace it with the flat idler (12), reusing the OEM idler hardware. Install mounting plate (1) with bolts (4) and tighten securely. Install A-mount adapter plate (2) to mounting plate (1) with bolts (5) and lockwashers (6). Do Not Tighten.
2. Install the clutch pump with bolts (9) flatwashers (10), lockwashers (6), and nuts (11). Tighten securely. Install the coil and clutch per manufacturer's instructions. Using a straight edge, make certain the clutch pulley is parallel with the OEM pulleys, then tighten bolts (5) securely. Install both gussets (3) using bolts (7) and lockwashers (8), then tighten bolts securely.
3. Install the new belt (16) onto the engine according to the belt diagram. If equipped with air compressor, install the air compressor belt. Check for clearances on all moving parts.

# IPK 63A-I8

2003-07 International

4200 Series

VT 365 Diesel

W/O AC

W-W/O Air Brakes

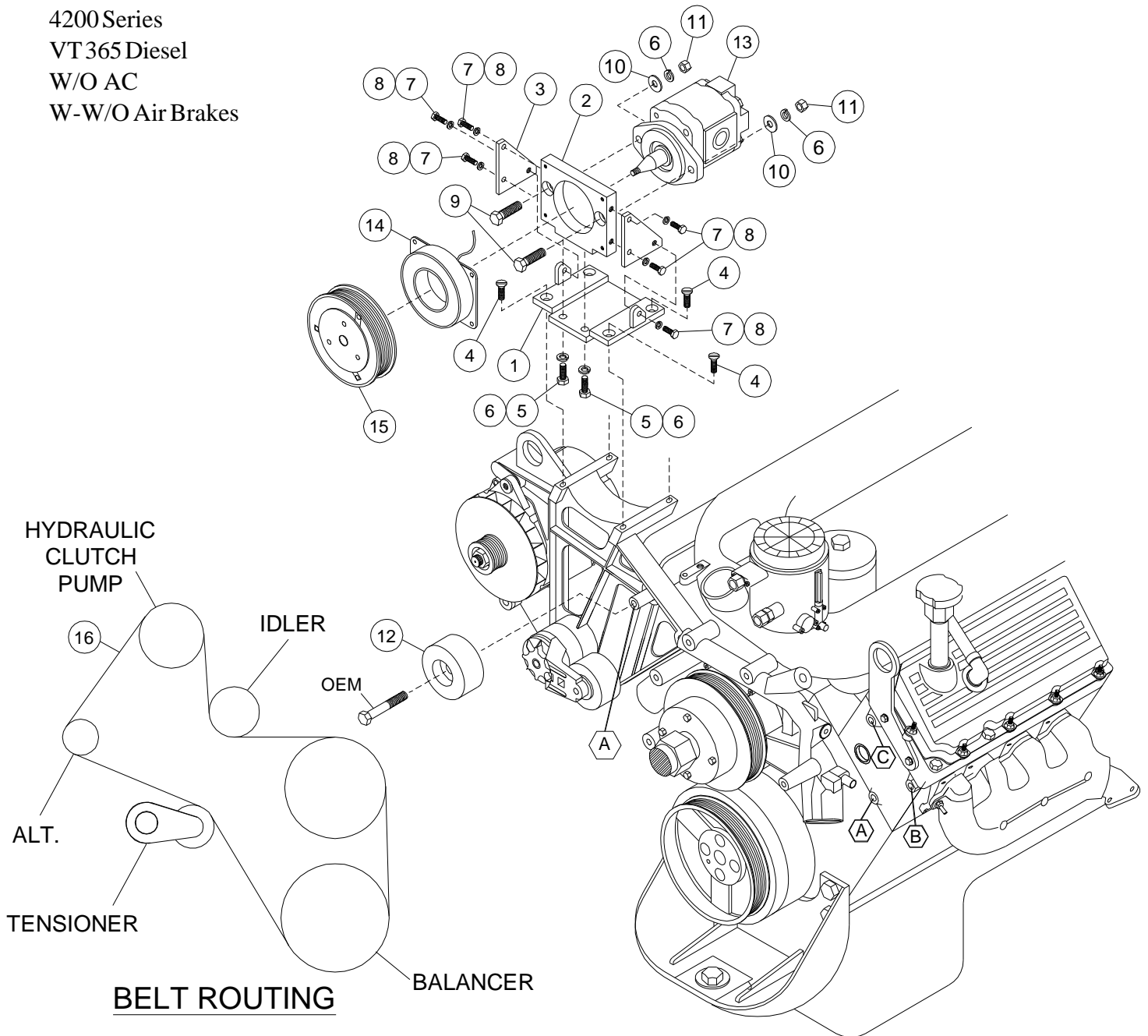

## PARTSLIST

- |                         |   |
|-------------------------|---|
| 1. IMP 63AI8 (1)        | 10. 3/8 FW (2)                                |
| 2. PBL2M (1)            | 11. 3/8 Nut (2)                               |
| 3. IMB63I81 (2)         | 12. IPCD Idler (1)                            |
| 4. 8mm x 50mm FHSCS (4) | 13. Clutch Pump Assembly<br>(Sold Separately) |
| 5. 3/8 x 1 Bolt (2)     | 14. Coil                                      |
| 6. 3/8 LW (4)           | 15. Clutch                                    |
| 7. 1/4 x 3/4 Bolt (6)   | 16. Belt; Dayco 5080855 (1)                   |
| 8. 1/4 LW (6)           |   |
| 9. 3/8 x 1-1/2 Bolt (2) |   |