

INSTALLATION NOTES

1. Disconnect the negative battery cables. Remove the lifting lug from the front of the cylinder head. Remove the three bolts holding the fan shroud ring to the engine. Push the aluminum ring forward. Remove the fan (fan nut has left hand threads) and set it inside the fan shroud. Be careful not to damage the radiator.
2. Install the drive pulley(1) onto the engine crank pulley with bolts(2) and lock washers(3). Install idlers(12) using bolts(14,17), flat washers(13,16), and bushings(11,15). Install pump into bracket(4) using bolts(21), nuts(22), lock washers(23) and flat washers(24). Install bracket(4) using bolts(5,7) and lock washers(6,8). Install clutch and coil per manufacturer's instructions. Install tensioner(18) using bolt(19). Install the drive belt(25) as shown in the diagram on the back. Install the fan spacer(20) followed by installing the fan. Reinstall the fan shroud ring reusing OEM hardware.
3. Reconnect the negative battery cable. Run engine and check for proper belt tracking and clearance of all moving parts.

MMK30A-8

2012-2016 MITSUBISHI FUSO

FE, FG, CANTER

3.0L DIESEL

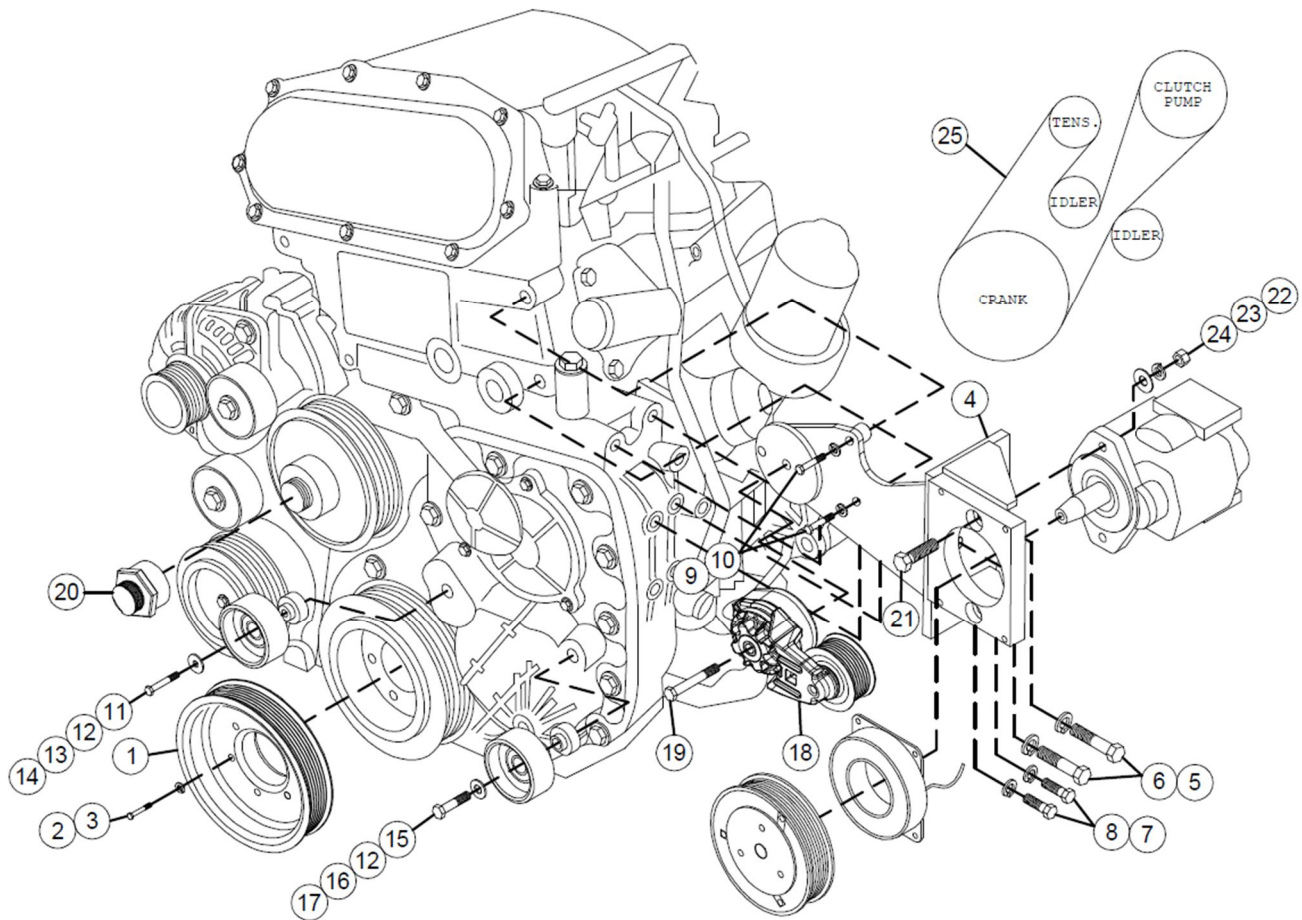

PARTS LIST

- | | |
|------------------------|-----------------------|
| 1. MPC308 (1) | 13. FMB483-I6 |
| 2. 6mm x 45mm (6) | 14. 8mm x 50mm (1) |
| 3. 6mm Lock Washer (6) | 15. MMB301 (1) |
| 4. MMP30A-8 (1) | 16. 3/8 FW (1) |
| 5. 12mm x 65mm (2) | 17. 10mm x 50mm (1) |
| 6. 12mm LW (2) | 18. 89200B-GPCD8 (1) |
| 7. 10mm x 35mm (2) | 19. 10mm x 80mm (1) |
| 8. 10mm LW (2) | 20. FSK30 (1) |
| 9. 8mm x 40mm (2) | 21. 3/8 x 1-1/2 (2) |
| 10. 8mm LW (2) | 22. 3/8 Nut (2) |
| 11. MMB302 (1) | 23. 3/8 LW (2) |
| 12. Dayco 89016 (2) | 24. 3/8 FW (2) |
| | 25. Dayco 5080725 (1) |