

INSTALLATION NOTES

1. Disconnect the negative battery cable. Remove the air cleaner assembly. (Draining the engine coolant and removing the upper radiator hose will make removing the fan shroud easier, but is not necessary). Remove the bolts from the top half of the fan shroud and remove it. Remove the fan assembly.

Fan nut has right hand threads

2. Remove the engine drive belt and tensioner. Remove the engine oil fill tube, dipstick tube, and the bracket from the front of the cylinder head. Remove the bolt from the harmonic damper and install the new pulley and pulley adapter (1, 2) with bolt (3) and set screws (5). Torque bolt (3) to 240 ft/lbs. Cross torque set screws (5) at 10 in/lbs, 5 ft/lbs, 15 ft/lbs, and then 25 ft/lbs

3. Install the main bracket (7) onto the engine at the OEM tensioner location using bolts (12,13) and lock washers (11). Torque bolts to 30 ft. lbs. Install the angle brace (8) into the front of the cylinder head and the back of the bracket using bolts (14). Tighten all four bolts lightly then torque them to 30 ft. lbs. Install the grooved idler (22) into the top hole of the main bracket using idler bushing (21) and bolt (23). Remove the three bolts from the alternator bracket just below the alternator. Install the new tensioner plate (9) with bolts (15). Install the tensioner (27) onto the bracket using bolt (26).

The O.E.M. belt needs to be behind the tensioner before it's tightened. Install the OEM belt.

4. Install oil fill tube standoff (10) using bolts (24). Install the clutch pump with bolts provided. Align clutch pump with drive pulley using a straight edge and tighten pump bolts. Install the clutch pump tensioner (25) using bolt (26). Install the pump drive belt (29). Fan shroud may need to be trimmed to clear aftermarket components. Install fan spacer nut (28) and fan. Never use an air hammer to remove or install the fan nut or clutch unless it is used with the appropriate tooling or water pump failure may occur. Make certain fan has adequate clearance. Replace fan shroud. Cut oil fill tube as shown in the illustration. Replace oil fill and dipstick tube securing them to standoff bracket (10) using wire loom clamps (19,20), bolt (16), nut (18), and lock washer (17). Replace upper radiator hose and engine coolant if removed. Replace air cleaner assembly.

5. Check all hoses, wires, etc. that were disturbed during the installation to make sure they do not come in contact with any hot or moving parts. Run engine and check for proper belt tracking.

VCK 39-6

2006-17 CHEVY VAN G1500-3500

4.8, 5.3, 6.0 VORTEC

W-WO AC

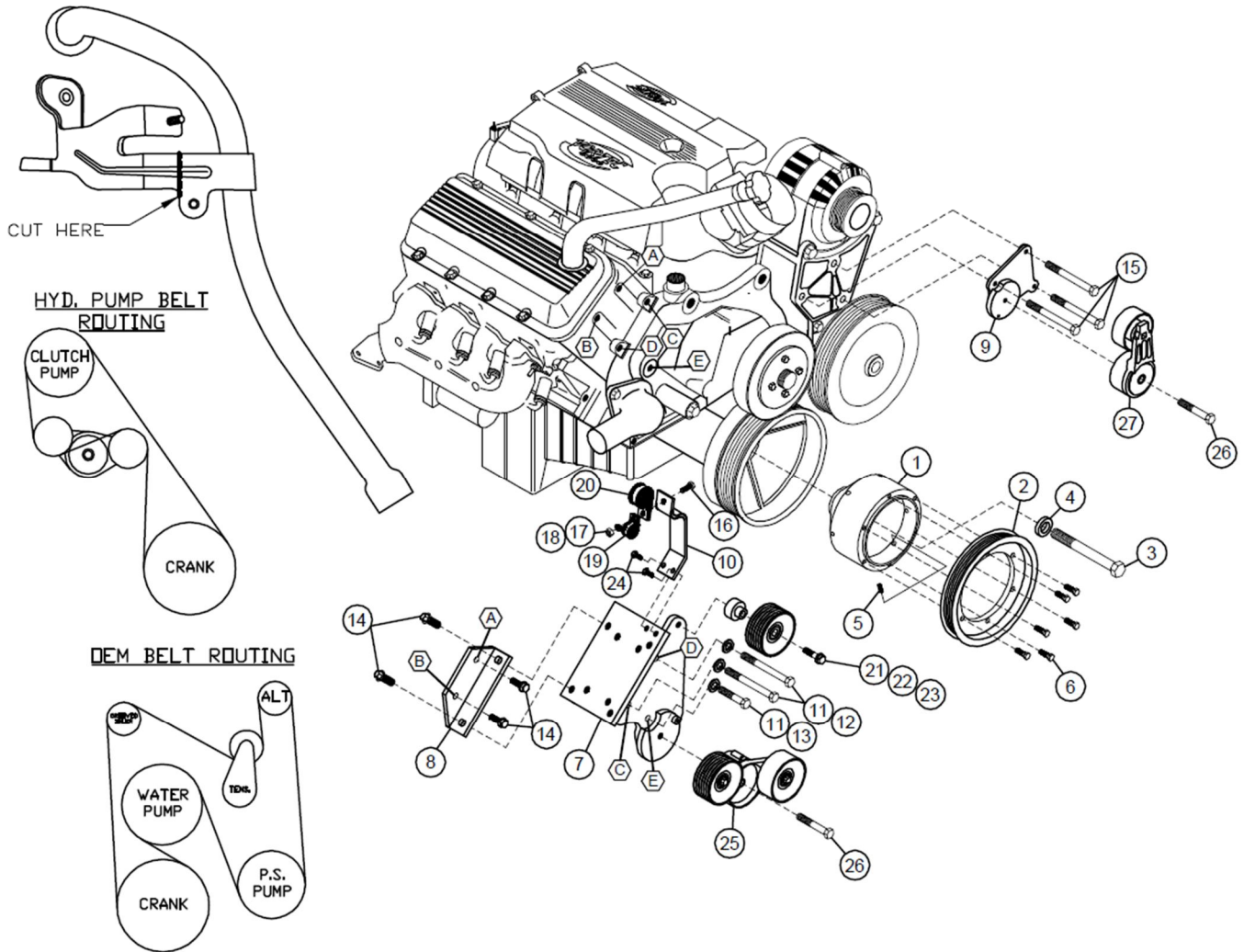

PARTS LIST

- | | |
|-------------------------------|----------------------------|
| 1. CPA382 (1) | 16. 1/4" x 3/4" (1) |
| 2. CPC386-7.5 (1) | 17. 1/4" Lock Washer (1) |
| 3. 16mm x 140mm (1) | 18. 1/4" Nut (1) |
| 4. 16mm FW (1) | 19. #14 Adel Clamp (1) |
| 5. 8mm x 20mm Set Screw (6) | 20. #16 Adel Clamp (1) |
| 6. 8mm x 25mm Flange Bolt (6) | 21. VCMB394 (1) |
| 7. VCMP39(0-4)-6 (1) | 22. 89051Dayco (1) |
| 8. VCMB391 (1) | 23. 10mm x 40mm Flange (1) |
| 9. VCMB392 (1) | 24. 8mm x 12mm Flange (2) |
| 10. VCMB393 (1) | 25. 89254-007 (1) |
| 11. 10mm LW (5) | 26. 10mm x 55mm (2) |
| 12. 10mm x 90mm (2) | 27. 89203-007 (1) |
| 13. 10mm x 50mm (1) | 28. FSK36R Fan Spacer (1) |
| 14. 10mm 20mm Flange Bolt (4) | 29. Dayco 5060555 (1) |
| 15. 10mm x 120mm (3) | |

MODIFICATIONS SHEET

