

INSTALLATION NOTES

1. Disconnect negative battery cable. Remove the top half of the fan shroud and the fan. (*Fan nut is right hand threads*). It's not necessary to remove the fan and fan shroud, but makes installation easier. Remove O.E.M. belt. Remove the hot wire from the back of the alternator, and the bracket that holds the wire connector to the alternator bracket.
2. Remove the three bolts holding the alternator bracket to the engine at locations A, B, & C. Install the compressor bracket (1) using those three hole locations on the alternator bracket with bolts (6) and lock-washers (7). (Do not tighten). Install aux. A.C. bracket brace (2) to the back of the pump bracket using bolts (8) & (9) and lock washers (7) at location D. Once all the bolts are in place and finger tight, tighten the front three bolts securely first and then the brace bolts.
3. Install the compressor (14) onto bracket (1) with bolts (10) in the front, and bolts (5) with nuts (11) and slide bushings (12) into the back. Install flat idler (4) into the lowest tapped hole on the front of the bracket that will allow the belt to be installed.
4. Replace the fan and top half of the fan shroud if removed. Connect the alternator wire. (*It may be necessary to splice in a piece of wire or replace wire with a longer one*). Connect battery and check to make sure all hoses, wire's, etc. are clear of any moving or hot parts.

NOTE: Check all engine compartment hoses and electrical wiring that may have been disturbed or rerouted during kit installation to be sure that hoses are not kinked, that they do not touch any high temperature items, and that they do not interfere with any linkage components.

CMK 38SD508-I6
1999-10 Chevy Silverado
2000-2014 Suburban, Tahoe
4.8,5.3,6.0
W-WO/AC

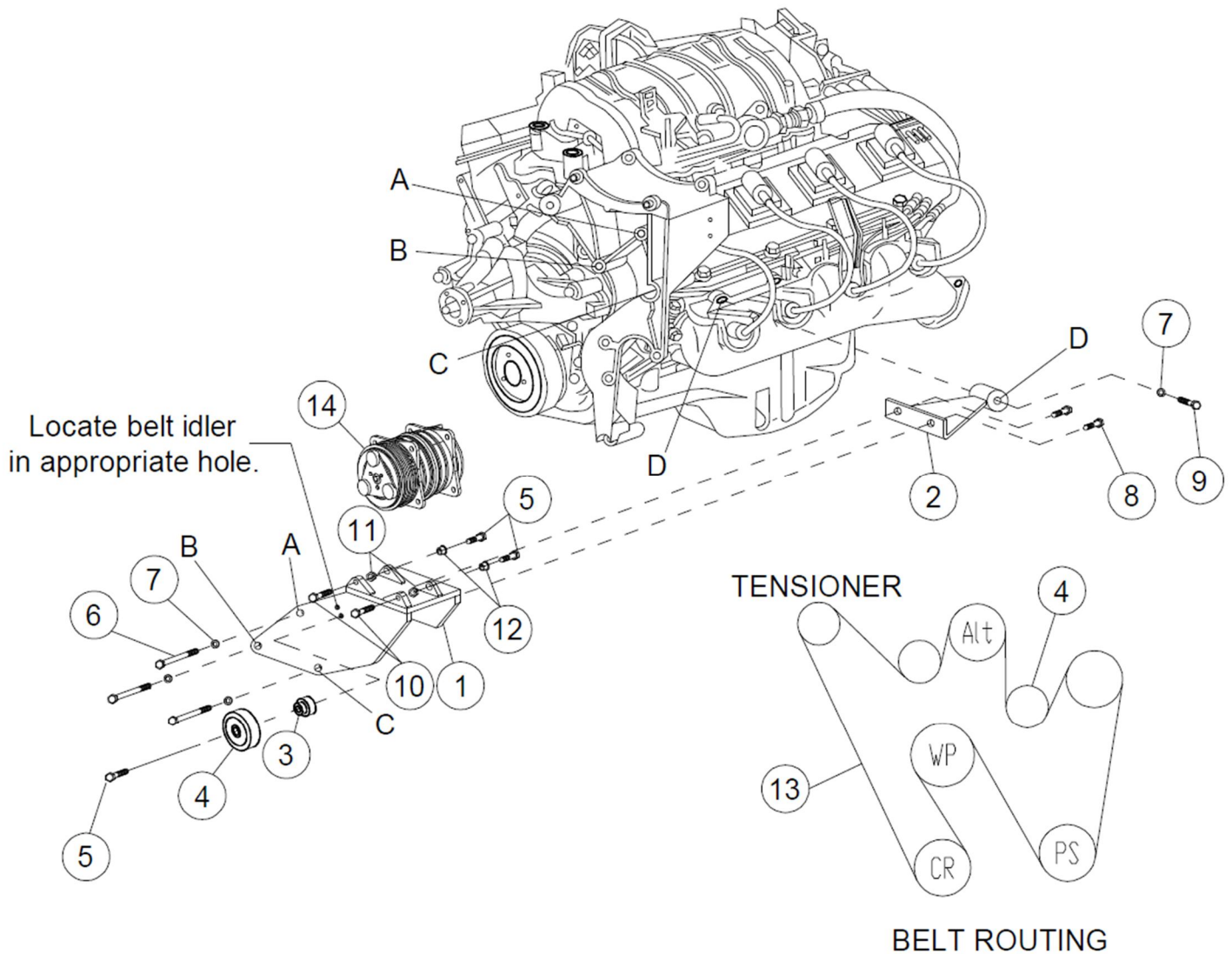

PARTS LIST

- | | |
|------------------------------------|--------------------------------------|
| 1. CMP38-SD508 (1) | 8. 10mm x 20mm 1.5 Flange (2) |
| 2. CMB 381 (1) | 9. 10mm x 60mm 1.5 (1) |
| 3. CMB3867(1) | 10. 10mm x 30mm Flange (2) |
| 4. 89007 Dayco Idler (1) | 11. 10mm Flange Nut (2) |
| 5. 10mm x 40mm 1.5 Flange Bolt (3) | 12. 1255-0090 Slide Bushing (2) |
| 6. 10mm x 140mm 1.5 (3) | 13. 5061150 Dayco Belt (1) |
| 7. 10mm LW (4) | 14. A/C Compressor (Sold Separately) |

BULLITEN

All 4.8, 5.3, and 6.0 liter engines will require the removal of aluminum from the O.E.M. alternator bracket in order for the aux. A.C. bracket to fit properly. The illustration shows the area that needs to be removed.

