



CW MILL EQUIPMENT CO., INC.
P.O. Box 246 • Sabetha, Kansas 66534
(785) 284-3454 • FAX (785) 284-3601

DMK40SD508-6
2009-2017 Dodge D-2500,3500
5.7L Hemi
W/WO AC

INSTALLATION NOTES

1. Disconnect the negative battery cable. Drain the engine coolant. Remove the air filter assembly from the engine compartment. The filter assembly is held on by two small bolts located under the fender well. Remove the antifreeze/windshield washer fluid reservoir from the fan shroud. Drain the windshield washer fluid from the tank. Remove the fan shroud and fan. (Fan nut has left hand threads) Remove the upper radiator hose from the thermostat housing then remove the thermostat housing. Reusing the bolts, install the new thermostat housing (19) onto the engine. Torque bolts to 20 ft. lbs.
2. Remove the bolt from the engine dampner. Using a cutoff wheel or other suitable tool, carefully cut the washer in half and remove it from the bolt. The bolt will be reused so be careful not to damage it. Install pulley (1) onto the front of the dampner with the O.E.M. bolt. Torque bolt to 135ft. lbs. Install set screws (2) into pulley (1) and run them in by hand until they all touch the dampner. Using a star pattern, tighten the set screws in 20 in.lb. increments to 100 in. lbs. A mild grade of loc-tite on the set screws is advisable.
3. Install bracket (3) onto the engine at locations A,B,C with bolts (4,5,6) and lockwashers (7,8). Torque bolts (4,5) to 25 ft. lbs. and bolt (6) to 35 ft lbs. Remove the nut at location D and replace it with coupler nut (15). Torque to 25 ft. lbs. Remove the bolt at location E and install stud (11) until it bottoms out in the hole then install bushing (12) onto the stud. Install the front bracket (9) with nut (13) at location E, bolt (14) at location D and bolts (10) into bracket (3). Torque nut and bolt (13, 14) to 25 ft lbs and bolts (10) to 35 ft. lbs.
4. Install the aux. A.C. compressor onto bracket (3) with bolts (24,25), nuts (26) and slide bushings (27). Install idlers (17) with bushings (16) and bolts (18). Torque idler bolts to 25 ft. lbs. Install tensioner (21) with bolt (22). Install the belt around the tenioner idler then torque the bolt to 30 ft. lbs. Install the aux. A.C. belt (23) and route as shown in the illustration. Replace the fan and fan shroud. Make sure there is adaqueate clearance (*1/4" minimum*) between the fan and the tensioner.
5. If installing on a 2009 vehicle use a heat gun, heat the windshild washer tank and compress it inward approximately 3/4" at the location shown in the illustration. Install the tank onto the fan shroud. There should be a minimum of 1/2" clearance between the clutch on the aux. A.C. compressor and the windshield washer tank. If installing on a 2009-2010 vehicle cut 8" from the engine end of the upper radiator hose and install it onto the new thermostat housing using hose clamp (20). If installing on 2011 or newer vehicle splice upper radiator hose where needed and install coupler (28) using clamps (20).
6. Install the air cleaner assembly. Replace the engine coolant and the windshield washer fluid. Make certain any wires or hoses rerouted during installation do not come in contact with any hot or moving parts. Run the engine to check for proper belt tracking.

DMK40SD508-6

2009-2017 Dodge Truck 2500,3500

5.7L Hemi

W/WO AC

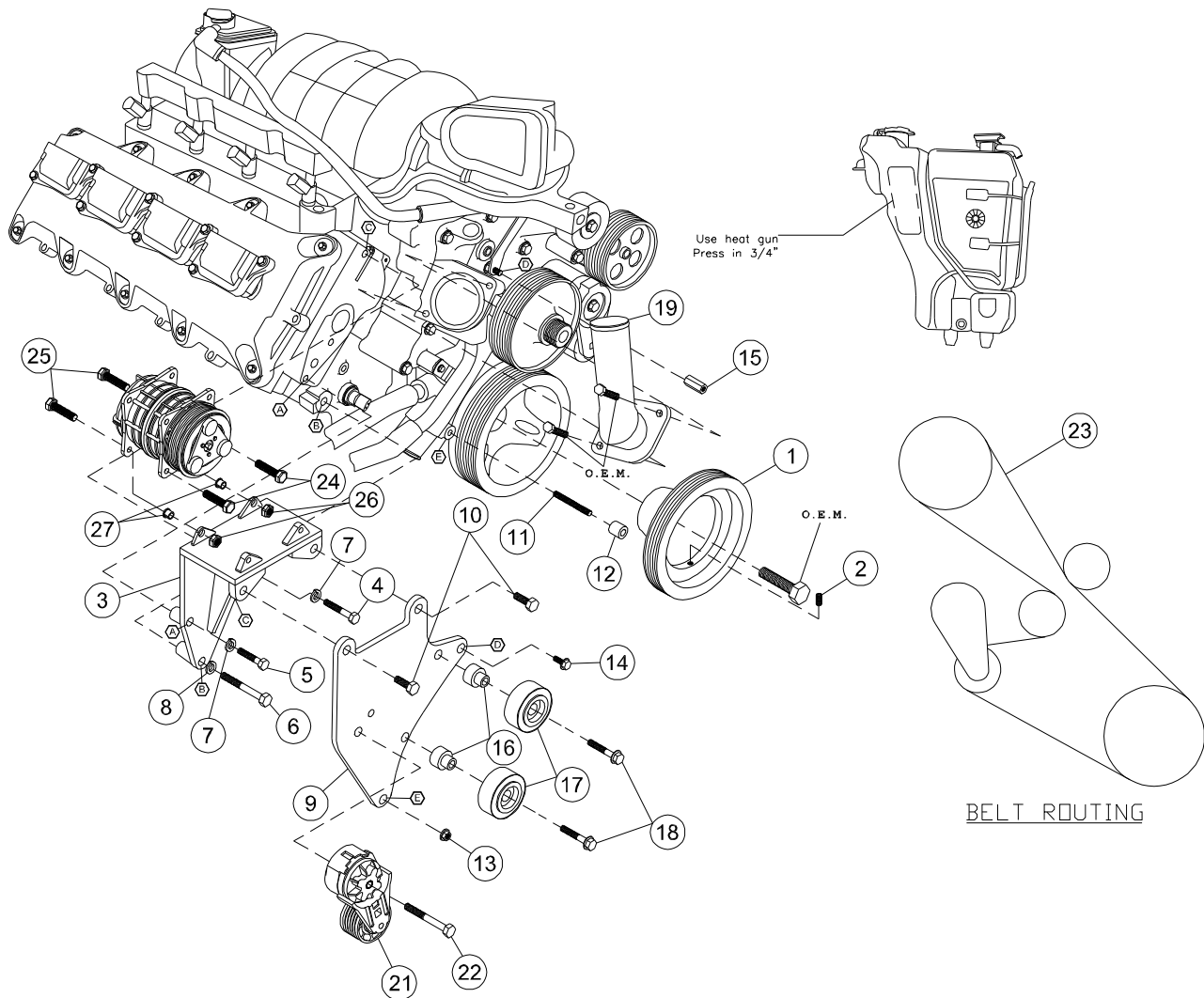

PARTS LIST

- | | |
|--------------------------------|------------------------------------|
| 1. DPC 406 (1) | 15. 8mm x 35.5mm Coupler Nut (1) |
| 2. 8mm x 25mm Set Screw (3) | 16. CMB 3867 Bushing (2) |
| 3. DMP 40SD508 (1) | 17. 89007 Dayco Idler (2) |
| 4. 8mm x 70mm (1) | 18. 10mm x 30mm Flange Bolt (2) |
| 5. 8mm x 60mm (1) | 19. DMB401 (1) |
| 6. 10mm x 70mm (1) | 20. #32 Hose Clamp (not shown) (3) |
| 7. 8mm LW (2) | 21. 89203-051 Tensioner (1) |
| 8. 10mm LW (1) | 22. 10mm x 60mm Bolt (1) |
| 9. DMB 400 (1) | 23. 5060645 Dayco Belt (1) |
| 10. 10mm x 20mm w/ .150 HD (2) | 24. 10mm x 30mm Flange (2) |
| 11. 8mm x 175mm Stud (1) | 25. 10mm x 40mm Flange (2) |
| 12. SP75-1.20 (1) | 26. 10mm Flange Nut (2) |
| 13. 8mm Flange Nut (1) | 27. 1255-0090 Slide Bushing (2) |
| 14. 8mm x 20mm Flange Bolt (1) | 28. DMB402 (1) |