



CW MILL EQUIPMENT CO., INC.
P.O. Box 246 • Sabetha, Kansas 66534
(785) 284-3454 • FAX (785) 284-3601

DMK 58SD508-I8

2011 Dodge D2500-5500

2012-2013 D2500-5500 WO Auto. Trans.

2013 Without remote mounted P.S. reservoir

6.7 Cummins Diesel W-AC

INSTALLATION NOTES

1. Drain radiator below upper radiator hose. Remove hose. Remove driver side upper shroud support. Remove belt. Remove return hose from power steering reservoir and let reservoir drain. Remove bolts from power steering pump through the holes in the pulley. Leaving pressure lines attached, set pump aside on passenger side of engine. Remove power steering pump brackets.
2. Install studs (2) in timing cover w/nuts (5). Install aux. A.C. onto bracket using bolts (13,15), slide bushings (14) and nuts (16). Install 5/8 hose(17) onto return hose using hose barb (19) and hose clamps(18). Power sheering hoses may need moved in order to gain appropriate clearance to air conditioner compressor.
3. Install aux. A.C. and bracket assembly onto studs (2) using nuts(5). Check alignment on compressor and adjust with shims if necessary. NOTE: It may be easier to install hoses and power wire before power steering pump is reinstalled. Install power steering pump onto bracket using bolts (6) and LW's (4). Hose on power steering pump will need to be rotated and bent slightly for clearance. *Note: Be careful not to kink power steering lines.* Install new belt (21) according to the belt diagram. Install idler (11) in lowest hole location possible while tensioner is retracted fully using bolt (9), FW (10), and bushing (12).
4. Install grommet (22) into shroud. Install shroud brace (9) using bolts (8), nut (5), and FW (3). Cut 3/4" off radiator side of top radiator hose and reinstall. Connect new power steering return hose (17) to power steering reservoir using hose barb (19) and hose clamps (18). Fill reservoir w/ATF Plus 4 transmission fluid. Fill radiator and overflow tank. Check for proper belt tracking and clearances.

DMK 58SD508-I8 Belts

2011 Dodge D2500-5500

2012-2013 Dodge D2500-5500 WO Auto. Trans.

2013 Without remote mounted P.S. reservoir

6.7 Cummins Diesel W-AC

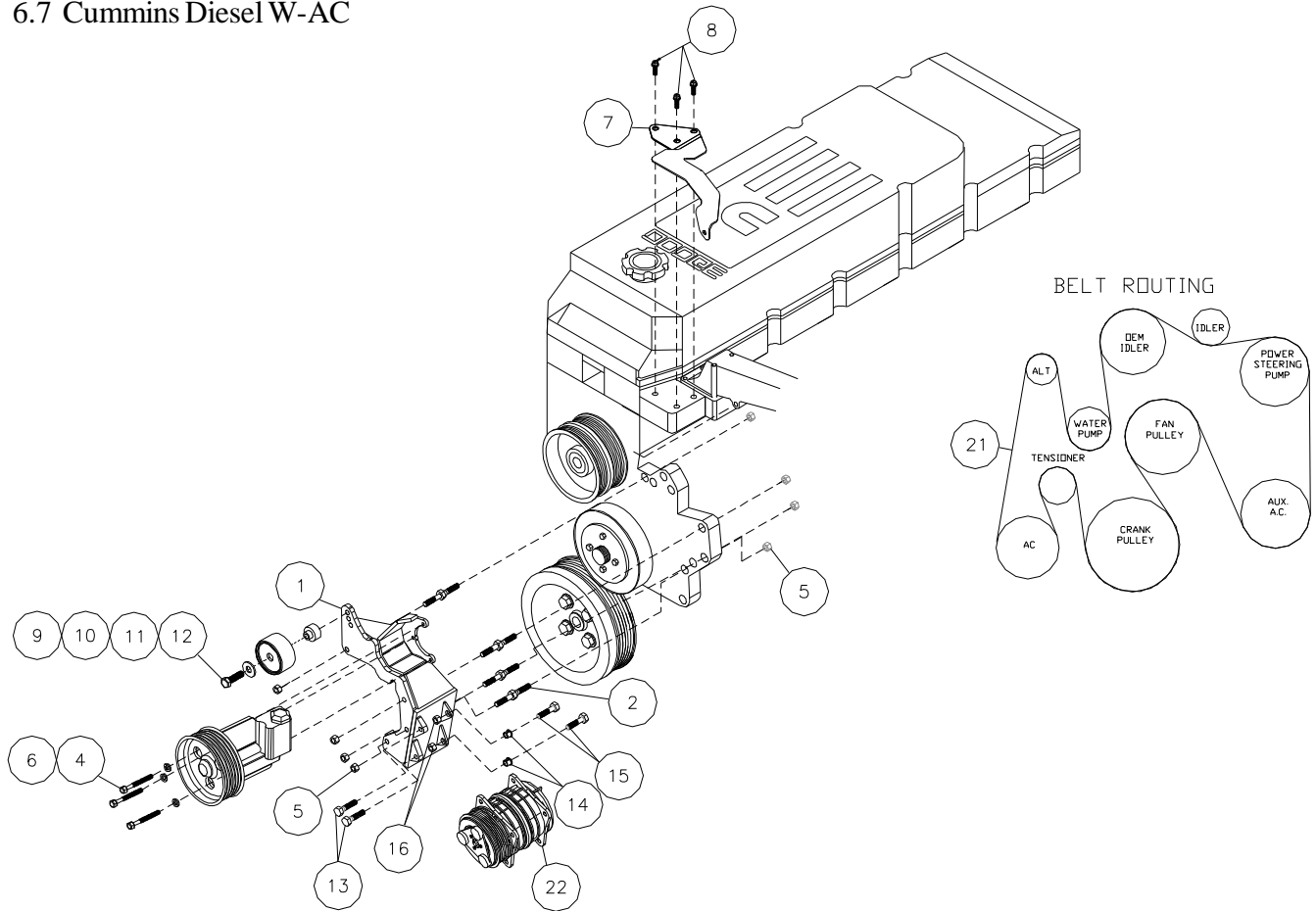

PARTS LIST

- | | | | |
|-----|-----------------------------|-----|--------------------------------|
| 1. | DMP58SD508-I8 (1) | 12. | DMB 562 (1) |
| 2. | 8mm Stud 08075-1.24 ST (4) | 13. | 10mm x 30mm Flange Bolt (2) |
| 3. | 8mm Nut (1) | 14. | 1255-0090 Slide Bushing (2) |
| 4. | 8mm LW (3) | 15. | 10mm x 40mm Flange Bolt (2) |
| 5. | 8mm Flange Nut (8) | 16. | 10mm Flange Nut (2) |
| 6. | 8mm X 80mm Bolt (3) | 17. | 14"-5/8 Oil Hose (1) |
| 7. | DMB563 (1) | 18. | #10 Hose Clamp (2) |
| 8. | 10mm X 20mm Flange Bolt (3) | 19. | 5/8 Double Ended Hose Barb (1) |
| 9. | 10mm x 45mm Bolt (1) | 20. | 15" Plastic Tie (1) |
| 10. | 3/8 FW (1) | 21. | 5081300 Belt (1) |
| 11. | 89016 Dayco (1) | | |