



CW MILL EQUIPMENT CO., INC.
P.O. Box 246 • Sabetha, Kansas 66534
(785) 284-3454 • FAX (785) 284-3601

FMK261SD508-8

2011 F-250-550

6.7L Diesel

W-WO/AC W/O Dual Alternators

INSTALLATION NOTES

1. Disconnect batteries. Remove the air cleaner from the passenger side and the charge air tube from the drivers side. Remove the P/S reservoir from the fan shroud and lay aside. It is not necessary to drain any P/S fluid. Remove the top half of the fan shroud. Unplug the fan wire and remove the fan. Fan nut has right hand threads. Remove the top two fan diffuser nuts. Remove the belt and tensioner. Remove the 5 bolts holding the fan hub to the engine and remove it from the engine compartment. Retain the bolts for use in installation.
2. Remove the four bolts from the crank pulley and install the new drive pulley(1) using bolts(2). A mild grade of lock-tite is recommended. Remove the split bushings from the OEM bracket and install them into the new bracket. Install compressor onto bracket(4) using bolts(19,20), nuts(21) and slide bushings(22). Install the main bracket(3) in place of the fan hub reusing the OEM bolts. Check alignment and install shims included with compressor hardware only if needed.
3. Install the OEM tensioner and the OEM belt back onto the engine as shown in illustration on back. Remove the idler from the OEM fan hub and remove the bolt from the idler. Install the O.E.M. idler using bolt(13), lockwasher(8), flatwasher(7) and bushing(10). Install tensioner bracket(4) onto the bracket and engine using bolts(5,6). Install idler(15) with the short bushing(11) to tensioner bracket(4) using bolt(14), lockwasher(8), and flatwasher(7). Install idler(15) with the long bushing(9) onto bracket(3) using bolt(12), lockwasher(8) and flatwasher(7). Install tensioner(16) using bolt(17). Install auxiliary A.C. compressor drive belt(23) as shown in illustration on back.
4. Replace the nuts onto the fan diffuser. It may be necessary to trim the diffuser if it hits the clutch. Replace the fan. Tighten the fan nut, then rotate the wire holder up and bolt it to bracket(4) using bolt(18). Replace the fan shroud. Replace the air cleaner and charge air tube.
5. Make certain no wires come in contact with any moving or hot parts.

FMK261SD508-8

2011 F-250-550

6.7L Diesel

W-WO/AC W/O Dual Alternators

6.7L FORD O.E.M.
BELT ROUTING

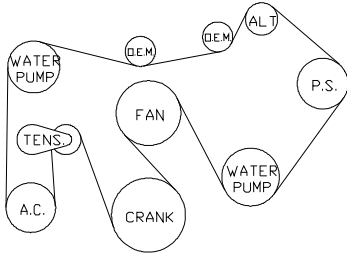

AUX. COMPRESSOR
BELT ROUTING

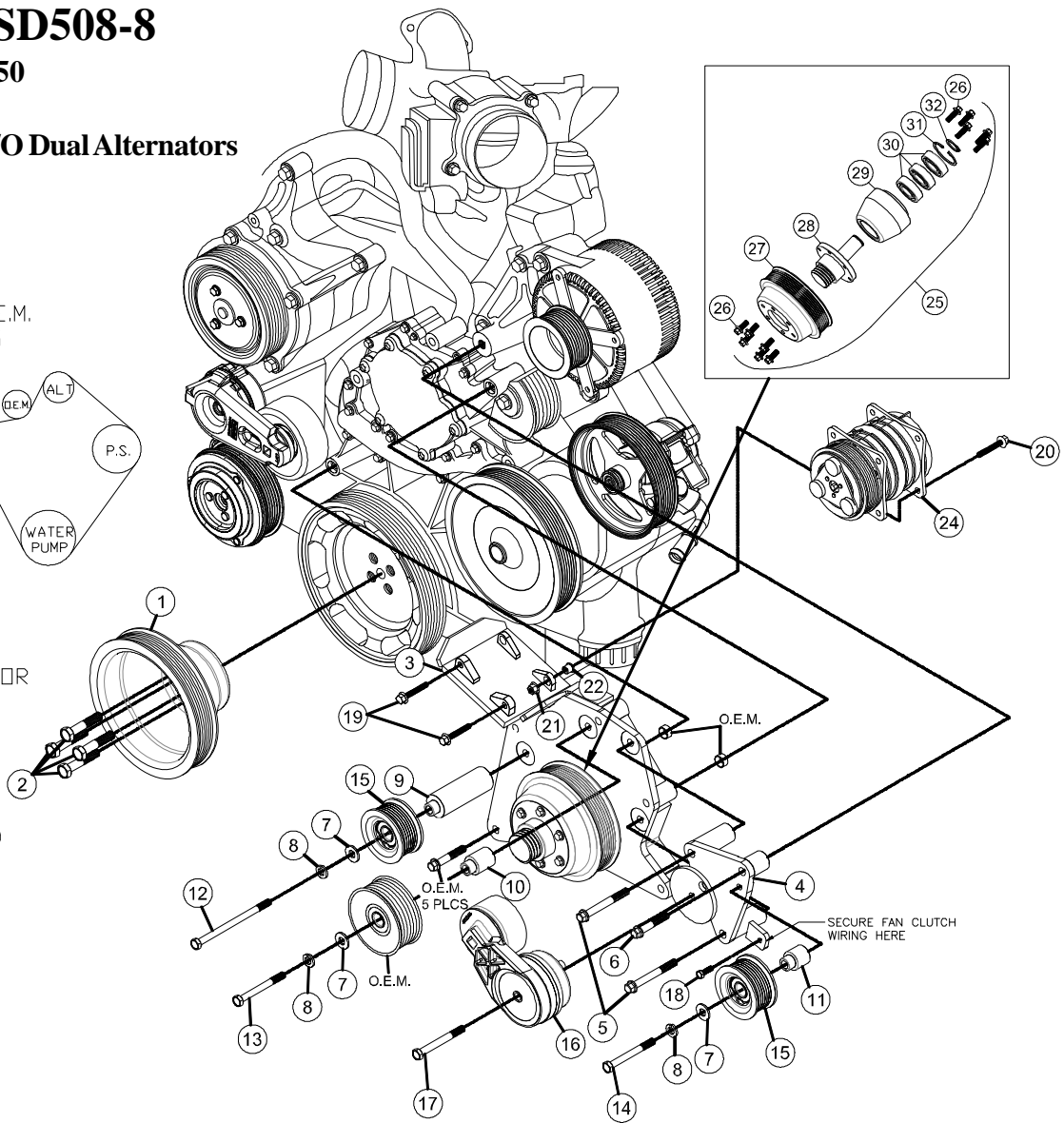
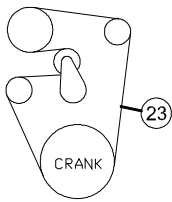

PARTS LIST

- | | |
|--|--|
| 1. FPC2618AL (1) | 18. 8mm x 12mm Flange (1) |
| 2. 12mm x 75mm 1.5 (4) | 19. 10mm x 30mm Flange (2) |
| 3. FMP261SD508-8 (1) (<i>Does not include assembly 25</i>) | 20. 10mm x 40mm Flange (2) |
| 4. FMB2610 (1) | 21. 10mm Flange Nut (2) |
| 5. 10mm x 80mm Flange (2) | 22. 1255-0090 Slide Bushing (2) |
| 6. 10mm x 50mm Flange (1) | 23. Dayco 5080715 (1) |
| 7. 3/8 Flatwasher (3) | 24. A.C. Compressor (<i>Sold Separately</i>) |
| 8. 10mm Lockwasher (3) | 25. FSK261 (1) |
| 9. FMB2617 (1) | <u>ITEM 25 INCLUDES ITEMS 26-32</u> |
| 10. FMB2616 (1) | 26. 8mm x 20mm Flange (11) |
| 11. FMB2615 (1) | 27. FPC2618-2 (1) |
| 12. 10mm x 120mm (1) | 28. FSO261 (1) |
| 13. 10mm x 60mm (1) | 29. FMB2611 (1) |
| 14. 10mm x 50mm (1) | 30. MRC205SZZ Bearing (3) |
| 15. GIPCS8 (2) | 31. HO206ST-PA Snap Ring (1) |
| 16. 89470 Dayco (1) | 32. SH98 Snap Ring (1) |
| 17. 10mm x 65mm (1) | |