

INSTALLATION NOTES

1. Disconnect the negative battery cable and drain coolant. Remove the accessory drive belt from the engine. Remove the stud at location "A" and replace it with stud (2) and shim washer (4). Torque to 35ft/lbs.. Remove the O.E.M. idler from the engine from location "B". This will be replaced by idler (10) reusing O.E.M. bolt. Remove the alternator and the alternator brace. Remove heater hose from intake manifold. Install heater hose (21) with hose clamp (23) to intake manifold. Install hose barb (22) between heater hose (21) and O.E.M. hose using hose clamp (23) and O.E.M. clamp.
2. Install bracket (1) using bolts (3) and nut (6) with lock washer (5) on stud (2) at location "A". Torque nut (6) to 35ft/lbs. and bolts (3) to 18ft/lbs.. Install alternator onto bracket (1) using O.E.M. hardware. Install braces (7,8) with O.E.M. hardware.
3. Install the O.E.M. idler that was removed in step 1 onto the engine on the driver's side at location "B" using bolt (15), lock washer (14) and flat washer (13). Install the aux. A.C. onto the bracket (1) with bolts (16,17), slide bushing (19), and nut (18). Torque to 30ft/lbs.. Install idler (10) using spacer (9), washer (11) and bolt (12) onto the main bracket (1) in the lowest hole possible to still be able to install the belt (20) and torque to 30ft/lbs..
4. Install the new drive belt (20) according to the belt diagram. It is easiest to install the belt over idler (10) located between the alternator and the aux. A.C. compressor last. Replace the coolant. Connect the battery cable. Run the engine and make certain the belt tracks properly, and is in the grooves on all the pulleys.

CAUTION: Check all engine compartment hoses and wiring to insure they are not kinked, touching any high temperature item, or do not interfere with any linkage components.

FMK46SD508-I6

2006-17 Ford E-250-550

5.4L, 6.8L, Triton

W-AC

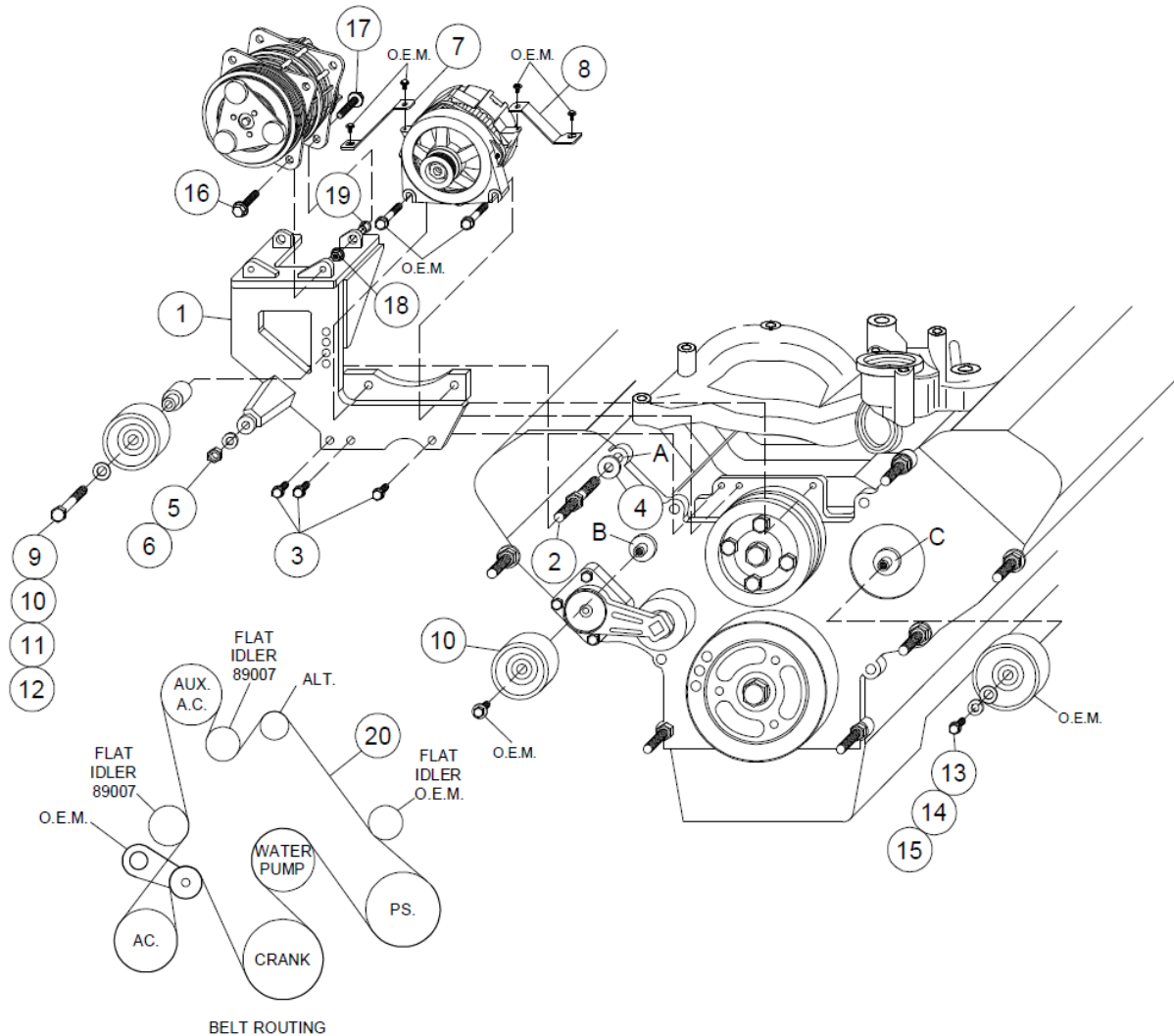

PARTS LIST

- | | |
|--------------------------|-------------------------------------|
| 1. FMP46SD508-I6 (1) | 13. 5/16 FW (1) |
| 2. 10107 1.5 ST (1) | 14. 8mm FW (1) |
| 3. 8mm x 25mm Flange (3) | 15. 8mm x 20mm (1) |
| 4. .80 Shim Washer (1) | 16. 10mm x 30mm Flange (2) |
| 5. 10mm LW (1) | 17. 10mm x 40mm Flange (2) |
| 6. 10mm Nut (1) | 18. 10mm Flange Nut (2) |
| 7. FMB462SD508-I6 (1) | 19. 1255-0090 Slide Bushing (2) |
| 8. FMB463SD508-I6 (1) | 20. 5061300 Dayco Belt (1) |
| 9. FMB461SD508-I6 (1) | <u>ITEMS 21-23 NOT SHOWN</u> |
| 10. 89007 Dayco (2) | 21. 3/4" 90 deg. elbow (1) |
| 11. 3/8 FW (1) | 22. 3/4 Double Ended Hose Barb (1) |
| 12. 10mm x 75mm (1) | 23. Dayco #12 Hose Clamp (2) |