

INSTALLATION NOTES

1. Disconnect negative battery cable. Remove the O.E.M. belt. Remove the upper right hand bolt from the power steering reservoir, the upper alternator bolt and the right hand bolt from the tensioner. Remove the wiring harness retainer from the timing cover.
2. Install main bracket (1) using bolts (2,4,5) and lock washers (3,6). Install idlers (8) onto bracket (1) using bolts (9) and spacers (7).
3. Install auxiliary A.C. compressor onto the main bracket (1) with bolts (9,11), nuts (12) and slide bushings (13). Install new belt (10) according to the belt diagram on the back. Belt is 7 grooves and will run on the front 7 grooves of most 8 groove compressors. Shim should not be needed. Check alignment with a good quality straight edge.
4. Connect battery. Run the engine and check for proper belt tracking. Belt alignment is the installer's responsibility.

NOTE: Check all engine component hoses and electrical wiring that may have been disturbed or rerouted during kit installation to be sure that hoses are not kinked, that they do not touch any high temperature items, and that they do not interfere with any linkage components.

NMK50SD508-I7

2011-2016 NISSAN "NV"

5.6L V8 GAS

W/ AC

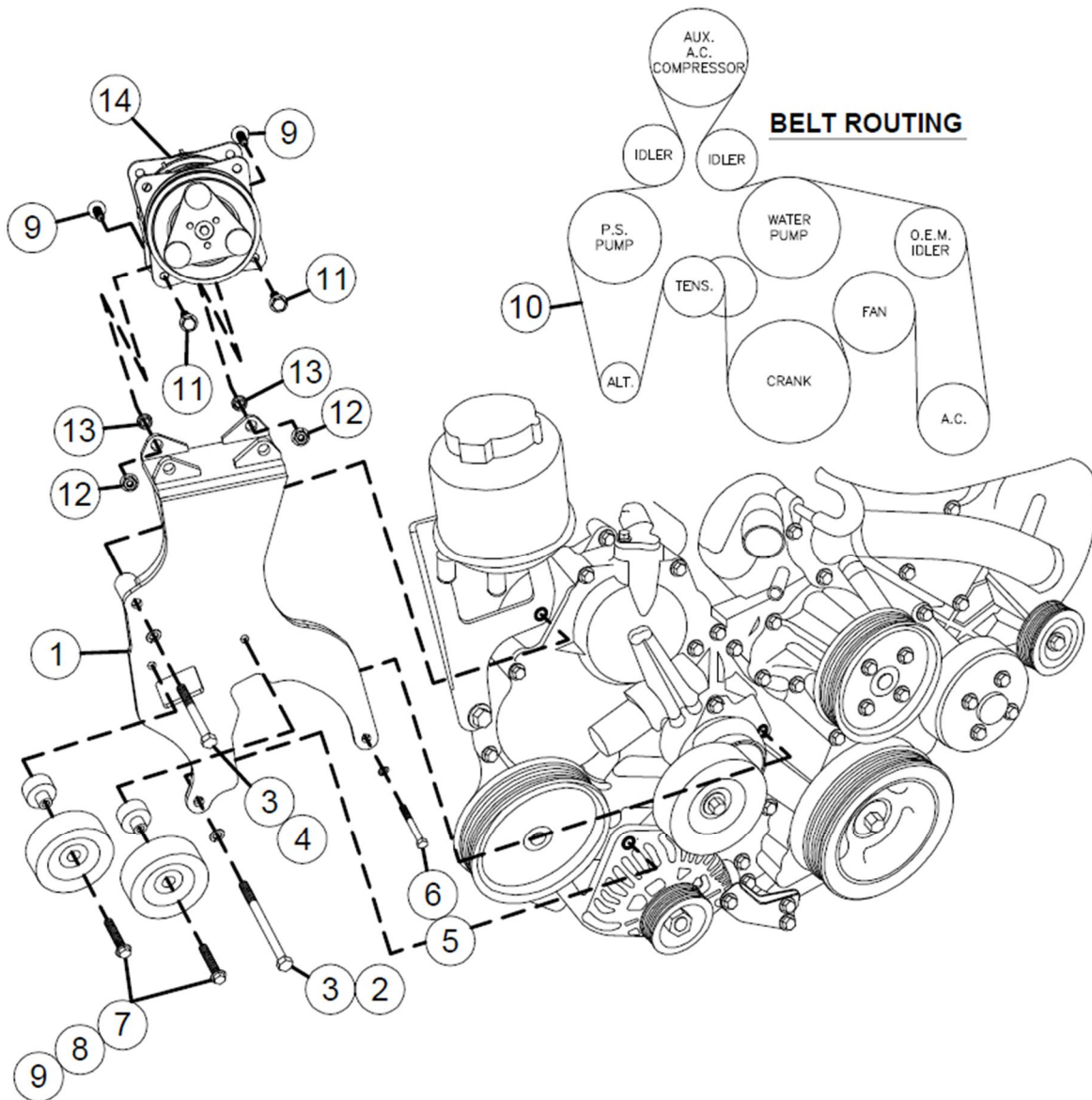

PARTS LIST

- | | |
|--------------------------|--|
| 1. NMP50SD508-I7 (1) | 8. Dayco 89016 (2) |
| 2. 10mm x 130mm 1.25 (1) | 9. 10mm x 40mm Flange Bolt (4) |
| 3. 10mm LW (2) | 10. Dayco 5071254 Belt (1) |
| 4. 10mm x 75mm 1.5 (1) | 11. 10mm x 30mm Flange Bolt (2) |
| 5. 8mm x 65mm 1.25 (1) | 12. 10mm Flange Nut (2) |
| 6. 8mm LW (1) | 13. 1255-0090 Slide Bushing (2) |
| 7. SMB373 (2) | 14. Auxiliary A.C. Compressor (<i>Sold Separately</i>) |